

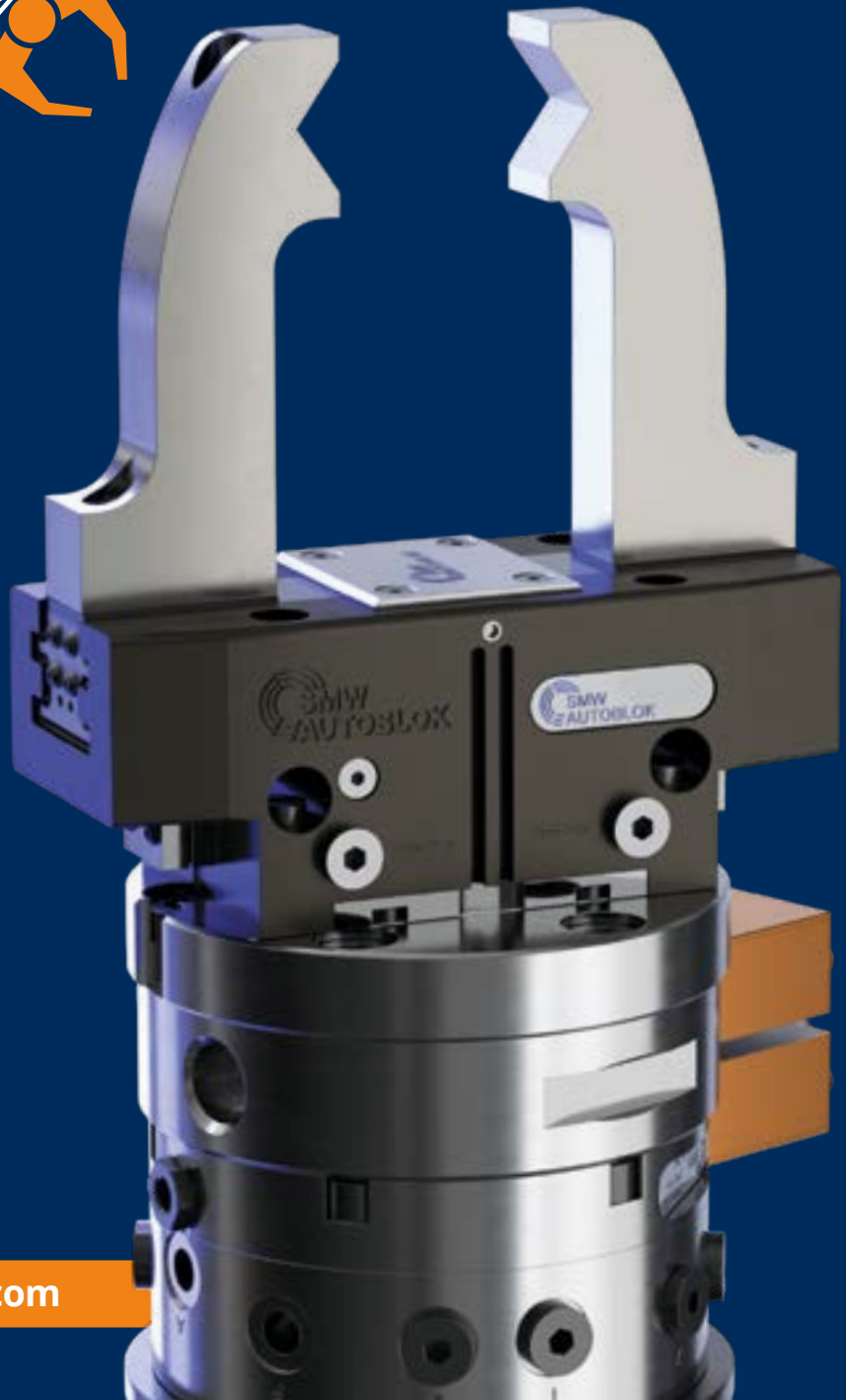

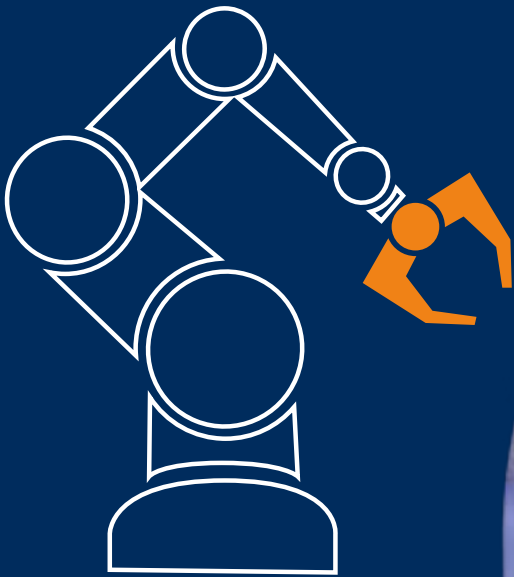







AUTOMATION CATALOGUE | 2024



AUTOMATION

www.smwautoblok.com

AUTOMATION

1	APS Features and Accessories	5	
2	MODULE HEIGHT EXTENSION APS and CLAMPING UNIT APS Benefits and products features	21	
3	ROTARY PLATE Quick change system	43	
4	AT-PM Quick chucks change system	89	
5	ONE APS PALLET and MULTIPLE CLAMPING PALLET Pallet possible configurations to APS	101	
6	GRIPPERS With 2 and 3 jaws	125	
7	PRS Quick grippers change	201	
8	MECHATRONIC Grippers and accessories	215	
9	STORAGE and LOADING STATION Automation Accessories	227	

1

APS FEATURES and accessories

6

APS

Features for sizes and models.
Ø 100-140-160-190-250

15

CLAMPING PINS

Positioning and clamping of the devices and/or of the workpiece are achieved through the clamping pins.

20

KEYS

keys kit for all APS models.

20

COVERS

MAGNET PROTECTION COVERS for all APS models.

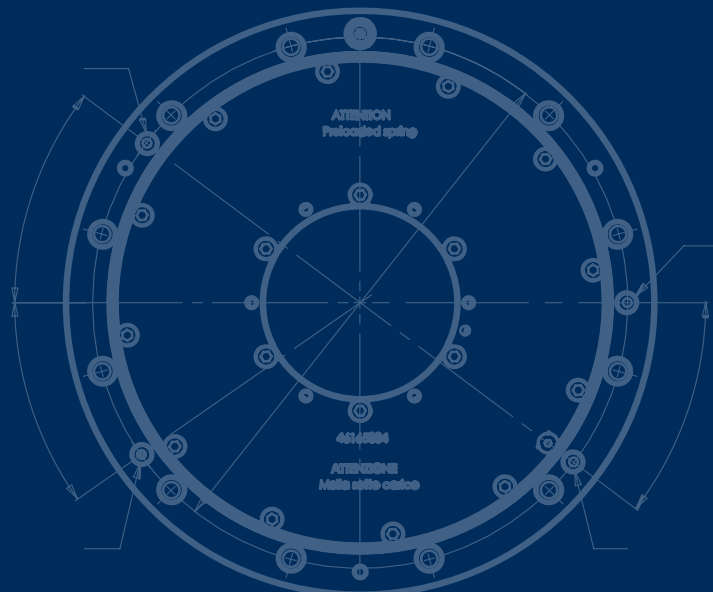

APS

ZERO POINT clamping system

CUSTOMER BENEFITS

- Fully sealed (proofline)
- Highest stiffness by means of 3 clamping slides
- Low installation height due to the compact design
- Highest process reliability and repeat accuracy < 0.005 mm
- Modular construction kit system: Existing clamping systems can be modified very easy
- Significantly reduced costs due to reduced set-up times



Machine tool stop
Production



MACHINE SET-UP COSTS

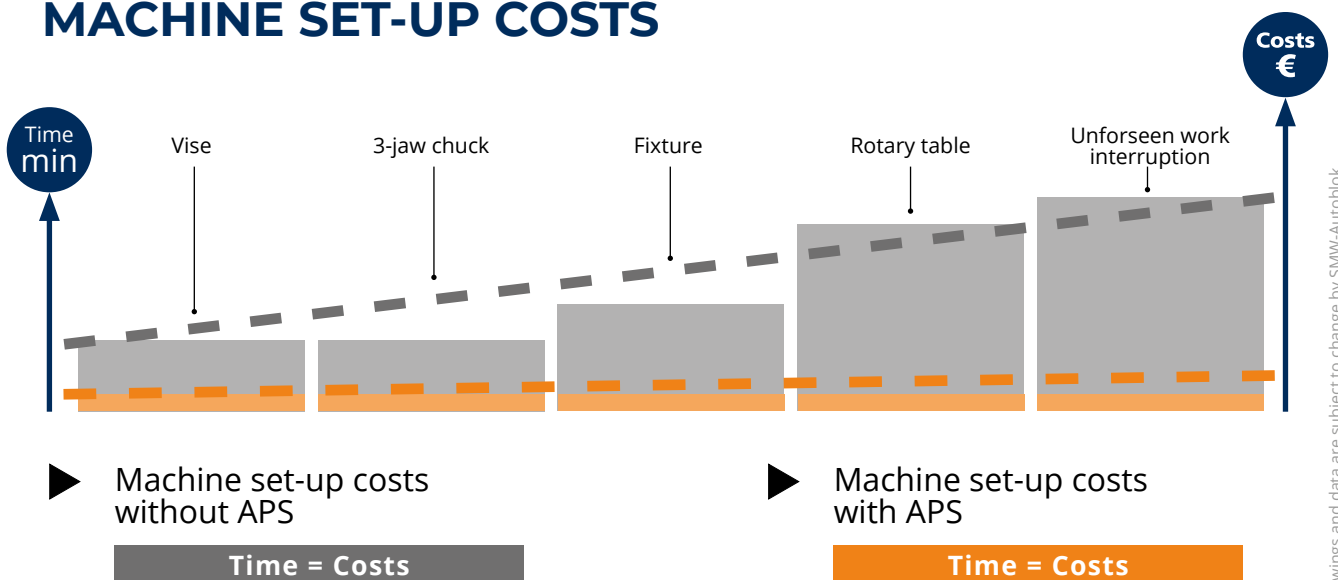

Drawings and data are subject to change by SMW-Autoblok.

APS features

Ø 100-140-160-190-250

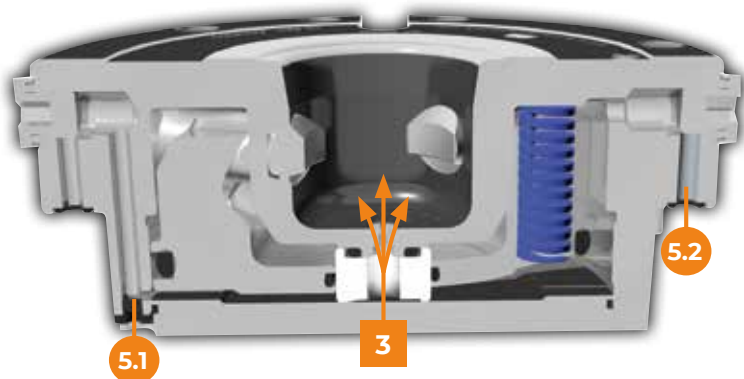

5. TURBO FUNCTION

5.1 UNLOCKING FUNCTION

at 6 bar.

5.2 TURBO FUNCTION

The **TURBO** function is always integrated in **APS** modules. **TURBO** is the function by means of which the compressed air increases the clamping force applied by the springs until reaching the "PULL DOWN" clamping force

1. MAXIMUM RIGIDITY

Jaws with double inclined plane which generates the "PULL DOWN" effect and piston with integral inclined planes.

2. MAXIMUM ACCURACY

Maximum accuracy of the tapered coupling between the pin and the module.

3. AIR SENSING

It is possible to monitor the clamping device's supporting surface through the air sensing.

4. STROKE CONTROL SYSTEM

The **SC system** is ideal for automated applications with robot loading and unloading of the pallets. The APS locking and unlocking is monitored by air pressure.

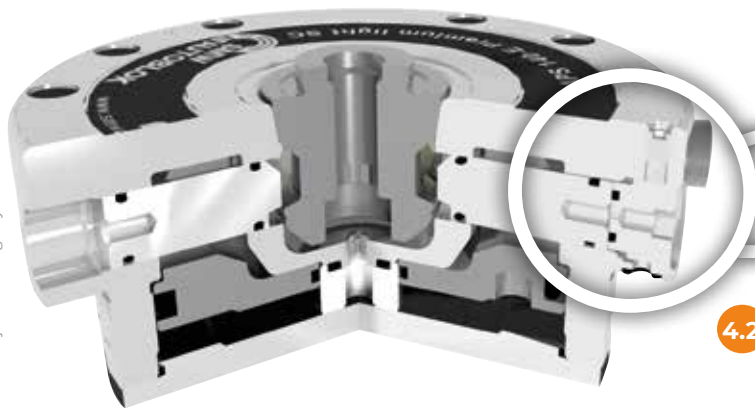

ATTENTION: the pneumatic system of the pressure switch must signal the alarm condition and must prevent the pallet exchange on the APS or any robot operation when the inlet pressure is less than 6 bar.

6. CLAMPING SYSTEM WITH 3 JAWS at 120°

APS is the only one ZERO POINT clamping system with 3 jaws at 120° and thanks to special treatments of the clamping jaws further improves its durability.

7. AIR CLEANING

The built-in air cleaning function ensures that the clamping system's supporting surface remains clean and free of chips while the modules are being opened.

4.1 LOCKING POSITION

The air enters from the lower side inlet the hole and exits out from the hole **w** = pressure drop in the line and the machine receives a "APS locked" confirmation.

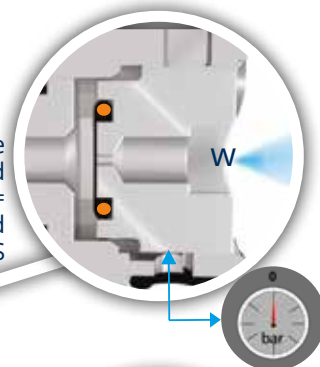

4.2 UNLOCKING POSITION

The air enters from the lower side inlet and it can't escape from the hole **w** = no pressure drop in the line and the machine receives a "APS unlocked" confirmation.

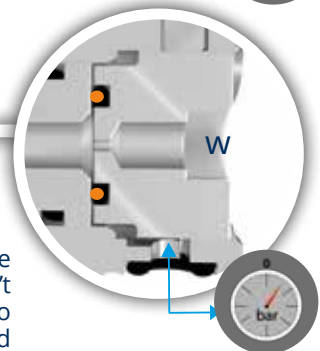

APS 100 E BASIC - ID.N. 460007 for external mounting



Zero Point Clamping Module

Technical features

- 2 Clamping slides
- TURBO function **T** to increase the clamping force

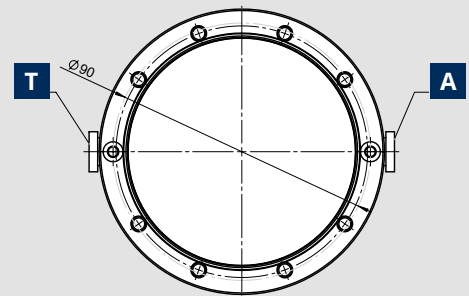
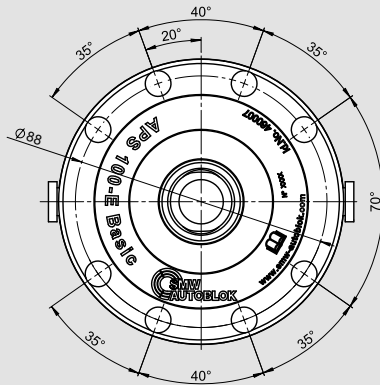
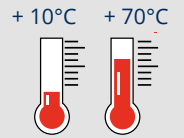
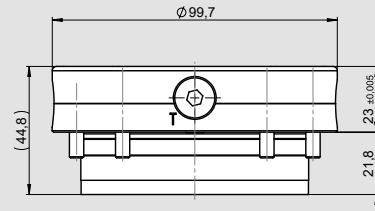
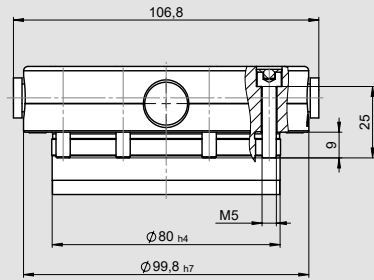

A = Open

SEALS KIT ID.N. 20590054

ID.No.	Pull down force	Holding force (*)	Unlocking pressure	Repeatability	Weight
460007	4 / 15**kN	13(M6)** 25(M8) kN	6 bar	< 0,005 mm	1,9 Kg

APS 100 E PREMIUM - ID.N. 460005 for external mounting



Zero Point Clamping Module

Technical features

- 2 Clamping slides
- TURBO function **T** to increase the clamping force
- Anti-rotation key seat
- Air sensing **P**
- Air cleaning

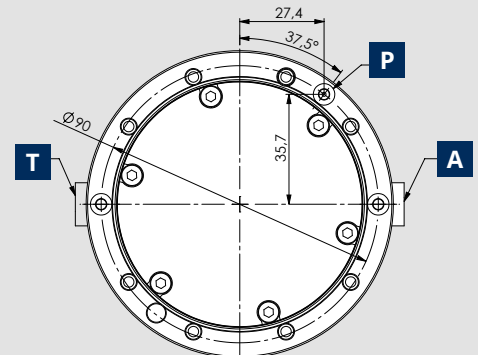
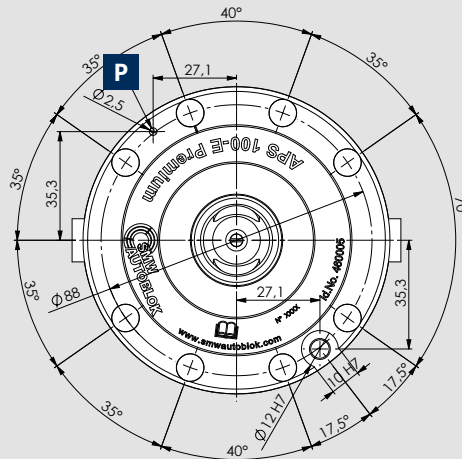
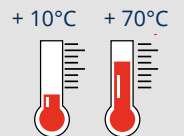
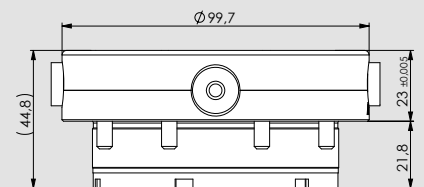
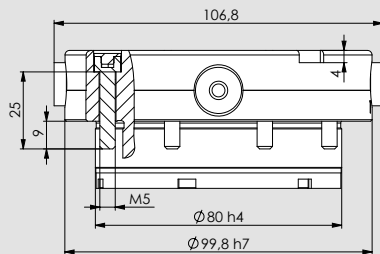

A = Open

SEALS KIT ID.N. 20590054

ID.No.	Pull down force	Holding force (*)	Unlocking pressure	Repeatability	Weight
460005	4 / 15**kN	13(M6)** 25(M8) kN	6 bar	< 0,005 mm	1,9 Kg

(*) with screws DIN EN ISO 4762 - 12.9 / (**) with "turbo effect" / (***) screws EN-ISO10642

APS 140 E BASIC - ID.N. 460001 for external mounting



Zero Point Clamping Module

Technical features

- 2 Clamping slides
- TURBO function **T** to increase the clamping force

A = Open

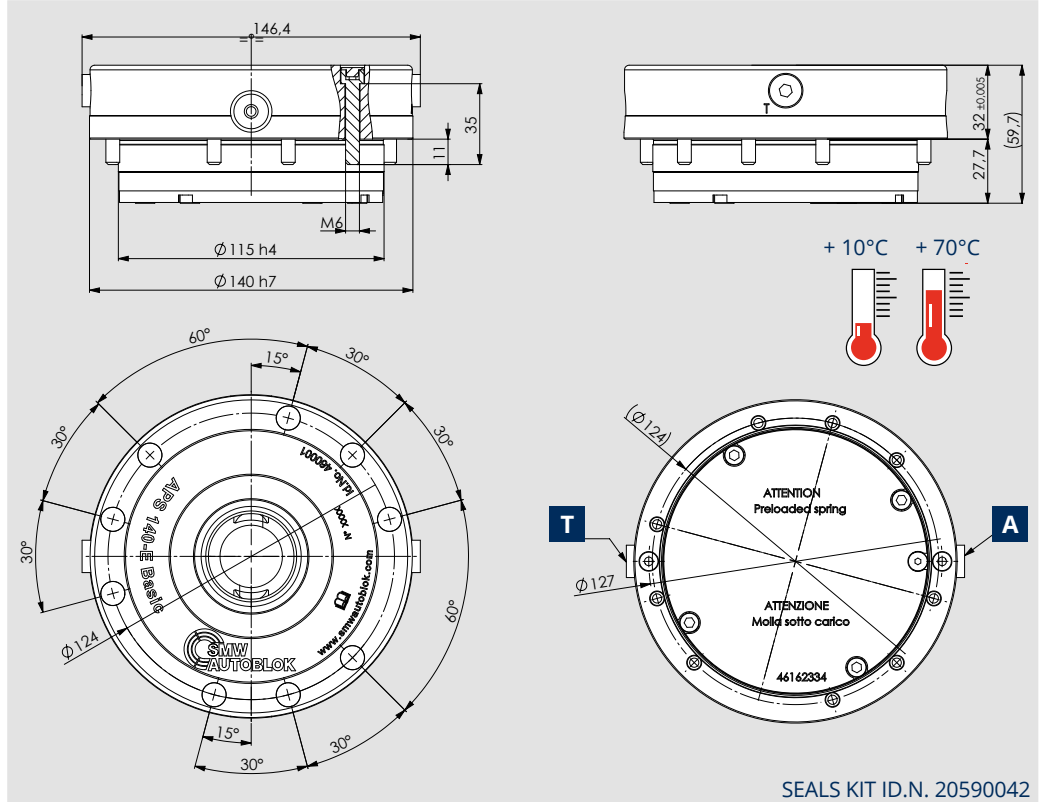

ID.No.	Pull down force	Holding force (*)	Unlocking pressure	Repeatability	Weight
460001	7,5 / 26** kN	35(M10) 50(M12) 75(M16) kN	6 bar	< 0,005 mm	4,5 Kg

APS 140 E PREMIUM LIGHT - ID.N. 460003 for external mounting



Zero Point Clamping Module

Technical features

- 3 Clamping slides
- TURBO function **T** to increase the clamping force
- Air cleaning

A = Open

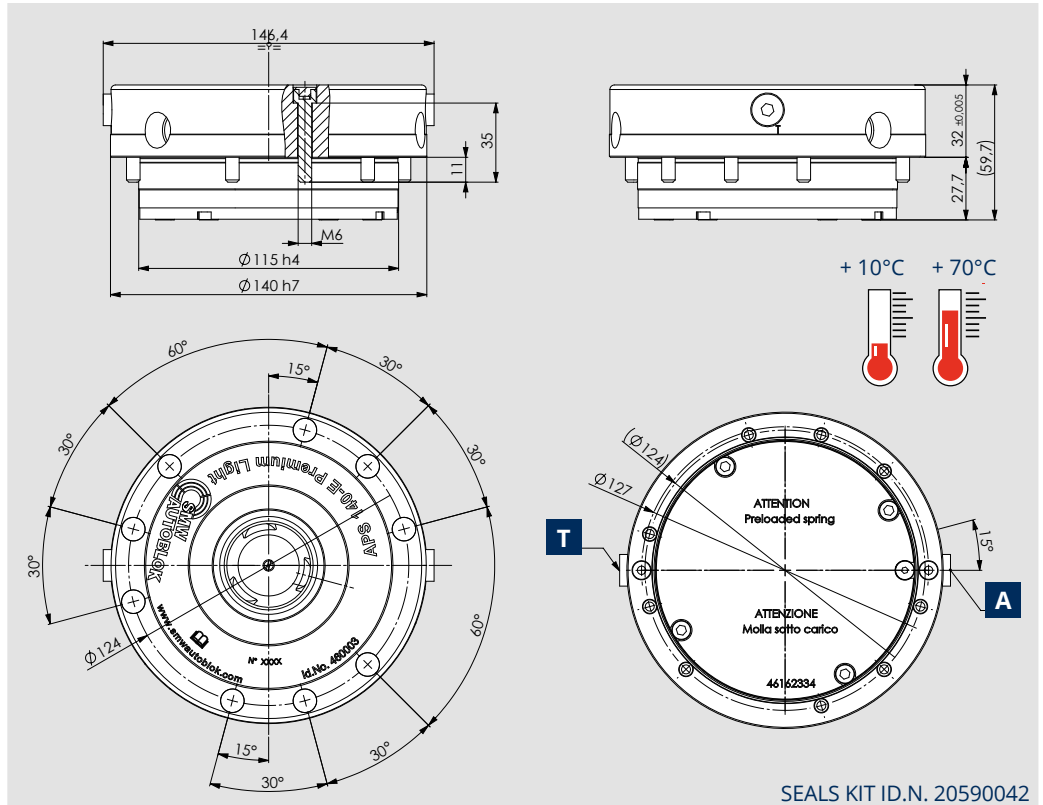

ID.No.	Pull down force	Holding force (*)	Unlocking pressure	Repeatability	Weight
460003	7,5 / 26**kN	35(M10) 50(M12) 75(M16) kN	6 bar	< 0,005 mm	4,5 Kg

(*) with screws DIN EN ISO 4762 - 12.9 / (**) with "turbo effect"

APS 140 E PREMIUM LIGHT SC - ID.N. 46162540 with pneumatic stroke control



Zero Point Clamping Module

Technical features

- 3 Clamping slides
- TURBO function **T** to increase the clamping force
- Pneumatic stroke control **SC**
- Air sensing **P**
- Air cleaning

A = Open

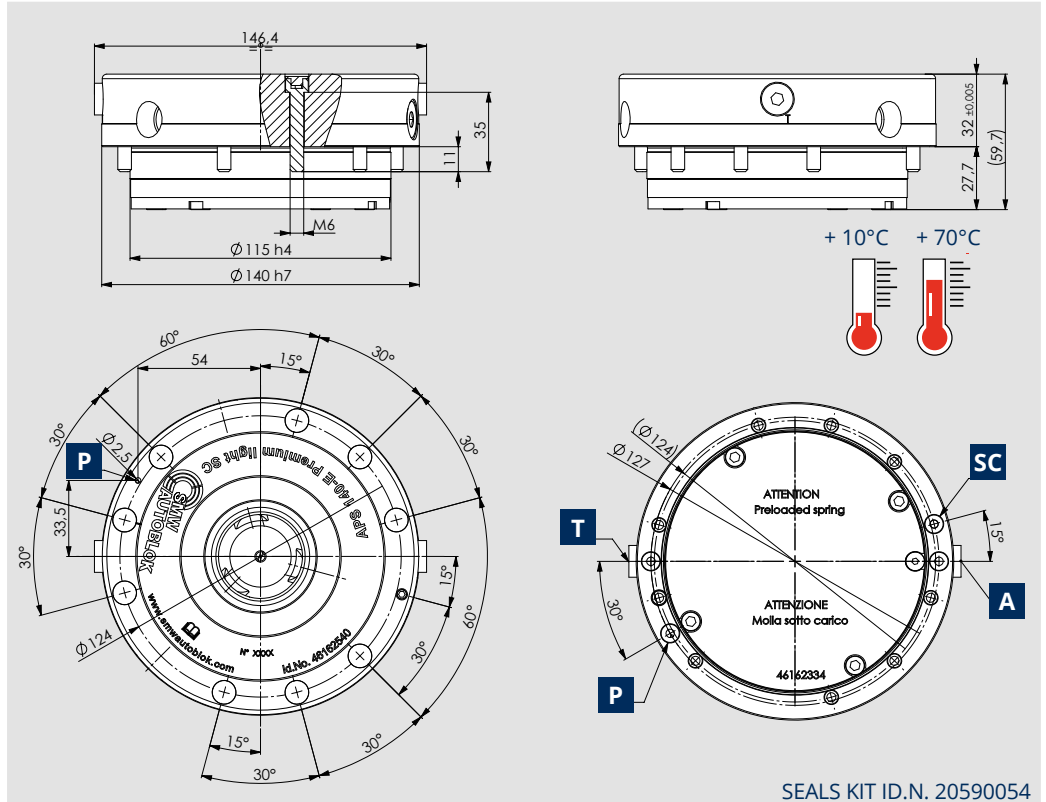

SEALS KIT ID.N. 20590054

ID.No.	Pull down force	Holding force (*)	Unlocking pressure	Repeatability	Weight
46162540	7,5 / 26** kN	35(M10) 50(M12) 75(M16) kN	6 bar	< 0,005 mm	4,5 Kg

APS 140 E PREMIUM SC - ID.N. 460002 for external mounting



Zero Point Clamping Module

Technical features

- 3 Clamping slides
- TURBO function **T** to increase the clamping force
- Pneumatic stroke control **SC**
- Air sensing **P**
- Air cleaning
- Anti-rotation key seat

A = Open

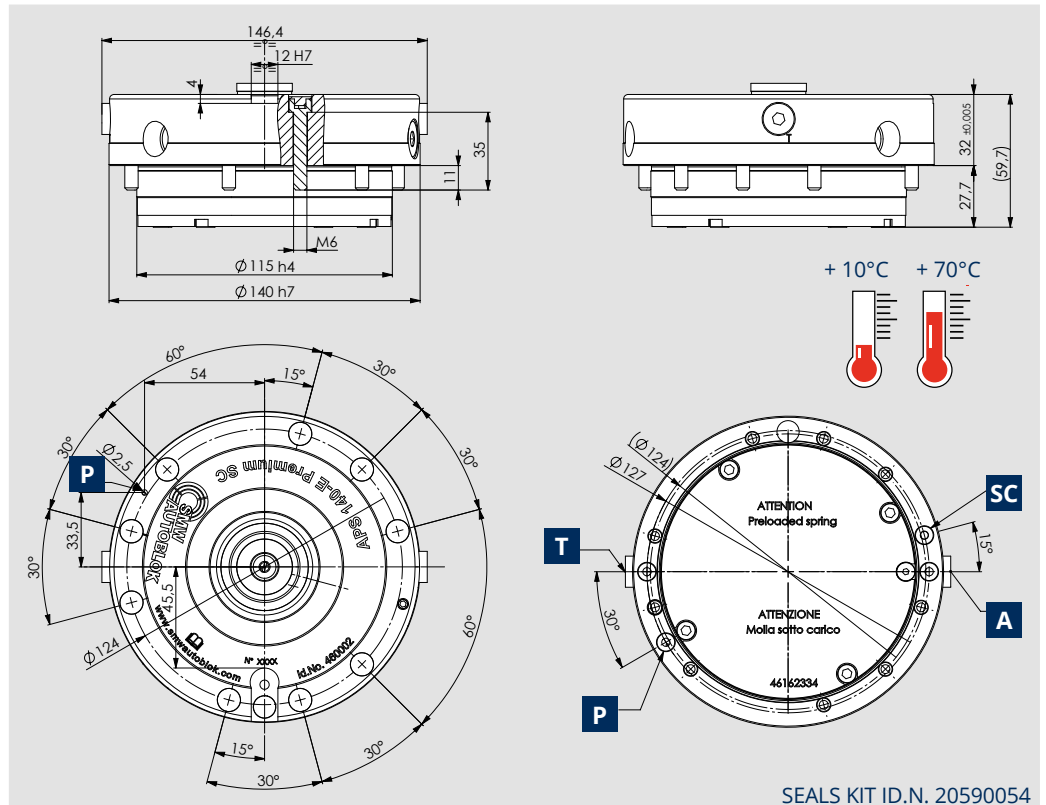

SEALS KIT ID.N. 20590054

ID.No.	Pull down force	Holding force (*)	Unlocking pressure	Repeatability	Weight
460002	7,5 / 26** kN	35(M10) 50(M12) 75(M16) kN	6 bar	< 0,005 mm	4,5 Kg

(*) with screws DIN EN ISO 4762 - 12.9 / (**) with "turbo effect"

APS 140 I PREMIUM LIGHT - ID.N. 46162480 for built-in mounting



Zero Point Clamping Module

Technical features

- 3 Clamping slides
- TURBO function **T** to increase the clamping force
- Air cleaning

A = Open

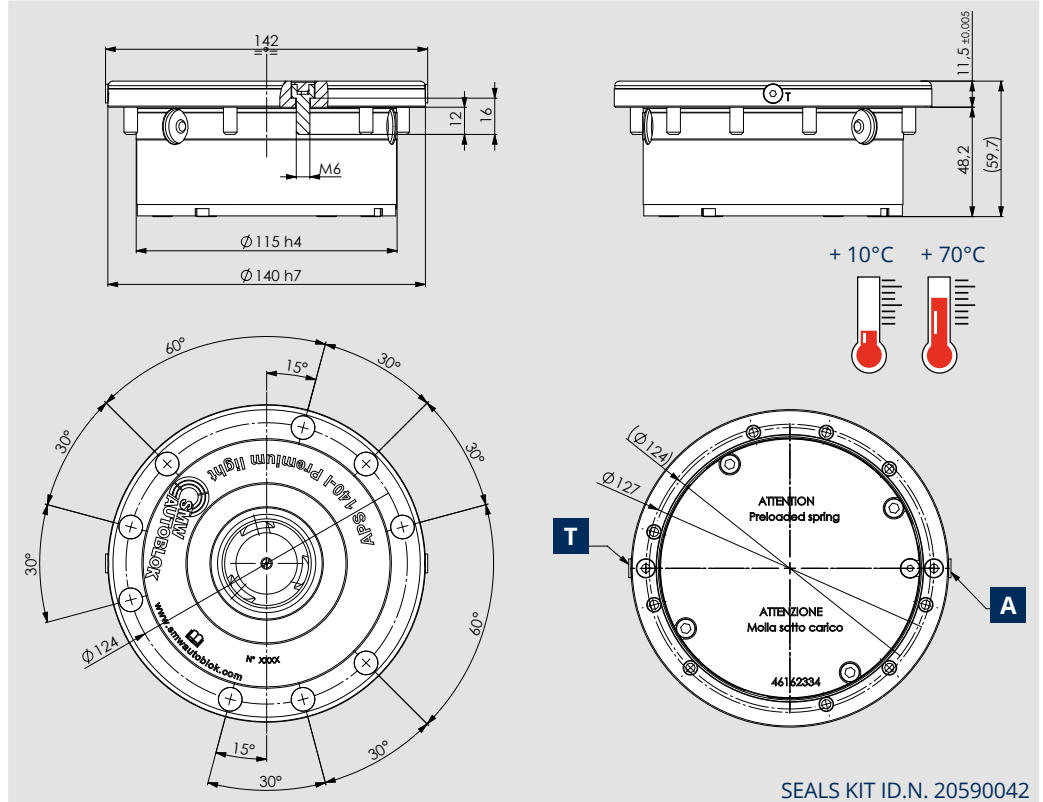

ID.No.	Pull down force	Holding force (*)	Unlocking pressure	Repeatability	Weight
46162480	7,5 / 26**kN	35(M10) 50(M12) 75(M16) kN	6 bar	<0,005mm	4,5 kg

APS 140 E Ve SC - ID.N. 46165500 NSE plus 138 interchangeable



Zero Point Clamping Module

Technical features

- 3 Clamping slides
- TURBO function **T** to increase the clamping force
- Pneumatic stroke control **SC**
- Air cleaning

A = Open

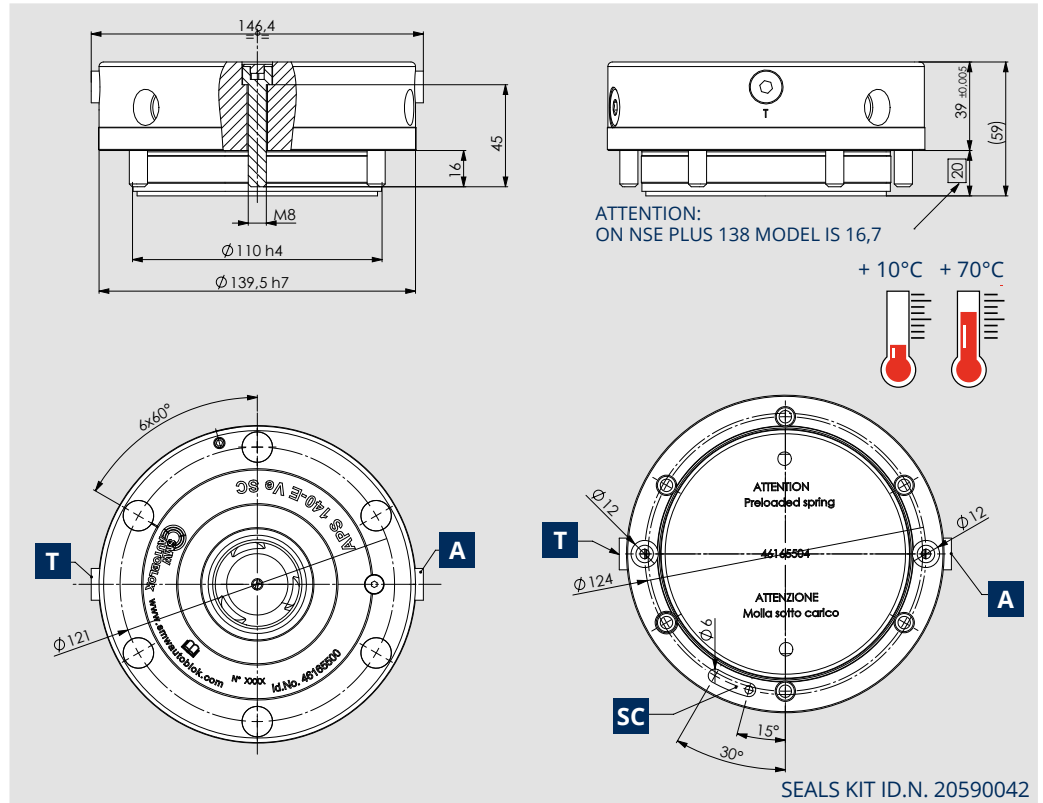

ID.No.	Pull down force	Holding force (*)	Unlocking pressure	Repeatability	Weight
46165500	7,5 / 26** kN	35(M10) 50(M12) 75(M16) kN	6 bar	< 0,005 mm	4,8 Kg

(*) with screws DIN EN ISO 4762 - 12.9 / (**) with "turbo effect"

APS 160 E PREMIUM LIGHT SC - ID.N. 46165700 for external mounting



Zero Point Clamping Module

Technical features

- 3 Clamping slides
- TURBO function **T** to increase the clamping force
- Air sensing **P**
- Pneumatic stroke control **SC**

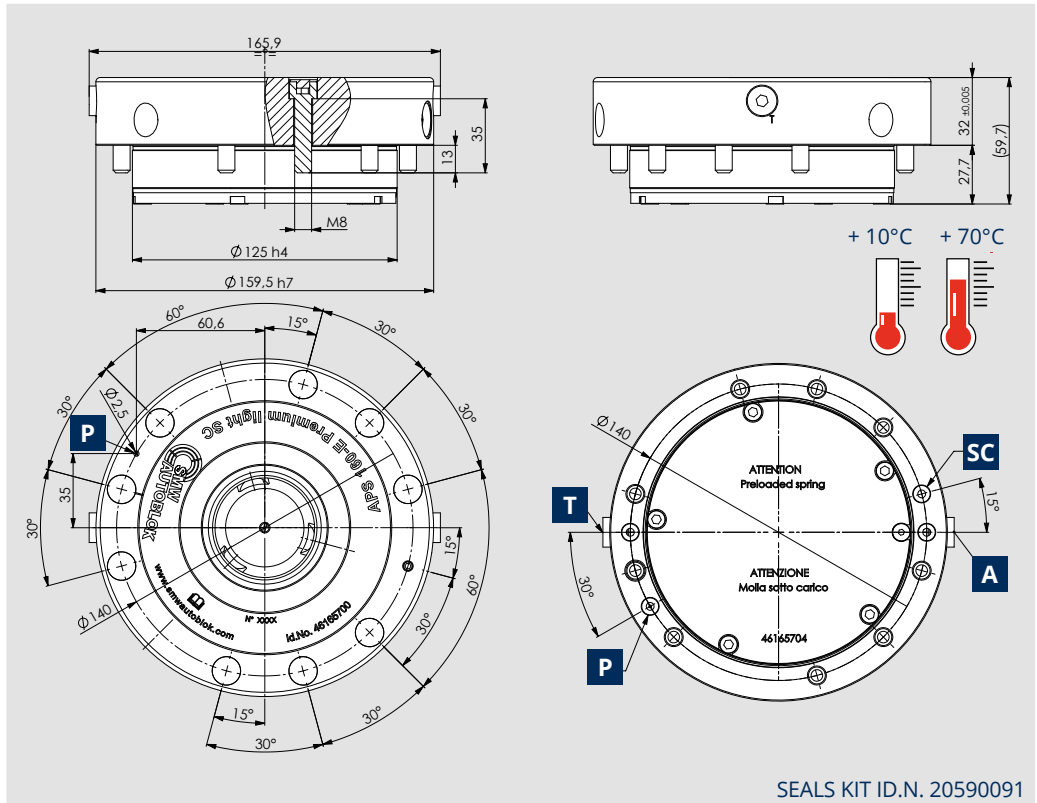

A = Open

ID.No.	Pull down force	Holding force (*)	Unlocking pressure	Repeatability	Weight
46165700	9 / 30**kN	50(M12) 75(M16) kN	6 bar	<0,005mm	5,9 Kg

APS 160 E PREMIUM SC-6S - ID.N. 46165750 prepared for maximum 6 couplers



Zero Point Clamping Module

Technical features

- 3 Clamping slides
- TURBO function **T** to increase the clamping force
- Anti-rotation key seat
- Air sensing **P**
- Pneumatic stroke control **SC**
- n.4 seats **B C D E** prepared to mount pneumatics/hydraulics couplers (71718106)
- n.2 seats **F G** prepared to mount pneumatic couplers (71483010)
- Air cleaning

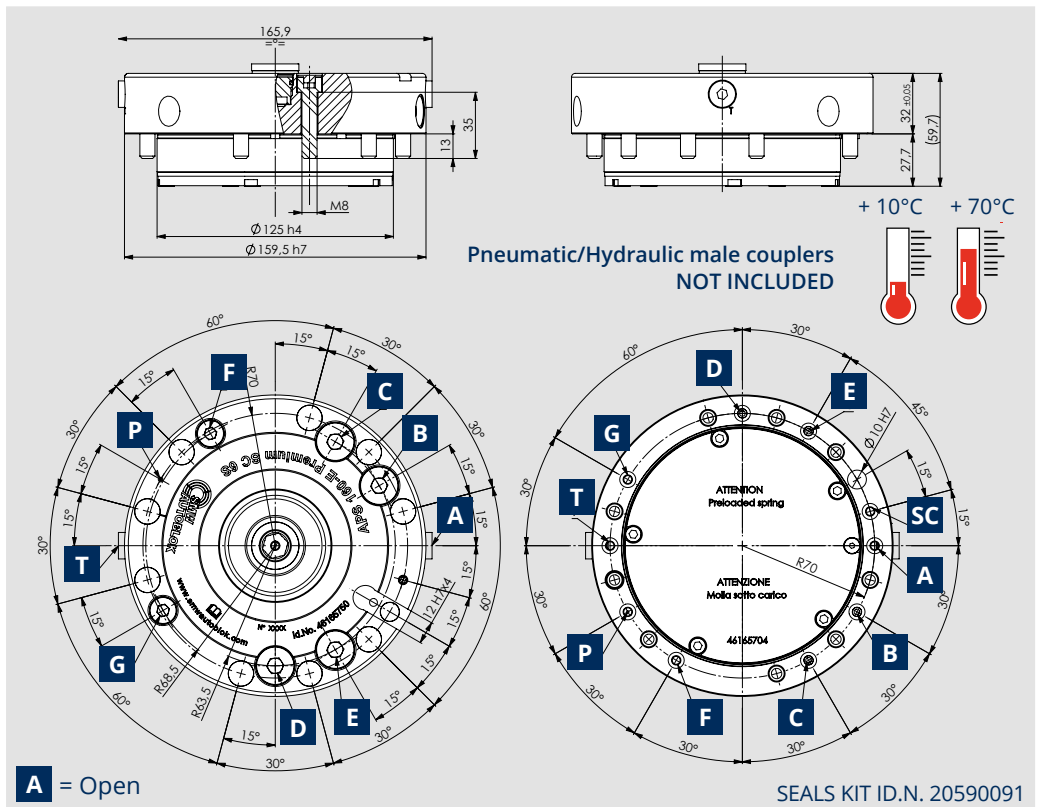

A = Open

ID.No.	Pull down force	Holding force (*)	Unlocking pressure	Repeatability	Weight
46165750	9 / 30** kN	50(M12) 75(M16) kN	6 bar	< 0,005 mm	5,9 Kg

(*) with screws DIN EN ISO 4762 - 12.9 / (**) with "turbo effect"

APS 190 E PREMIUM SC - ID.N. 46165640 with pneumatic stroke control



Zero Point Clamping Module

Technical features

- 3 Clamping slides
- TURBO function **T** to increase the clamping force
- Anti-rotation key seat
- Air sensing **P**
- Pneumatic stroke control **SC**

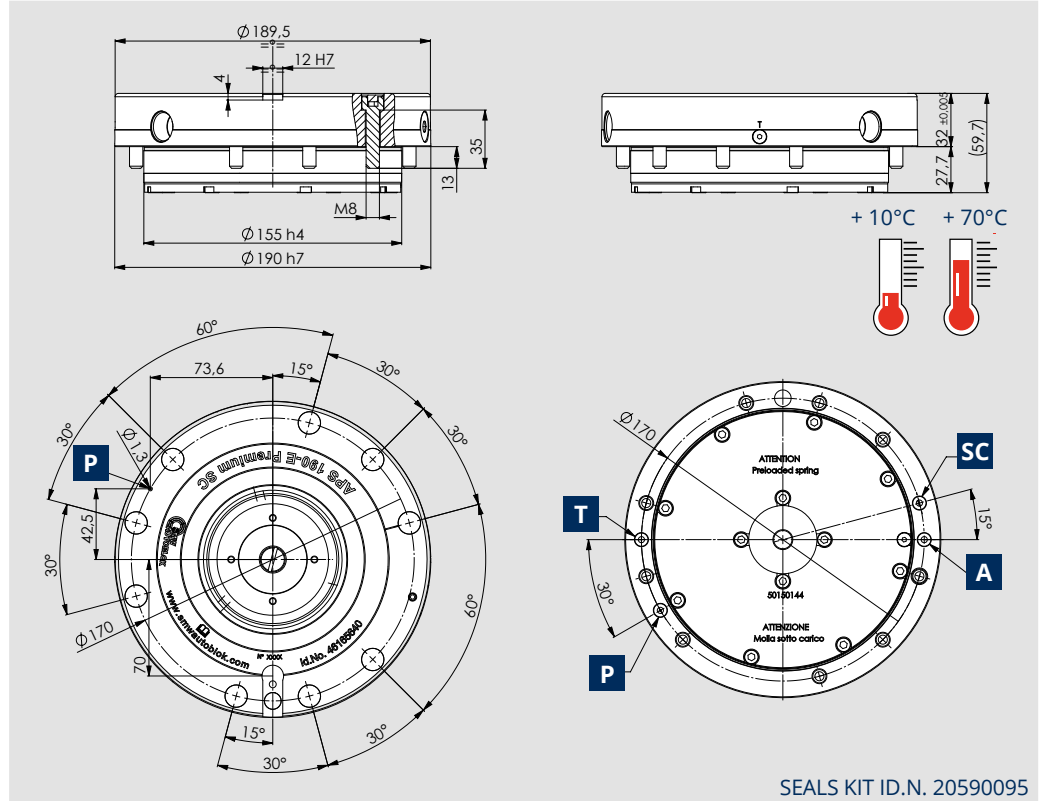

A = Open

ID.No.	Pull down force	Holding force (*)	Unlocking pressure	Repeatability	Weight
46165640	13,5 / 45** kN	50(M12) 75(M16) 80(6xM6) 150(6xM8) kN	6 bar	< 0,005 mm	6,9 Kg

(*) with screws DIN EN ISO 4762 - 12.9 / (**) with "turbo effect"

APS 190 E PREMIUM SC-6S - ID.N. 46162650 prepared for maximum 6 couplers

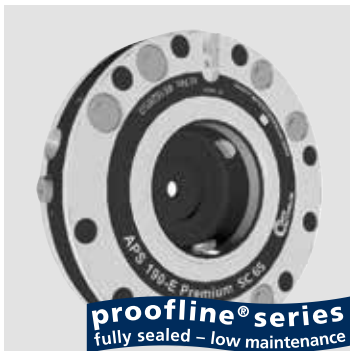

Zero Point Clamping Module

Technical features

- 3 Clamping slides
- TURBO function **T** to increase the clamping force
- Anti-rotation key seat
- Air sensing **P**
- Pneumatic stroke control **SC**
- n.6 seats **B C D E F G** prepared to mount pneumatics/hydraulics couplers (71718106)

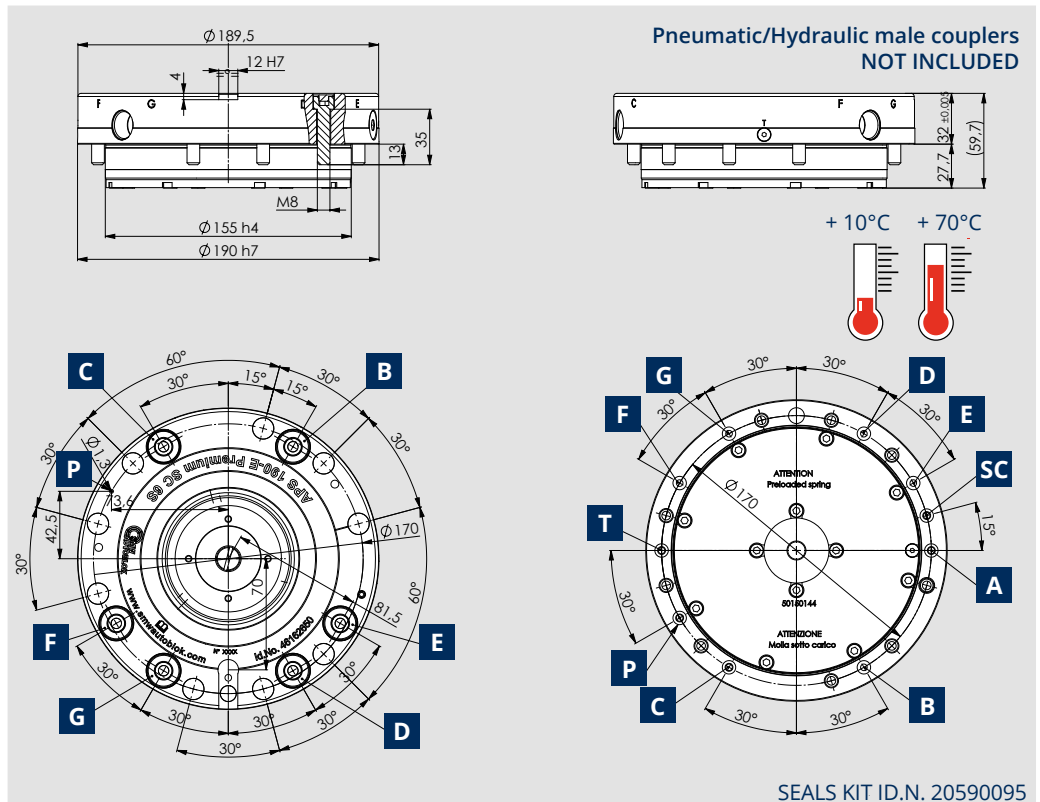

A = Open

ID.No.	Pull down force	Holding force (*)	Unlocking pressure	Repeatability	Weight
46162650	13,5 / 45** kN	50(M12) 75(M16) 80(6xM6) 150(6xM8) kN	6 bar	< 0,005 mm	6,9 Kg

Drawings and data are subject to change by SMW-Autoblok.

APS 250 E PREMIUM SC - ID.N. 46165030 with pneumatic stroke control



Zero Point Clamping Module

Technical features

- 6 Clamping slides
- TURBO function **T** to increase the clamping force
- Anti-rotation key 46165018
- Air sensing **P**
- Pneumatic stroke control **SC**

A = Open

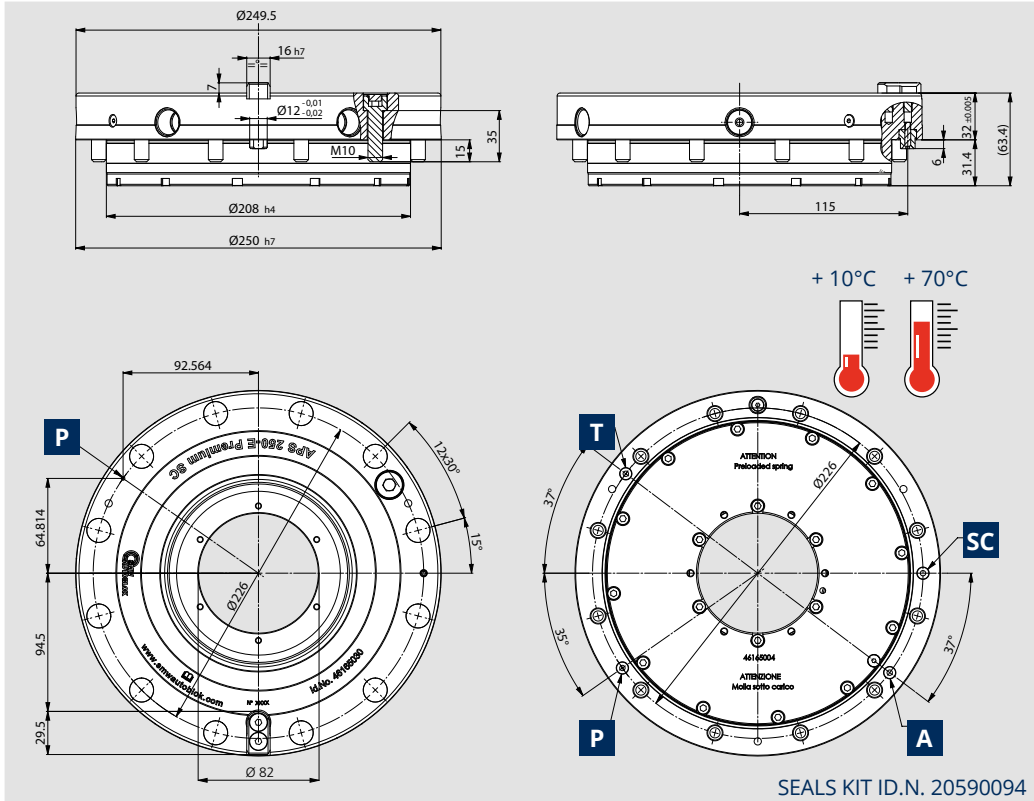

ID.No.	Pull down force	Holding force (*)	Unlocking pressure	Repeatability	Weight
46165030	18 / 55** kN	300(6xM12) 210(6xM10) 375(15xM8) kN	6 bar	< 0,005 mm	15 kg

(*) with screws DIN EN ISO 4762 - 12.9 / (***) with "turbo effect"



APS summary divided by increasing functional levels

Product range	APS classification	Size	Clamping slides	Turbo	Air cleaning	Stroke control	Air sensing	Key Seat	Feedings	+10°C + 70°C
BASIC	BASIC	100	2							
		140	2							
PREMIUM LIGHT	PREMIUM LIGHT	140	3							
	PREMIUM LIGHT SC	140	3							
		160	3							
PREMIUM	PREMIUM	100	2							
	PREMIUM SC	140	3							
		190	3							
		250	6					+ key		
	PREMIUM SC-6S	160	3							
		190	3							
APS 140 E VeSC		140	3							

Drawings and data are subject to change by SMW-Autoblok.

CLAMPING PINS

Positioning and clamping of the devices and/or of the workpiece are achieved through the clamping pins.

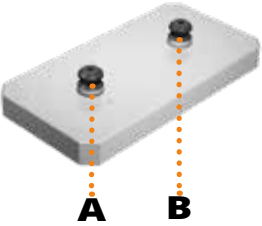
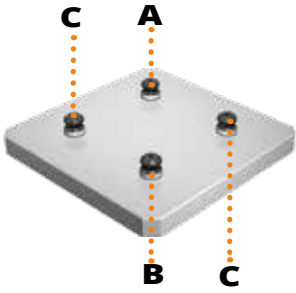
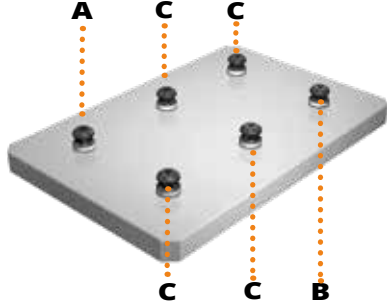
TYPE A Centering pin	TYPE B Reference pin	TYPE C Pull-down pin $\pm 0,05$ mm
 <p>used for centering and clamping</p>	 <p>used for reference and clamping</p>	 <p>only for clamping</p>
		

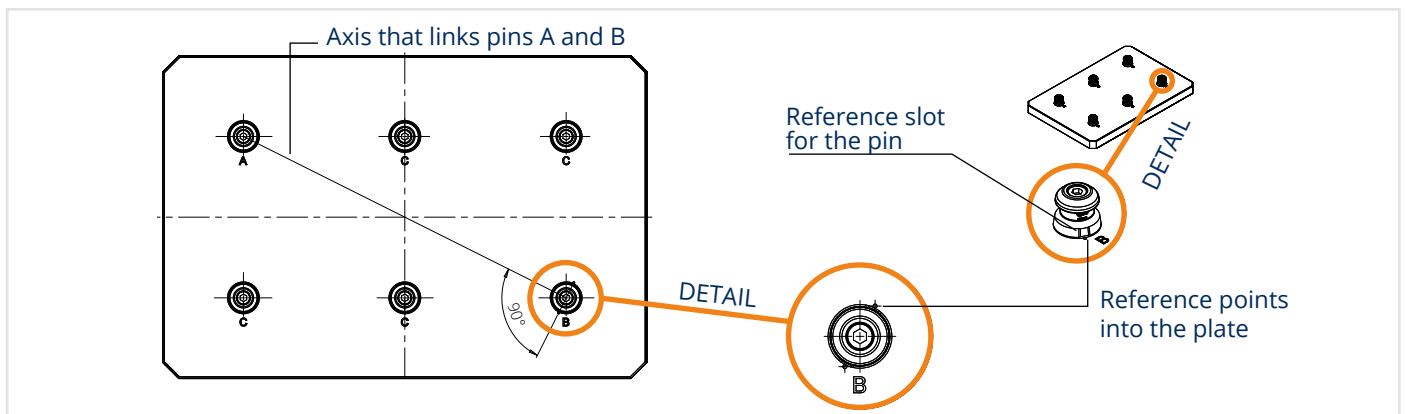

Tightening torque for pins mounting bolts

BOLTS	Nm
M6	13
M8	35
M10	60
M12	110
M16	200

Pins for APS 100

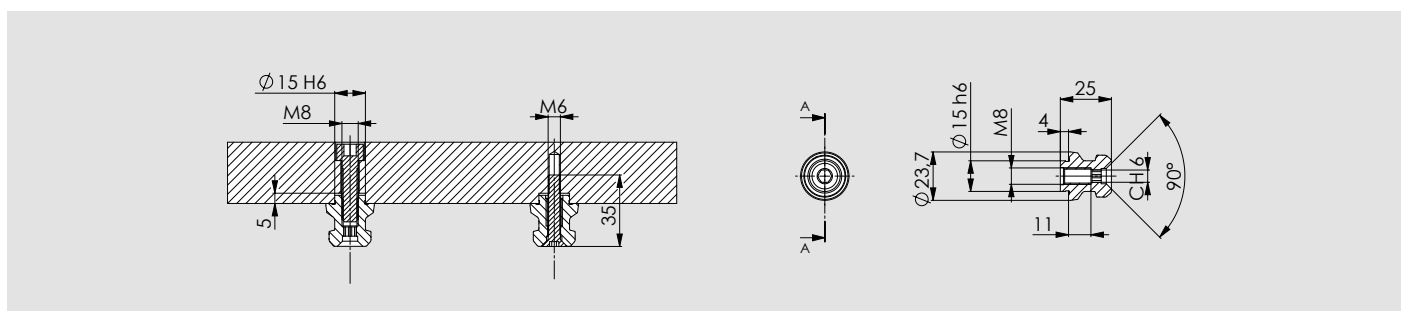

ID.N.	TYPE		WEIGHT
46 16 21 55	A	M8	0,05 Kg
46 16 21 56	B	M8	0,05 Kg
46 16 21 57	C	M8	0,05 Kg

Pins for APS 140 M12 thread

Compatible with
Unilock/Vero-S
system

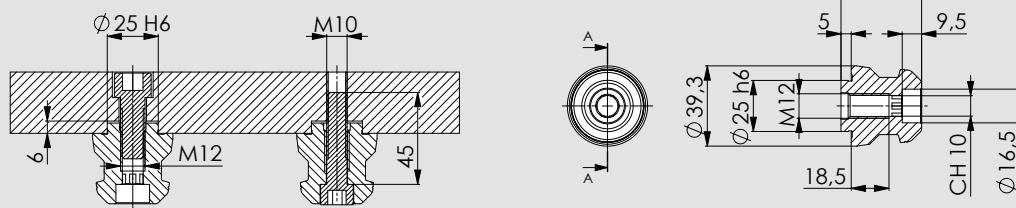

ID.N.	TYPE		WEIGHT
46 16 23 55	A	M12	0,2 Kg
46 16 23 56	B	M12	0,2 Kg
46 16 23 57	C	M12	0,2 Kg

Pins for APS 140 M16 thread

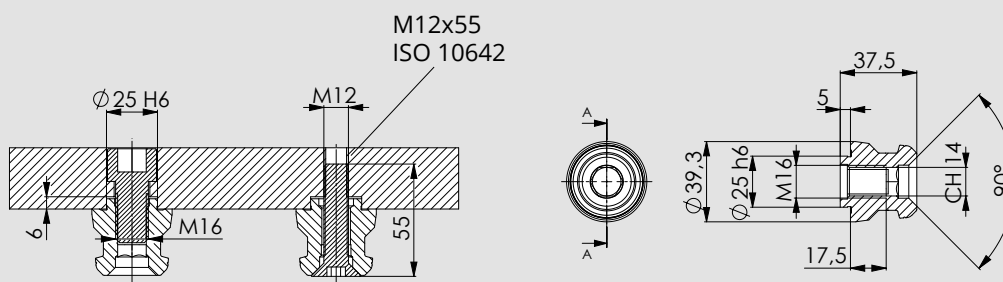

ID.N.	TYPE		WEIGHT
46 16 24 55	A	M16	0,2 Kg
46 16 24 56	B	M16	0,2 Kg
46 16 24 57	C	M16	0,2 Kg

Pins TYPE C floating for APS 140

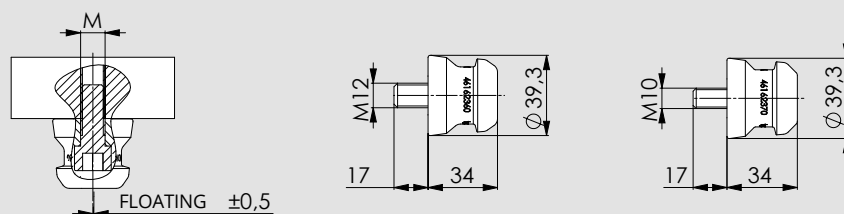

These pins don't require centering. They are floating only radially and not angularly.

ID.N.	TYPE		WEIGHT
46 16 23 70	C - FLOATING $\pm 0,5$ mm	M10	0,2 Kg
46 16 23 60	C - FLOATING $\pm 0,5$ mm	M12	0,2 Kg

Pins for APS 160 M16 thread

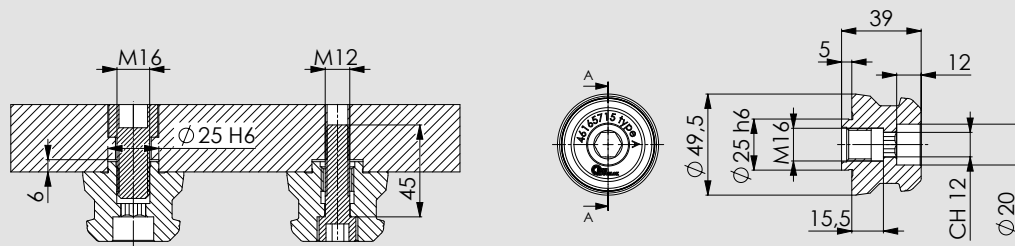

ID.N.	TYPE		WEIGHT
46 16 57 15	A	M16	0,35 Kg
46 16 57 16	B	M16	0,35 Kg
46 16 57 17	C	M16	0,35 Kg

Pins for APS 160 D17

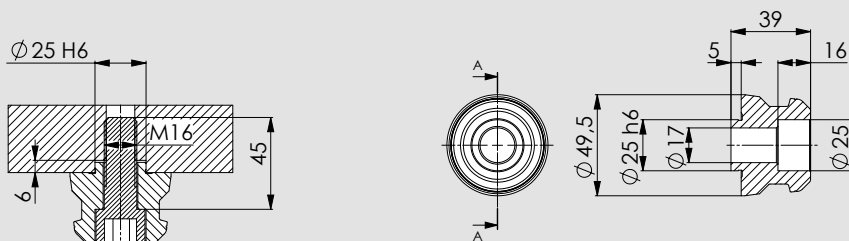

ID.N.	TYPE		WEIGHT
46 16 57 05	A	D17	0,3 Kg
46 16 57 06	B	D17	0,3 Kg
46 16 57 07	C	D17	0,3 Kg

Pins TYPE C floating for APS 160

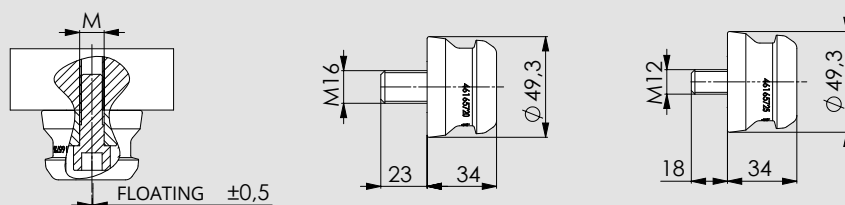

These pins don't require centering. They are floating only radially and not angularly.

ID.N.	TYPE		WEIGHT
46 16 57 20	C - FLOATING ± 0,5 mm	M16	0,4 Kg
46 16 57 25	C - FLOATING ± 0,5 mm	M12	0,35 Kg

Pins for APS 190

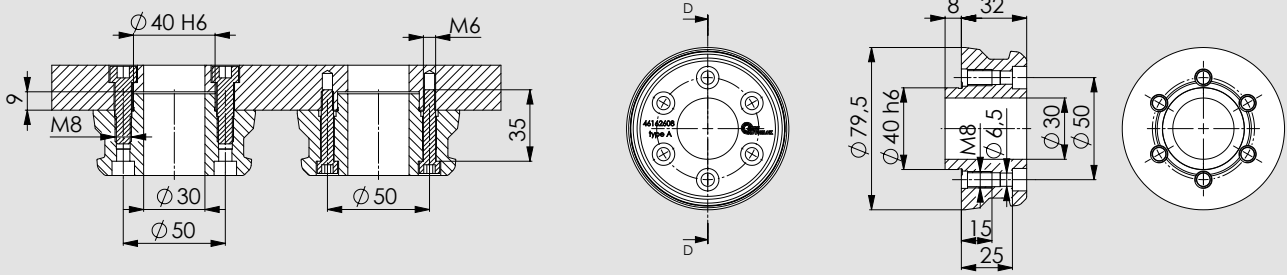

ID.N.	TYPE	WEIGHT	NOTE
46 16 26 08	A	0,85 Kg	Pin with central hole \varnothing 30

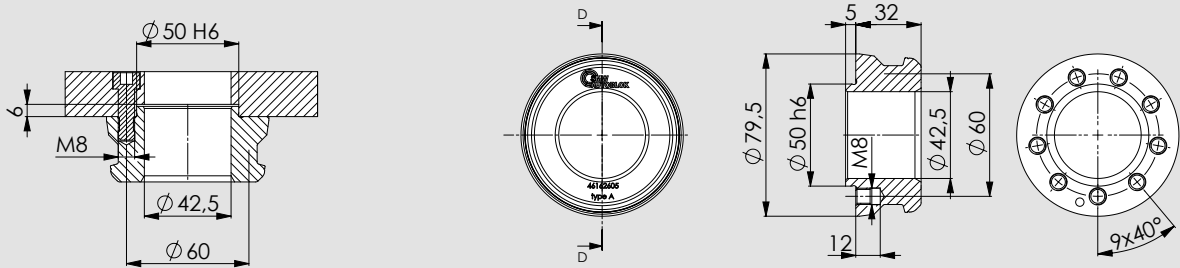

ID.N.	TYPE	WEIGHT	NOTE
46 16 26 05	A	0,7 Kg	Pin with central hole \varnothing 42

RECOMMENDED MOUNTING

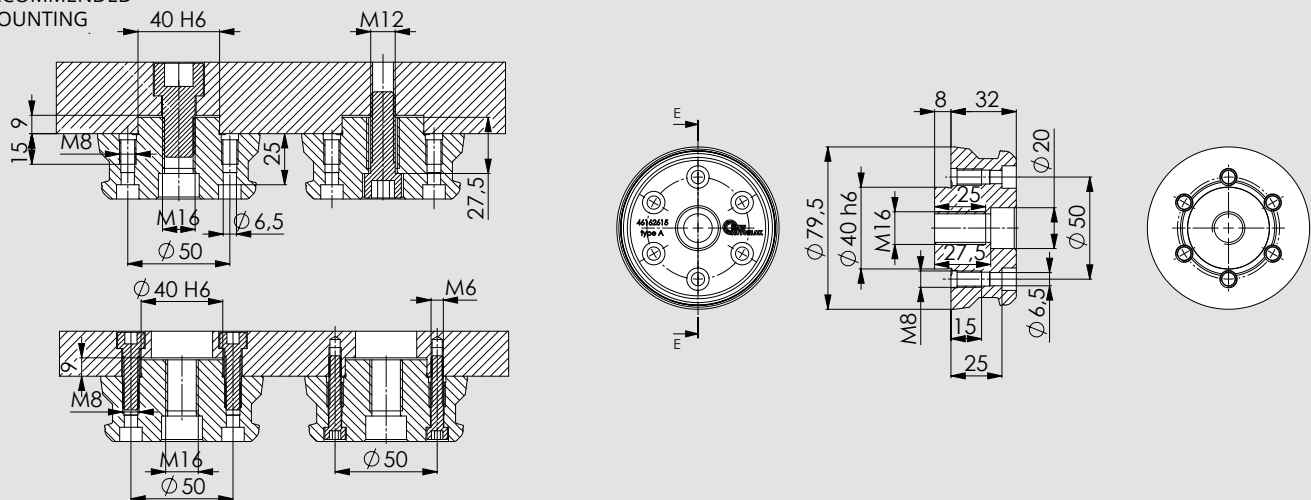

ID.N.	TYPE	WEIGHT
46 16 26 15	A	M16 1 kg
46 16 26 16	B	M16 1 kg
46 16 26 17	C	M16 1 kg

Pins for APS 190

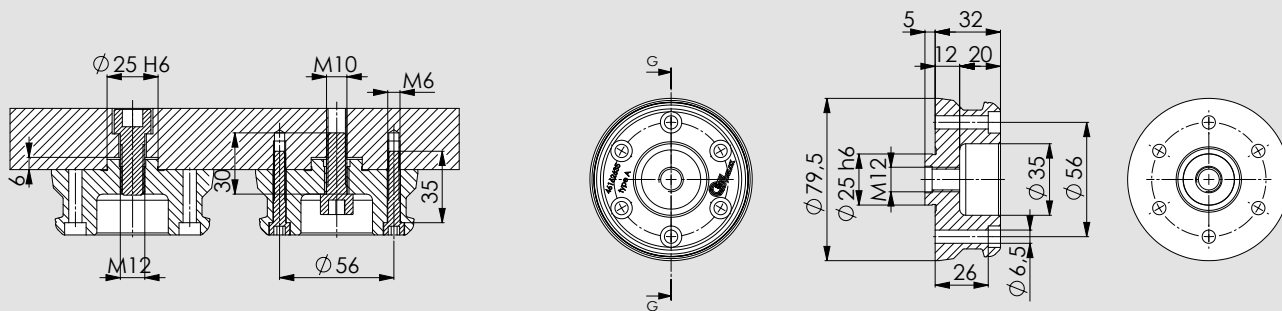

ID.N.	TYPE	WEIGHT
46 16 26 35	A Mounting pin = to the pin APS-140 M12	0,85 kg

Pins for APS 250

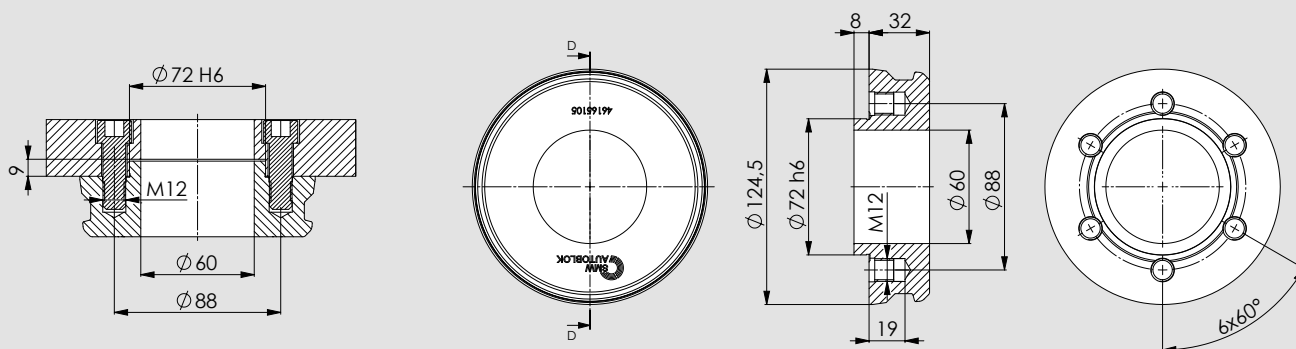

ID.N.	TYPE	WEIGHT	NOTE
46 16 51 05	A	2 Kg	Pin with central hole \varnothing 60

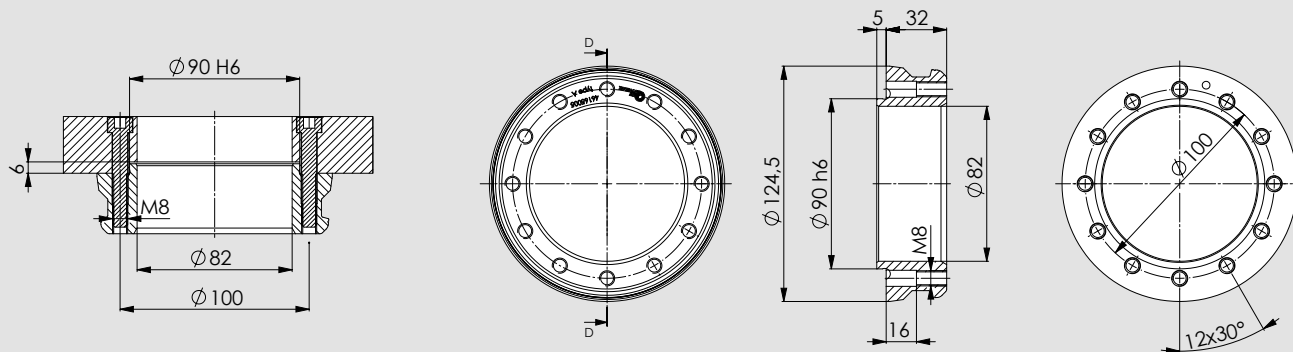

ID.N.	TYPE	WEIGHT	NOTE
46 16 50 05	A	1,3 Kg	Pin with central hole \varnothing 82

KEYS keys kit for all APS models

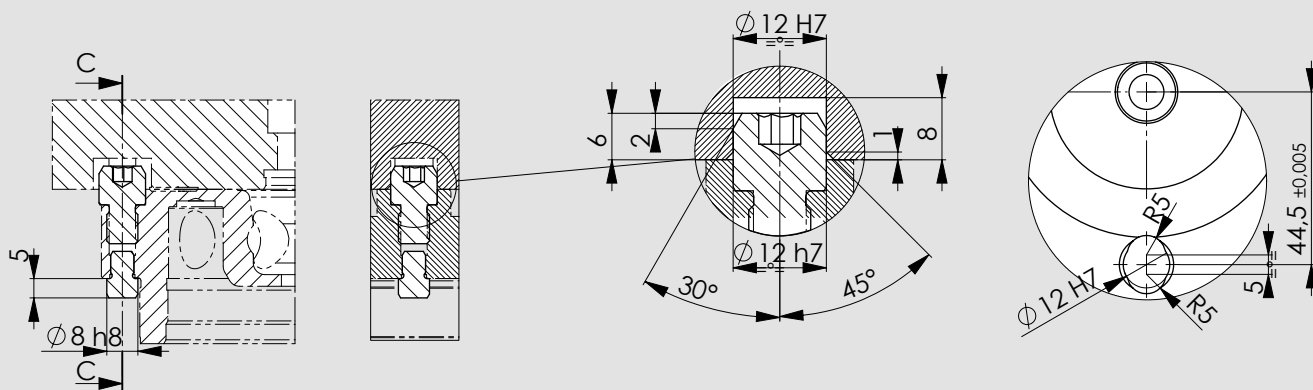

ID.N.

46162133 KEY KIT FOR APS 100

* The SEMIFINISHED KEY in the part that comes out from APS is supplied increased to 12,5mm to be finished to 12h7.

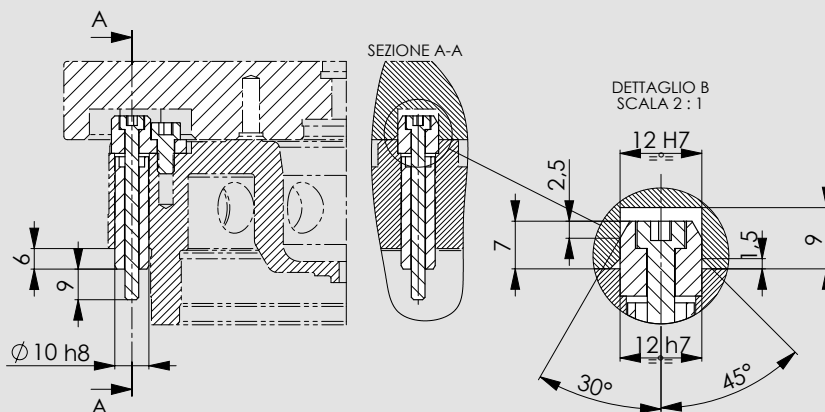

ID.N.

46162333 KEY KIT FOR APS 140E / APS 190E

* 46162335 KEY KIT SMF 12,5 APS 140E / APS 190E

MAGNET PROTECTION COVERS for all APS models

FOR BASIC MODULE
FOR PREMIUM LIGHT MODULE

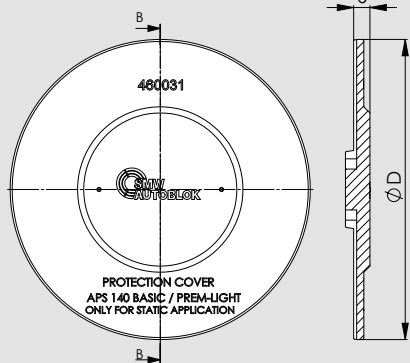

NON
ROTATING

ONLY FOR
STATIC
APPLICATION

FOR PREMIUM MODULE
with key mounted

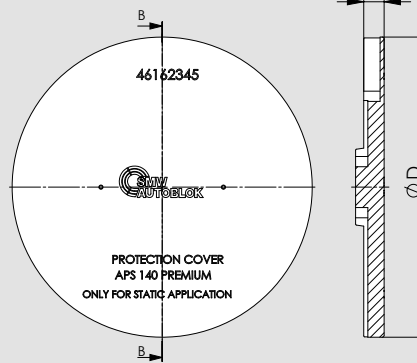

NON
ROTATING

ONLY FOR
STATIC
APPLICATION

ID.N.	MODEL	S	ØD	WEIGHT
460030*	MAGNET PROTECTION COVER FOR APS 100 BASIC	8	107	0,45 Kg
460031*	MAGNET PROTECTION COVER FOR APS 140 BASIC	8	147	0,8 Kg
46165730*	MAGNET PROTECTION COVER FOR APS 160 PREMIUM LIGHT	8	167	1 Kg

ID.N.	MODEL	S	ØD	WEIGHT
460030*	MAGNET PROTECTION COVER FOR APS 100 PREMIUM	8	107	0,45 Kg
46162345**	MAGNET PROTECTION COVER FOR APS 140 PREMIUM	10	147	0,45 Kg
46162625**	MAGNET PROTECTION COVER FOR APS 190 PREMIUM	10	197	0,85 Kg
46165033**	MAGNET PROTECTION COVER FOR APS 250 PREMIUM	10	257	1,5 Kg

NOTE: all APS Premium covers can be mounted on the Basic model.

* Steel ** Aluminium

2

MODULE HEIGHT EXTENSION APS and CLAMPING UNIT APS

24

CLAMPING UNIT APS

Without integrated feedings configuration possible scheme.

30

SAB-1

Safety valve standard and visual check (optional).
Operation valve scheme.

34

CLAMPING UNIT FOR MULTIPLE APS

Without integrated feedings on machine (for
example 3 axis machines). 1 FEEDING.

35

CLAMPING UNIT FOR MULTIPLE APS

Without integrated feedings on machine (for
example 3 axis machines). 2 FEEDINGS.

37

CLAMPING UNIT FOR MULTIPLE APS

Without integrated feedings on machine (for
example 3 axis machines). 3 FEEDINGS.

40

CLAMPING UNIT WITH 4 APS

Possible configurations scheme for 5 axis
machines 2-4-6 FEEDINGS.

MODULE HEIGHT EXTENSION



CLAMPING UNIT

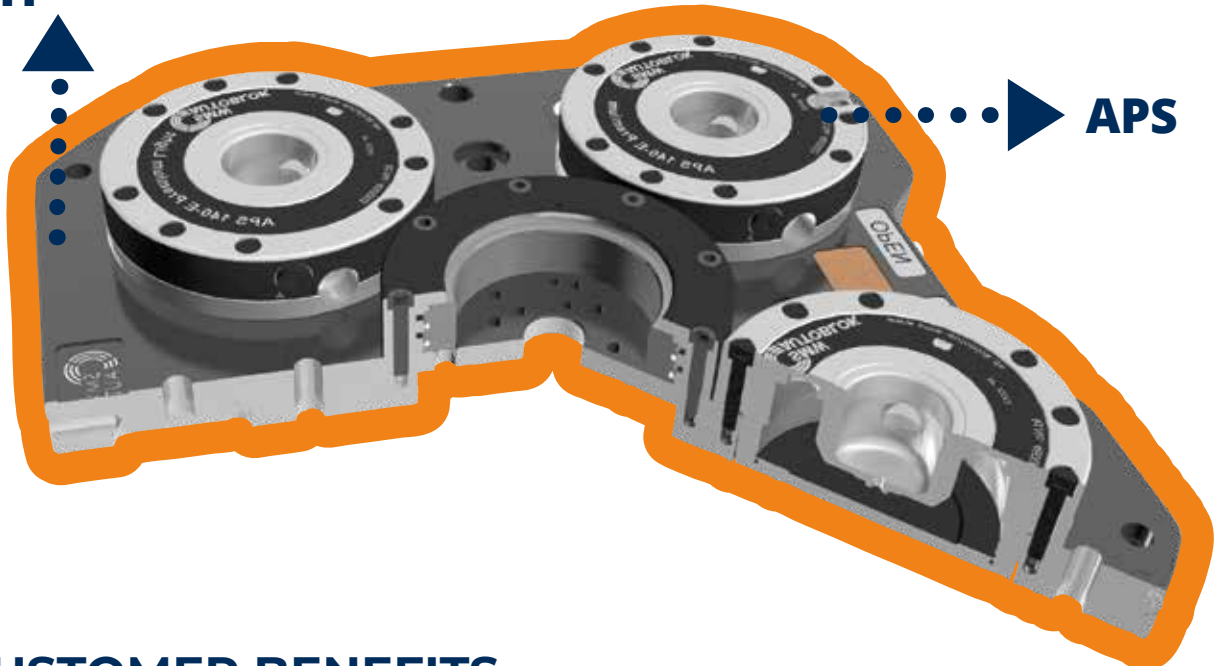

CUSTOMER BENEFITS

- ▶ Pre-assembled clamping unit with some types of APS (see next table)
- ▶ For 5-axis machining center
- ▶ Universal applicable
- ▶ Fast and easy set-up
- ▶ Repeatability < 0.005 mm
- ▶ Distribution plate for media feed (pneumatic / hydraulic) 6 channels



CLAMPING UNIT

2

Types	Id.n.	APS size						n. of APS	Height	SAB-1 std	available for n. axis		Weight
		100 E-PREMIUM	140 BASIC	140 E-PREMIUM	140 PREMIUM LIGHT	140 PREMIUM LIGHT SC	190 E-PREMIUM		H		3	5	
MODULE HEIGHT EXTENSION	460110							1	H65			6 Kg	
	460112							1	H60			8 Kg	
	460113							1	H80			11 Kg	
	460114							1	H120			14 Kg	
	460115							1	H180			18 Kg	
	460111							1	H100			20,5 Kg	
	46203030							1	H100			12 Kg	
	46203020							1	H100			18 Kg	
	46203040							1	H76			8,3 Kg	
	41702150							1	H76			14,5 Kg	
	46203000							6 feedings	H95			10,5 Kg	
CLAMPING UNIT	46202210		1 feeding					2	H60			21 Kg	
	46202200		1 feeding					4	H60			42 Kg	
	460020				2 feedings			2	H60			21 Kg	
	460021		2 feedings					2	H60			21 Kg	
	460022				2 feedings			4	H60			41 Kg	
	460023		2 feedings					4	H60			41 Kg	
	46186672				2 feedings			6	H60			64 Kg	
	46186674		2 feedings					6	H60			64 Kg	
	46202230					3 feedings		2	H60			21 Kg	
	46202220					3 feedings		4	H60			41 Kg	
	46202000					2/4/6 feedings		4	H60			43 Kg	

MODULE HEIGHT EXTENSION

without integrated feedings configuration possible scheme

APS 100 E PREMIUM
(1 KEY)



460005

CONFIGURATION ONE

**Module Height Extension
APS 100**



APS 140 E PREMIUM
(1 KEY)



460002

CONFIGURATION ONE

**Module Height Extension
APS 140**



CONFIGURATION TWO

**Module Height Extension
APS 140
with SAB-1 std valve**



APS 190 E PREMIUM
(1 KEY)



46165640

CONFIGURATION ONE

**Module Height Extension
APS 190**



CONFIGURATION TWO

**Module Height Extension
APS 190
with SAB-1 std valve**



T-NUTS SET
optional

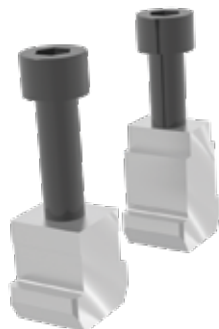

ATTENTION: the pneumatic system of the pressure switch must signal the alarm condition and must prevent the pallet exchange on the APS or any robot operation when the inlet pressure is less than 6 bar.

MODULE HEIGHT EXTENSION with one APS 100 E PREMIUM

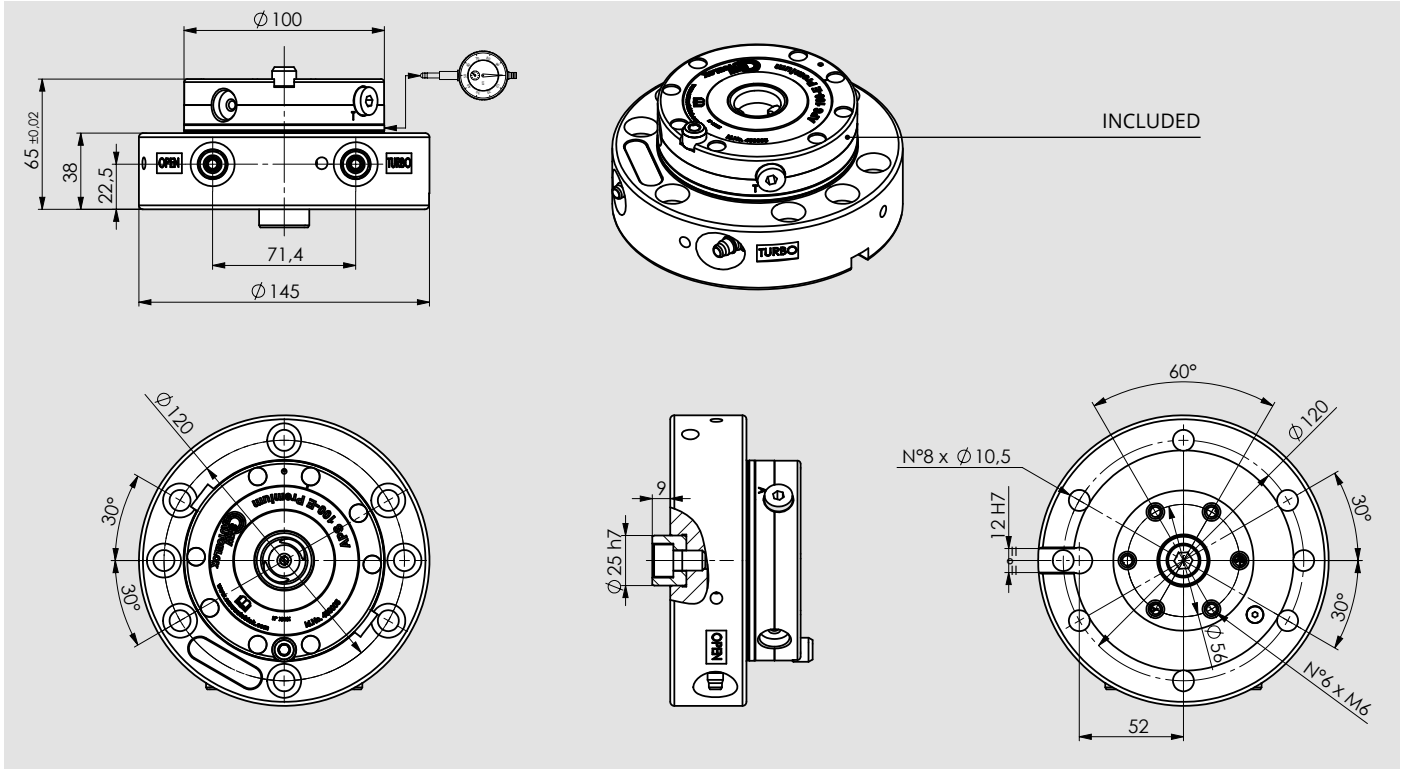

ID.N. MODULE HEIGHT EXTENSION (APS INCLUDED)

460110 MODULE EXTENSION APS 100 PREMIUM H65

HEIGHT

65 mm

WEIGHT

6 Kg

NOTE 1: for every unit is included the key Id.n. 46162133 (APS chapter).

NOTE 2: OPTIONALS T-nuts set: - 46204100 with T-slot 12 / - 46204101 with T-slot 14 / - 46204102 with T-slot 18.

NOTE 3: the module height extension can also be mounted on APS 140 using the pin 46162355 (ONE APS PALLET chapter).

NOTE 4: when use the module in rotation (rpm 200-1000) request balancing (listed separately).

NOTE 5: the module extension is equipped with radial screws for the fine centering of the APS.

MODULE HEIGHT EXTENSION with one APS 140 E PREMIUM

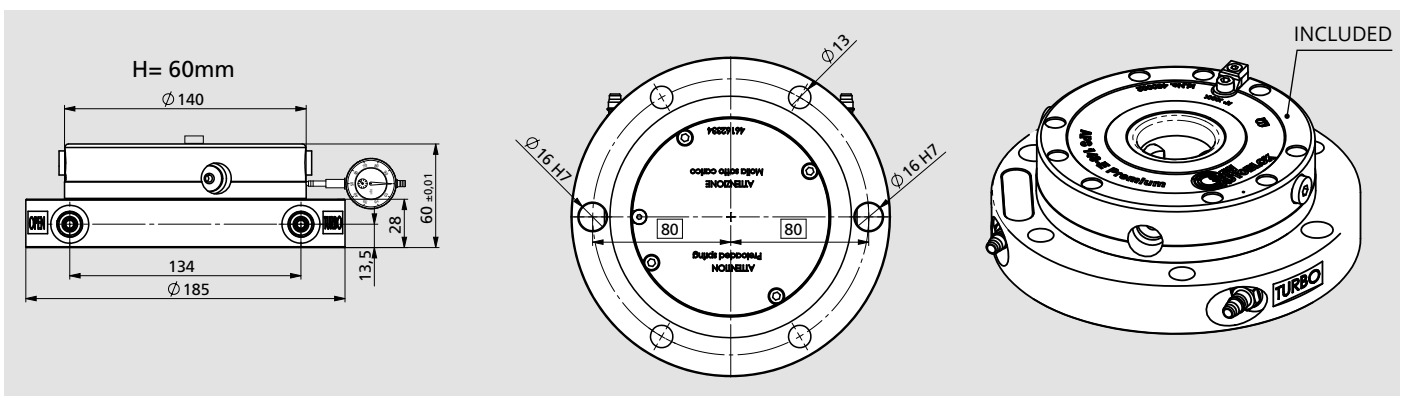

ID.N. MODULE HEIGHT EXTENSION (APS INCLUDED)

460112 MODULE EXTENSION APS 140 PREMIUM H60

HEIGHT

60 mm

WEIGHT

8 Kg

NOTE 1: for every unit is included the key Id.n. 46162333 (APS chapter)

MODULE HEIGHT EXTENSION with APS 140 E PREMIUM

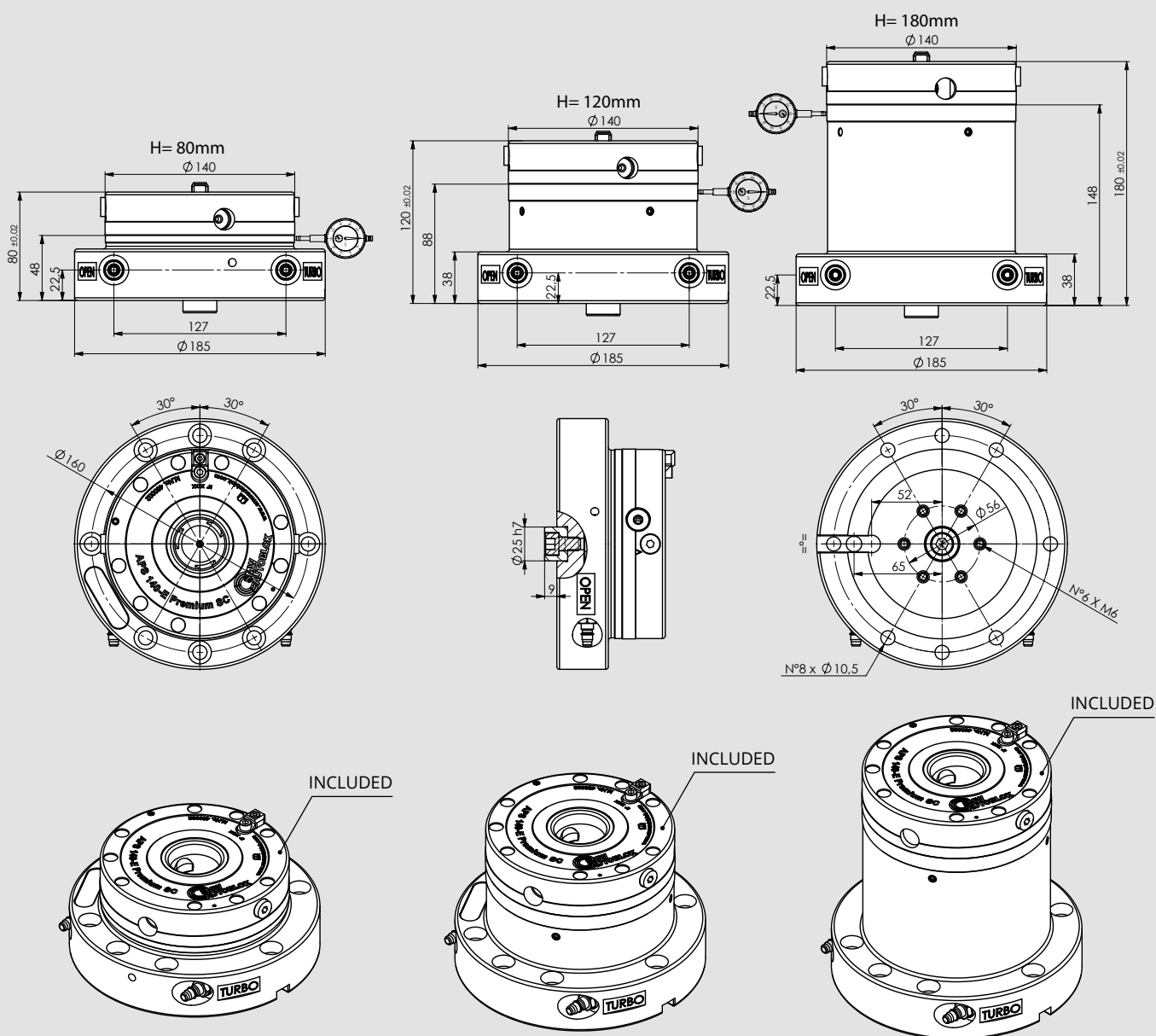

ID.N. MODULE HEIGHT EXTENSION (APS INCLUDED)	HEIGHT	WEIGHT
460113 MODULE EXTENSION APS 140 PREMIUM H80	80 mm	11 Kg
460114 MODULE EXTENSION APS 140 PREMIUM H120	120 mm	14 Kg
460115 MODULE EXTENSION APS 140 PREMIUM H180	180 mm	18 Kg

NOTE 1: for every unit is included the key Id.n. 46162333 (APS chapter).

NOTE 2: OPTIONALS T-nuts set: - 46204100 with T-slot 12 / - 46204101 with T-slot 14 / - 46204102 with T-slot 18.

NOTE 3: the module height extension can also be mounted on APS 140 and APS 190 using respectively the pins 46162355 (APS 140) and 46162635 (APS 190) (ONE APS PALLET chapter).

NOTE 4: when use the module in rotation (rpm 200-1000) request balancing (listed separately).

NOTE 5: the module extension is equipped with radial screws for the fine centering of the APS.

MODULE HEIGHT EXTENSION with APS 190 E PREMIUM

2

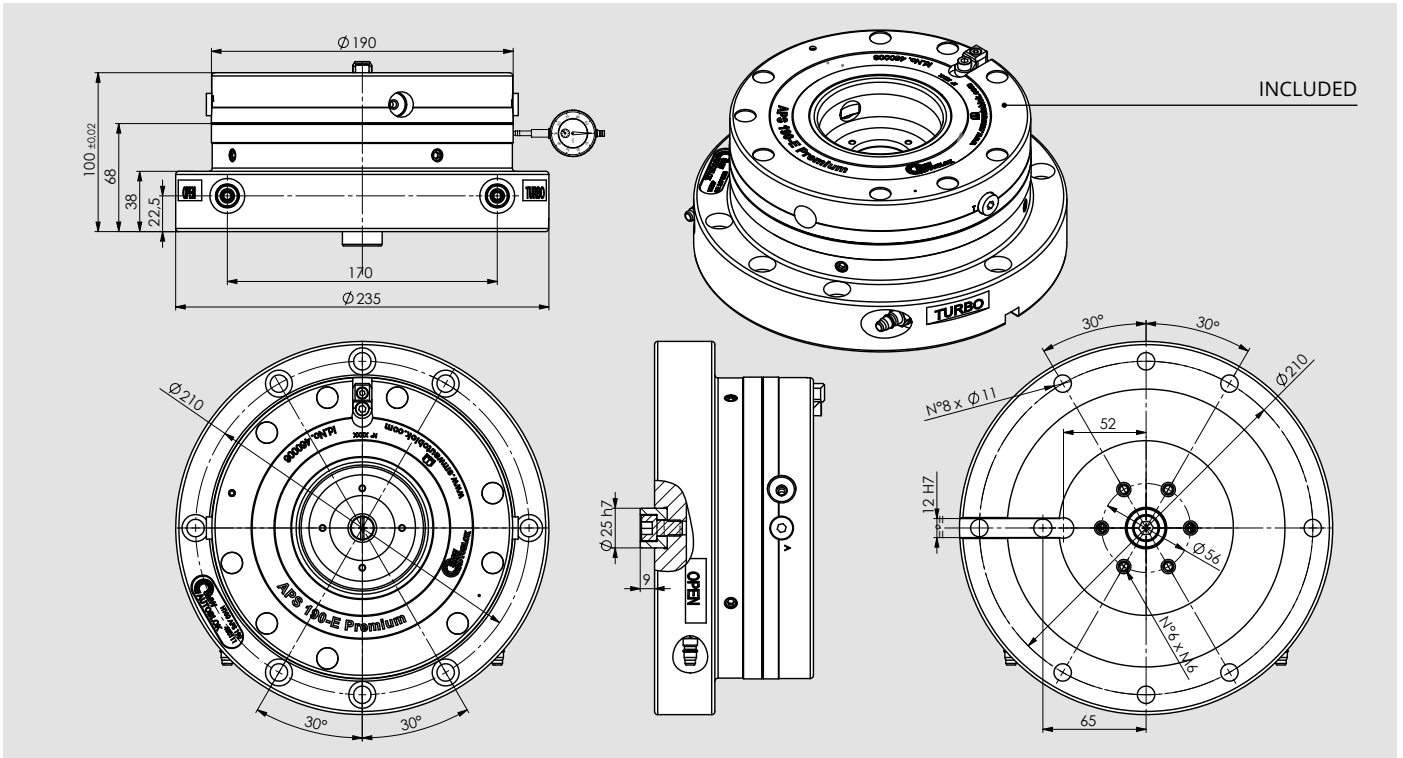

ID.N. MODULE HEIGHT EXTENSION (APS INCLUDED)	HEIGHT	WEIGHT
460111 MODULE EXTENSION APS 190 PREMIUM H100	100 mm	20,5 Kg

NOTE 1: for every unit is included the key Id.n. 46162333 (APS chapter).

NOTE 2: OPTIONALS T-nuts set: - 46204100 with T-slot 12 / - 46204101 with T-slot 14 / - 46204102 with T-slot 18.

NOTE 3: the module height extension can also be mounted on APS 140 and APS 190 using respectively the pins 46162355 (APS 140) and 46162635 (APS 190) (ONE APS PALLET chapter)

NOTE 4: when use the module in rotation (rpm 200-1000) request balancing (listed separately).

NOTE 5: the module extension is equipped with radial screws for the fine centering of the APS.

MOUNTING EXAMPLES

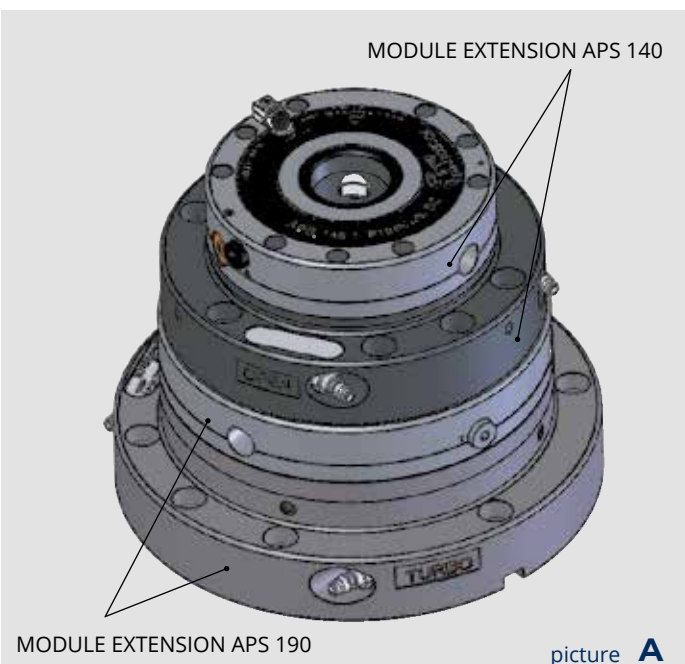

Application example with module extension **APS140 460113** mounted on the module extension **APS190 460111**

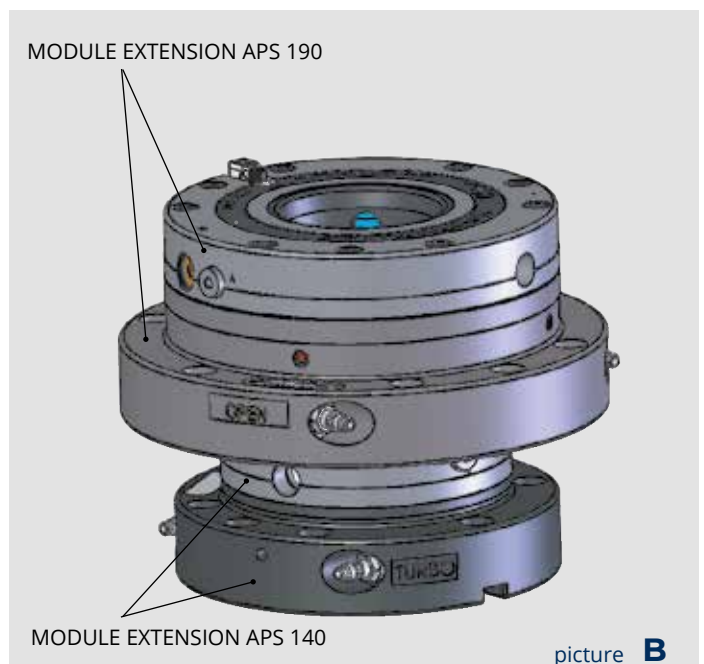

Application example with module extension **APS190 460111** mounted on the module extension **APS140 460113**

ONE APS WITH SAB-1 VALVE MODULE HEIGHT EXTENSION with APS 140

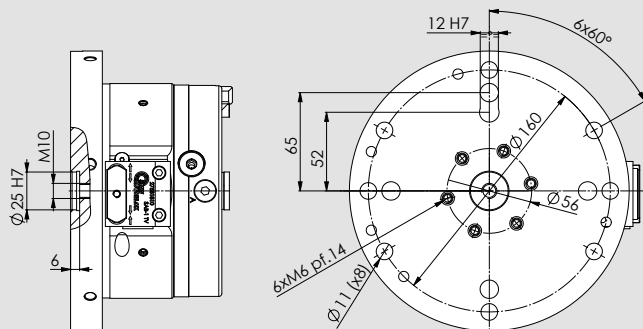
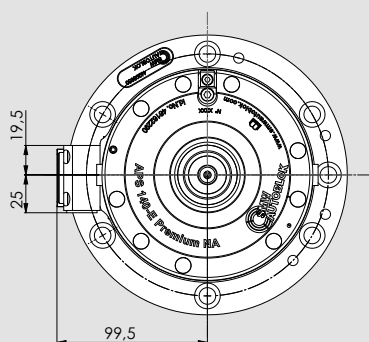
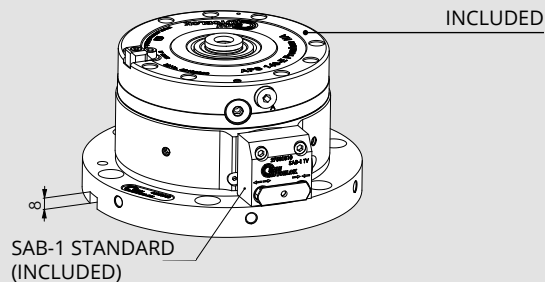
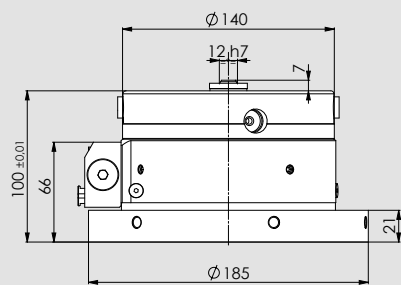

ID.N. MODULE HEIGHT EXTENSION (APS AND SAB-1 STANDARD INCLUDED)

46203030 MODULE HEIGHT EXTENSION APS 140 E PREMIUM H100 + SAB-1

HEIGHT

100 mm

WEIGHT

12 Kg

NOTE 1: when use the module in rotation (rpm 200-1000) request balancing (listed separately).

NOTE 2: the module extension is equipped with radial screws for the fine centering of the APS.

NOTE 3: the module height extension can also be mounted on APS 140 and APS 190 using respectively the pins 46162355 (APS 140) and 46162635 (APS 190) (ONE APS PALLET chapter).

ONE APS WITH SAB-1 VALVE MODULE HEIGHT EXTENSION with APS 190

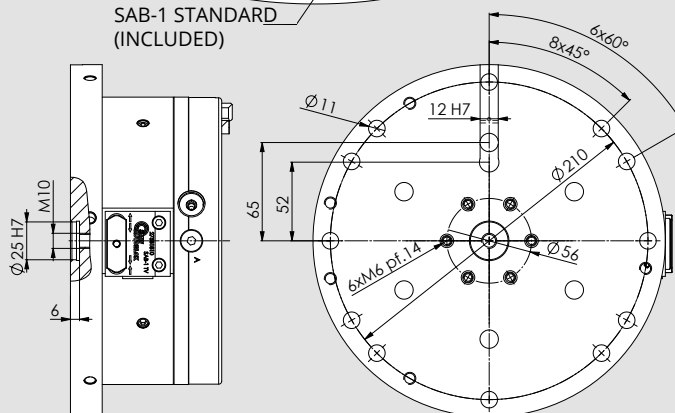
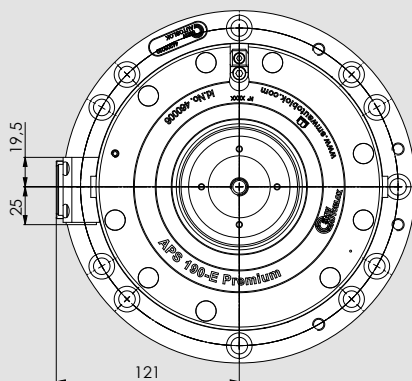
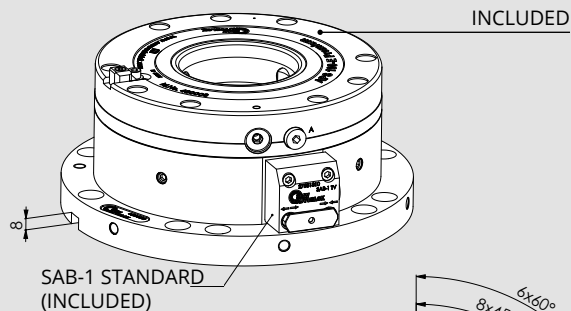
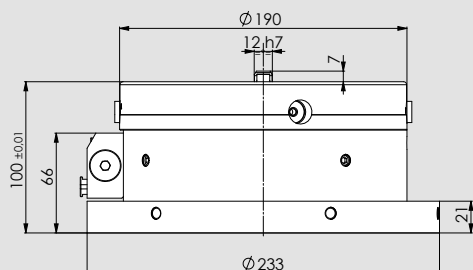

ID.N. MODULE HEIGHT EXTENSION (APS AND SAB-1 STANDARD INCLUDED)

46203020 MODULE HEIGHT EXTENSION APS 190 E PREMIUM H100 + SAB-1

HEIGHT

100 mm

WEIGHT

18 Kg

NOTE 1: when use the module in rotation (rpm 200-1000) request balancing (listed separately).

NOTE 2: the module extension is equipped with radial screws for the fine centering of the APS.

NOTE 3: the module height extension can also be mounted on APS 140 and APS 190 using respectively the pins 46162355 (APS 140) and 46162635 (APS 190) (ONE APS PALLET chapter).

ONE APS WITH SAB-1 VALVE D130 MODULE HEIGHT EXTENSION with APS 140

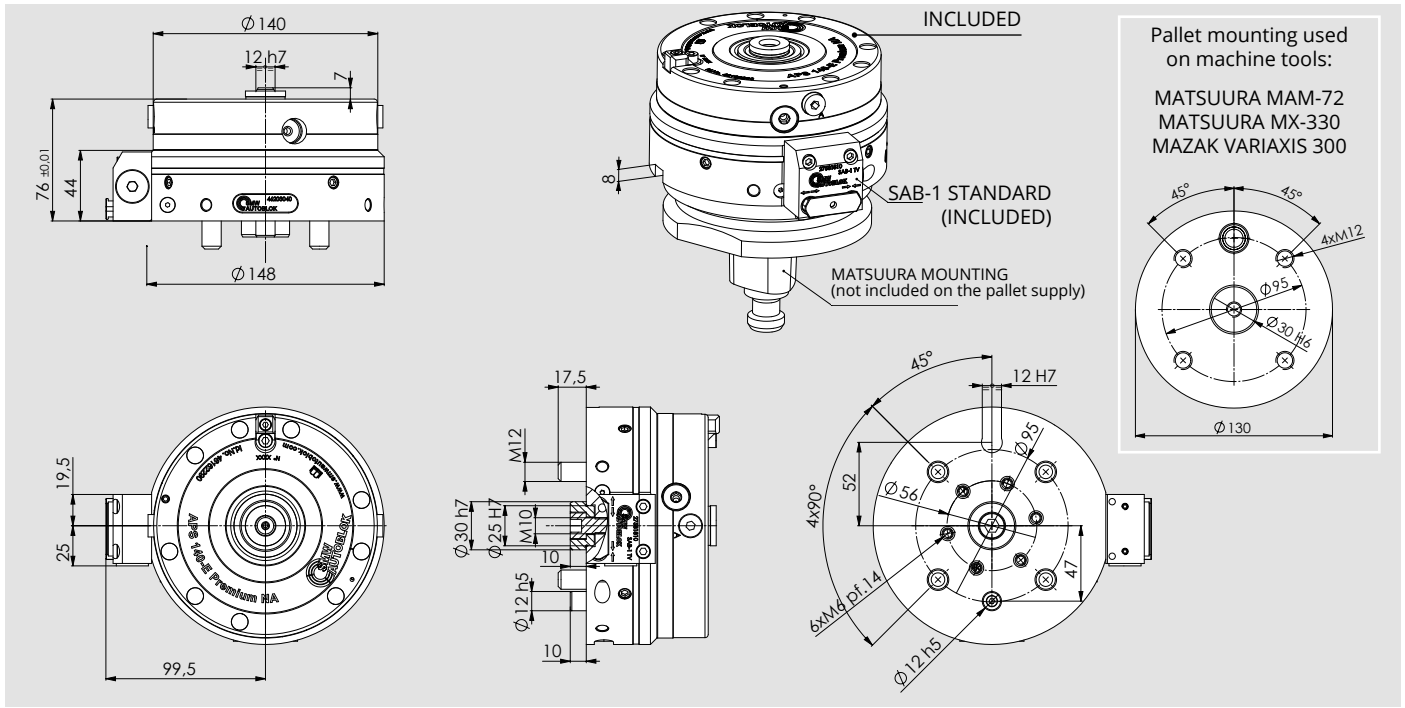

ID.N. MODULE HEIGHT EXTENSION (APS AND SAB-1 STANDARD INCLUDED)

HEIGHT

WEIGHT

46203040 MODULE HEIGHT EXTENSION ONE APS 140 E PREMIUM H76 + SAB-1

76 mm

8,3 Kg

NOTE 1: when use the module in rotation (rpm 200-1000) request balancing (listed separately).

NOTE 2: the module extension is equipped with radial screws for the fine centering of the APS.

NOTE 3: the module height extension can also be mounted on APS 140 using the pin 46162355 (ONE APS PALLET chapter).

ONE APS WITH SAB-1 VALVE D130 MODULE HEIGHT EXTENSION with APS 190

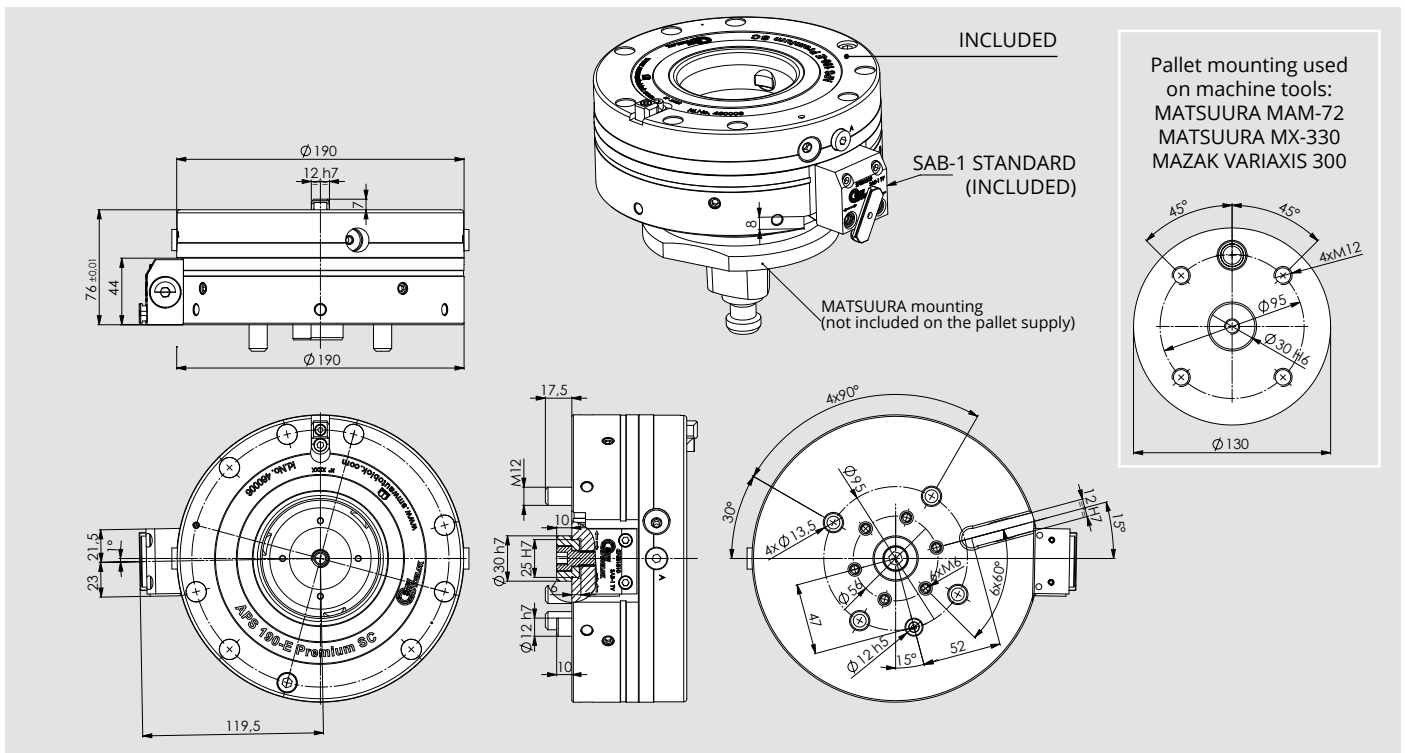

ID.N. MODULE HEIGHT EXTENSION (APS AND SAB-1 STANDARD INCLUDED)

HEIGHT

WEIGHT

41702150 MODULE HEIGHT EXTENSION ONE APS 190 E PREMIUM H76 + SAB-1

76 mm

14,5 Kg

NOTE 1: when use the module in rotation (rpm 200-1000) request balancing (listed separately).

NOTE 2: the module extension is equipped with radial screws for the fine centering of the APS.

NOTE 3: the module height extension can also be mounted on APS 140 and APS 190 using respectively the pins 46162355 (APS 140) and 46162635 (APS 190) (ONE APS PALLET chapter).

SAB-1 safety valve

SAB-1 Valve
STANDARD
Id.N. 27581810



SAB-1 Valve visual
check OPTIONAL
Id.N. 27581815



The Safety valve SAB-1 maintains air pressure in the cylinder pallet transportation / storage or machining without feed.

The 27581815 is different from 27581810 for the red visual pin. This system permits to see when the valve is activated.

SAB-1 OPERATION

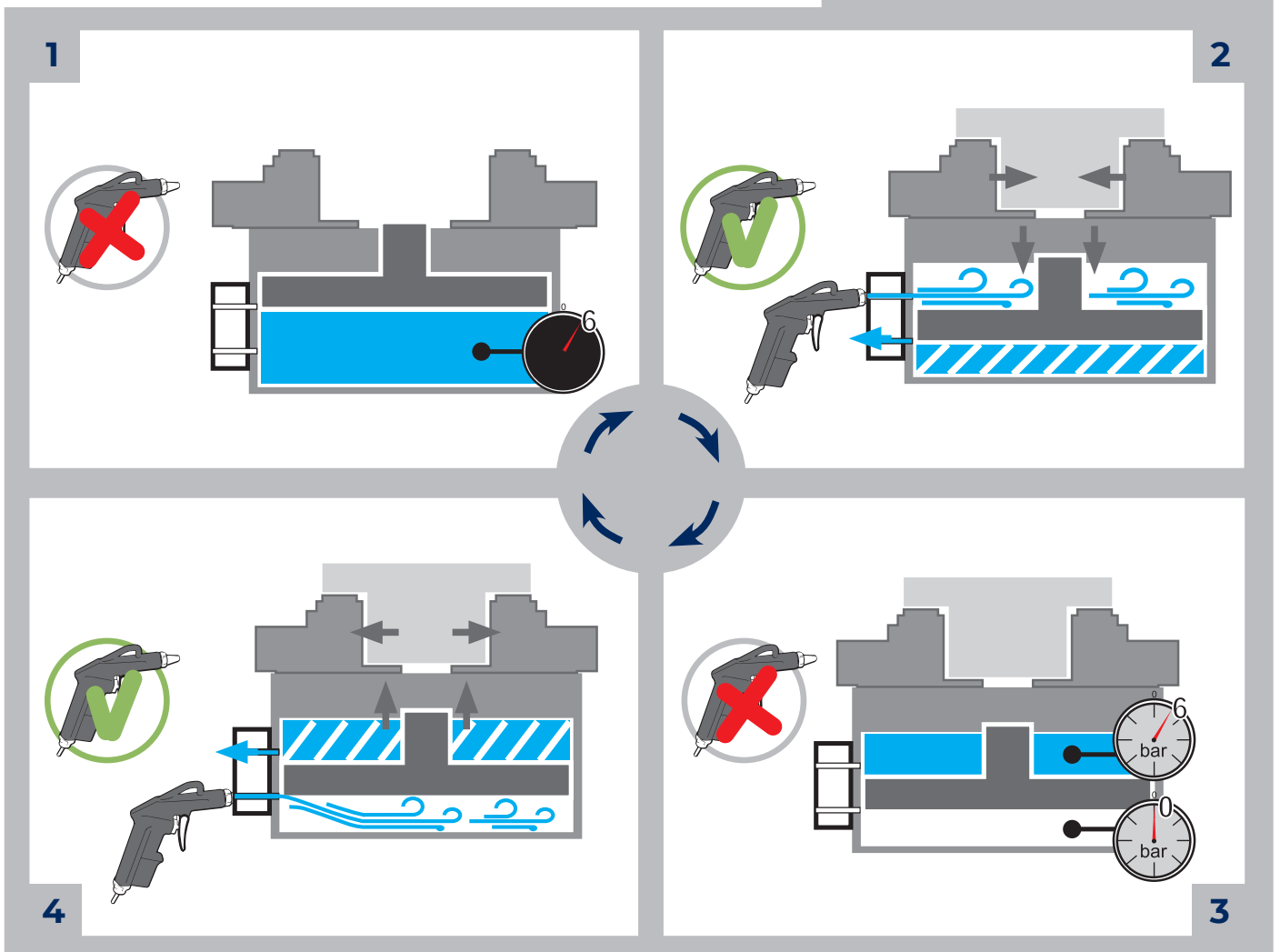

PNEUMATIC GUN with steel nozzle

Id.n. 41702140



Drawings and data are subject to change by SMW-Autoblok.

T-NUTS SET

for multiple plate APS and flange one APS

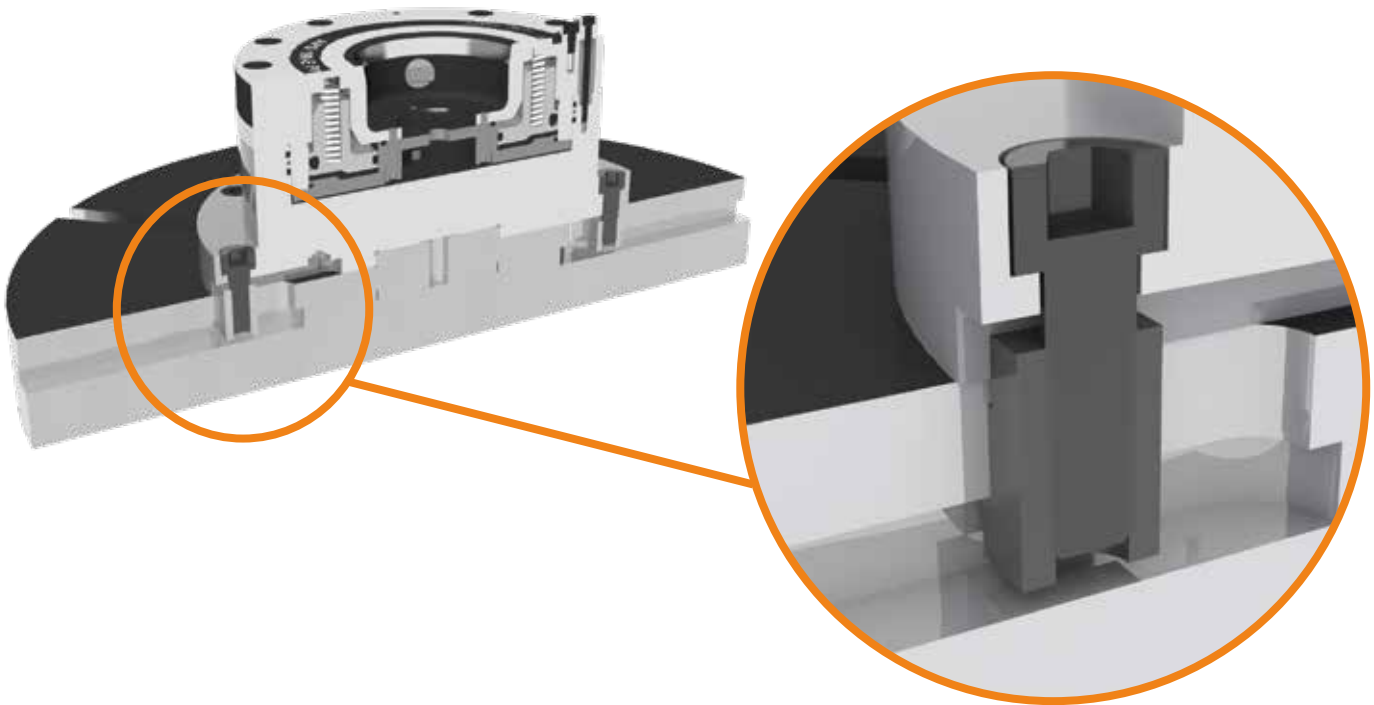

SET 9-T-NUTS T-SLOT 12
M10 for plate 4 APS 140

46204100

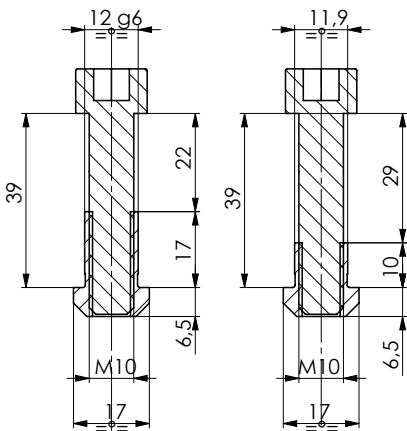

SET 9-T-NUTS T-SLOT 14
M10 for plate 4 APS 140

46204101

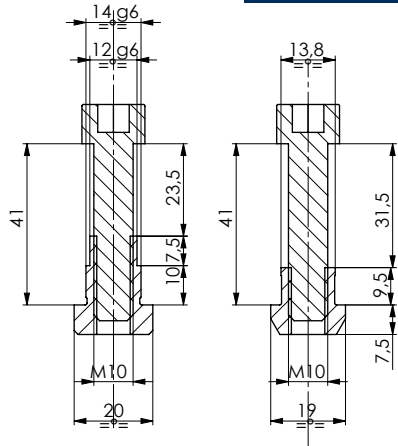

SET 9-T-NUTS T-SLOT 18
M10 for plate 4 APS 140

46204102

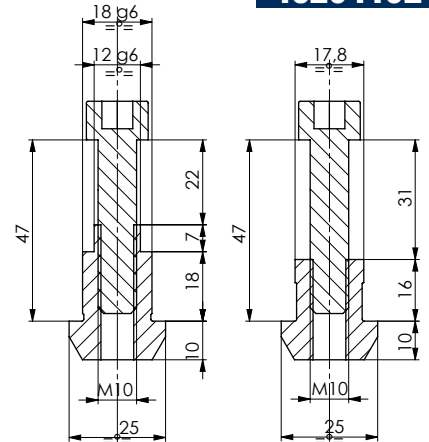

SET 8-T-NUTS T-SLOT 12
M10 for m.h.exten. one APS

46204103

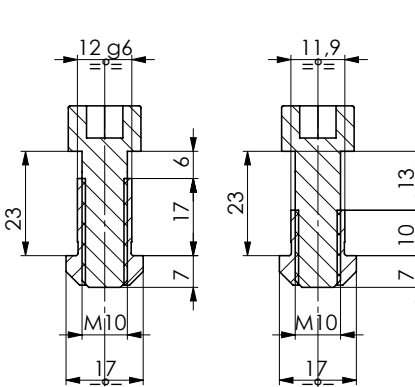

SET 8-T-NUTS T-SLOT 14
M10 for m.h.exten. one APS

46204104

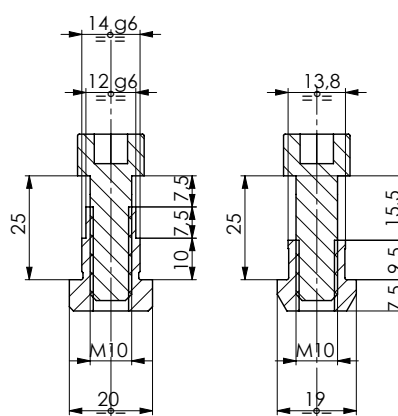

SET 8-T-NUTS T-SLOT 18
M10 for m.h.exten. one APS

46204105

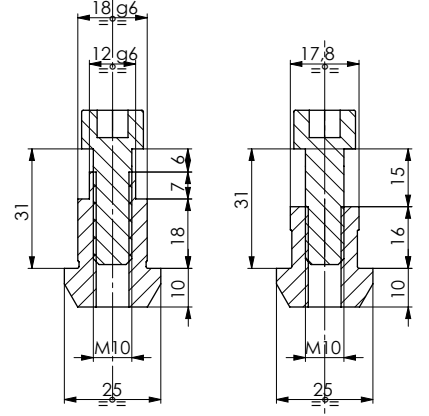

MODULE HEIGHT EXTENSION APS possible configurations scheme for 5 AXIS machine 2-4-6 FEEDINGS



MODULE HEIGHT EXTENSION COMPOSITION		2 FEEDINGS		4 FEEDINGS		6 FEEDINGS	
		ID.No.	Q.TY	ID.No.	Q.TY	ID.No.	Q.TY
1	MODULE HEIGHT EXTENSION GROUP	46203000	1	46203000	1	46203000	1
2	APS 190	46165640	1	46162650	1	46162650	1
3	KEY KIT	46162333	1	46162333	1	46162333	1
4	DISTRIBUTOR**	CUSTOMIZED	1	CUSTOMIZED	1	CUSTOMIZED	1
5	T-NUTS SET optional	to choose according to the T-Slot	1	to choose according to the T-Slot	1	to choose according to the T-Slot	1
6	MALE COUPLER*	-	-	71718106	2	71718106	4

* MALE COUPLER: the ID.n. refers to a single piece

** DISTRIBUTOR EXAMPLE: to be designed specifically for each machine until to 6 feedings

NOTE 1: When use the module in rotation (rpm 200-1000) request balancing (listed separately).

NOTE 2: The module extension is equipped with radial screws for the fine centering of the APS.

ATTENTION: the pneumatic system of the pressure switch must signal the alarm condition and must prevent the pallet exchange on the APS or any robot operation when the inlet pressure is less than 6 bar.

MODULE HEIGHT EXTENSION APS prepared for 5 AXIS machine until 6 FEEDINGS

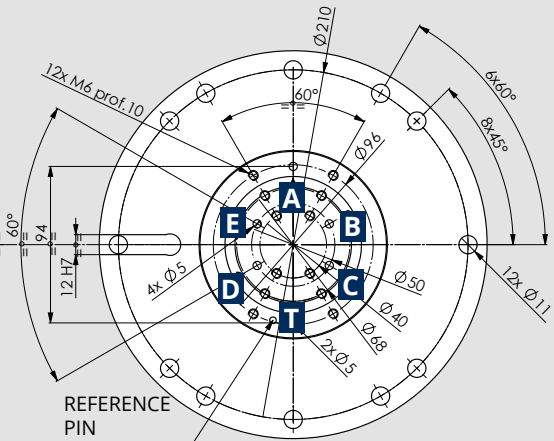
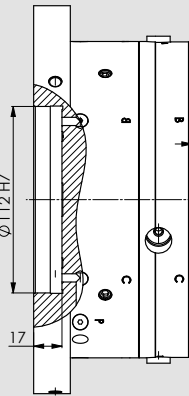
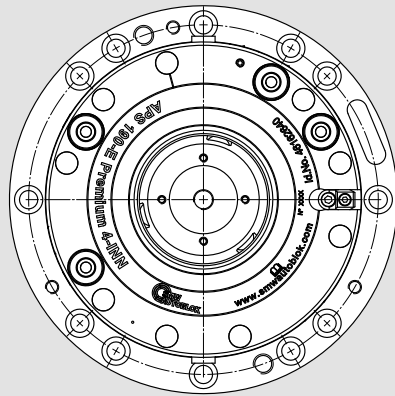
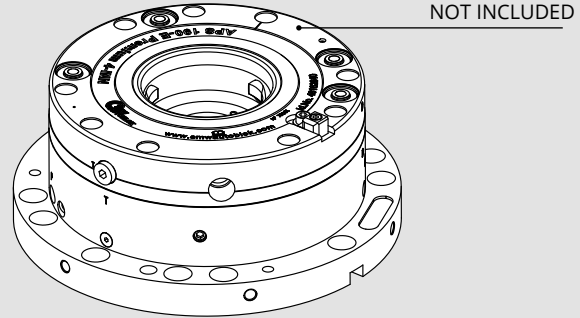
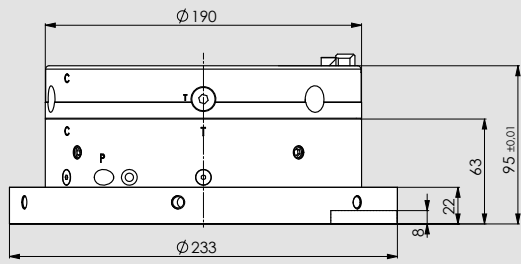

ID.N. (APS AND DISTRIBUTOR NOT INCLUDED)	HEIGHT	WEIGHT
46203000 MODULE HEIGHT EXTENSION GROUP N.6 FEEDINGS H95	95 mm	10,5 Kg

A APS open

T Air sensing / TURBO APS

The feedings **B C D E** are used on the pallet (ONE APS PALLET chapter) between pneumatics and hydraulics couplers put on the body of 190 APS (Id.n. 46162650). When on the pallet is mounted a TWIN VISE model STV or PT the feedings can be used in these different ways:

B TWIN VISE open

C TWIN VISE closed

D TWIN VISE Stroke control valve

E Air Sensing TWIN VISE or Driver pin Stroke control APS

The feeding **E** can not to be used on the pallet with the pneumatic / hydraulic coupler but can be used in another way to oversee the pneumatic stroke control of the APS 190; in this case the feeding is called **SC**.

Below a list of the possible configurations of the feedings:

Configuration feedings

SOLUTION TYPE	sol. n.	A open APS	T TURBO APS	T Air Sensing APS control	T MINITURBO +Air Sensing APS	T TURBO or Air sensing or MINITURBO/ Air sensing	E SC Stroke control APS	C Air sensing APS control	Number of feedings transferred on the pallet with the couplers
with n.2 feedings	1								
	2								
	3								
with n.4 feedings	1								2
	2								2
	3								2
	4								2
	5								3
	6								1
	7								
with n.6 feedings	1								4
	2								4
	3								4
	4								3
	5								2

CLAMPING UNIT FOR MULTIPLE APS WITHOUT INTEGRATED FEEDINGS ON MACHINE (FOR EXAMPLE 3 AXIS MACHINES)

1
FEEDING

2 APS 140 BASIC

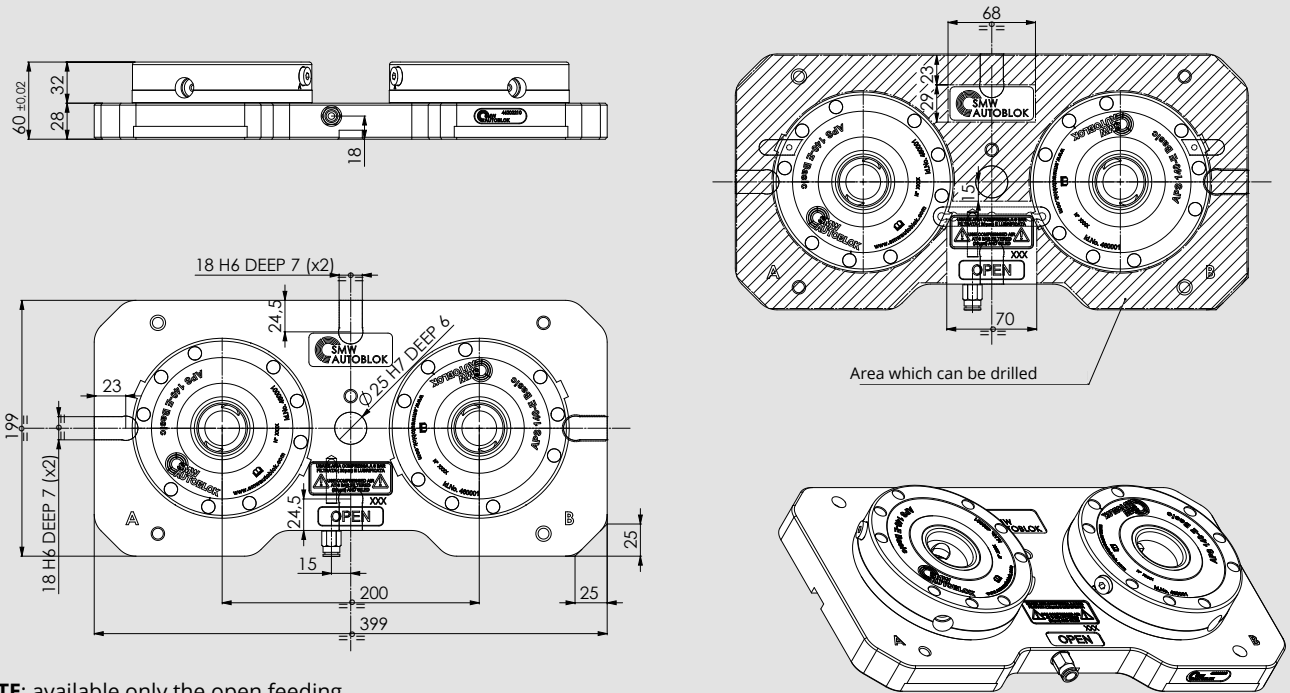

NOTE: available only the open feeding.

CLAMPING UNIT APS ID.No (APS included)
46202210 CLAMPING UNIT 2 APS140 BASIC

WEIGHT
21 Kg

4 APS 140 BASIC

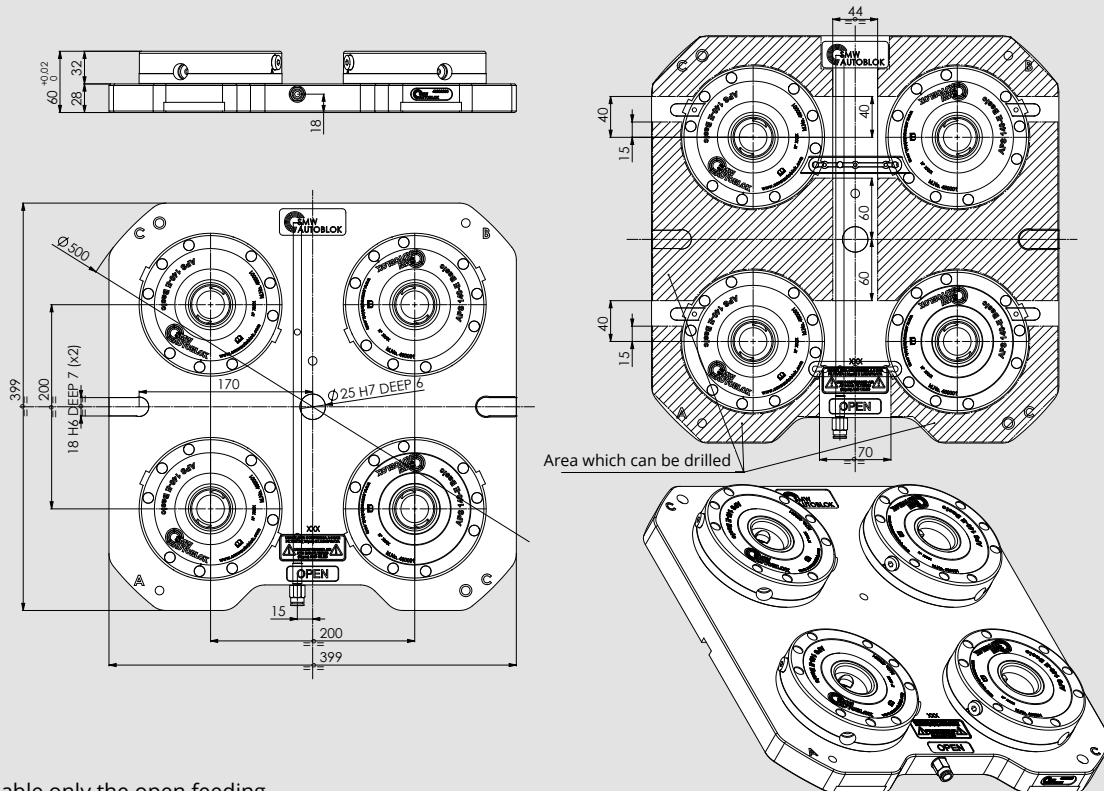

NOTE: available only the open feeding.

CLAMPING UNIT APS ID.No (APS included)
46202200 CLAMPING UNIT 4 APS140 BASIC

WEIGHT
42 Kg

2 FEEDINGS

CLAMPING UNIT FOR MULTIPLE APS WITHOUT INTEGRATED FEEDINGS ON MACHINE (FOR EXAMPLE 3 AXIS MACHINES)

2 APS 140 E PREMIUM LIGHT / BASIC

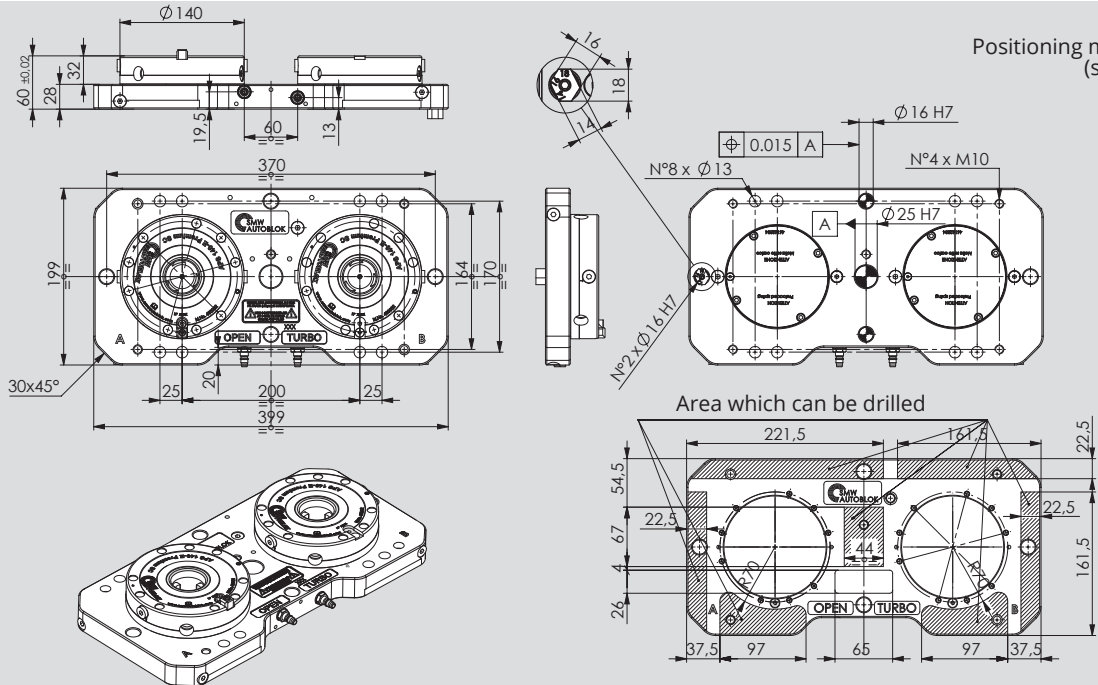

Optional:
Positioning multislot key
(see page 39)

2

NOTE: it's possible to order the PREMIUM configuration on request and with a surcharge. **NOTE 1:** available 2 feed.: OPEN and TURBO.

CLAMPING UNIT APS ID.N. (APS INCLUDED)	WEIGHT
460020 CLAMPING UNIT 2 APS140 E PREMIUM LIGHT 3 AXIS	21 Kg
460021 CLAMPING UNIT 2 APS140 E BASIC 3 AXIS	21 Kg

4 APS 140 E PREMIUM LIGHT / BASIC

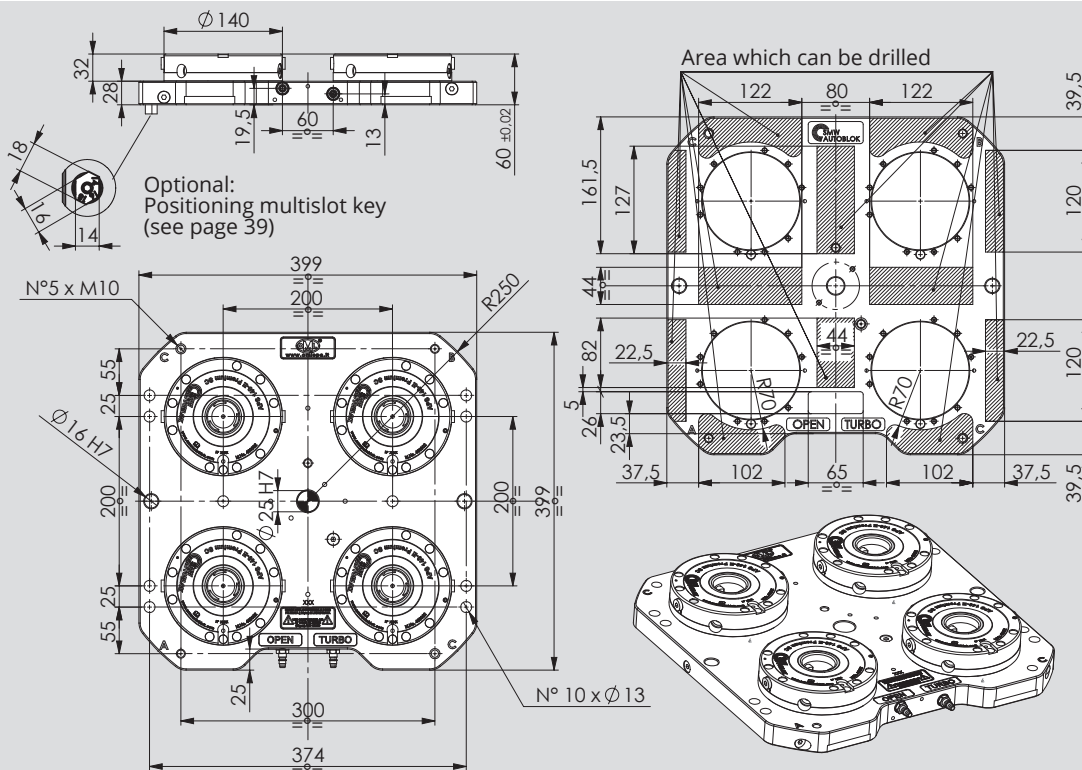

Optional:
Positioning multislot key
(see page 39)

NOTE: it's possible to order the PREMIUM configuration on request and with a surcharge. **NOTE 1:** available 2 feed.: OPEN and TURBO.

CLAMPING UNIT APS ID.N. (APS INCLUDED)	WEIGHT
460022 CLAMPING UNIT 4 APS140 E PREMIUM LIGHT 3 AXIS	41 Kg
460023 CLAMPING UNIT 4 APS140 E BASIC 3 AXIS	41 Kg

CLAMPING UNIT FOR MULTIPLE APS WITHOUT INTEGRATED FEEDINGS ON MACHINE (FOR EXAMPLE 3 AXIS MACHINES)

2
FEEDINGS

6 APS 140 E PREMIUM LIGHT / BASIC

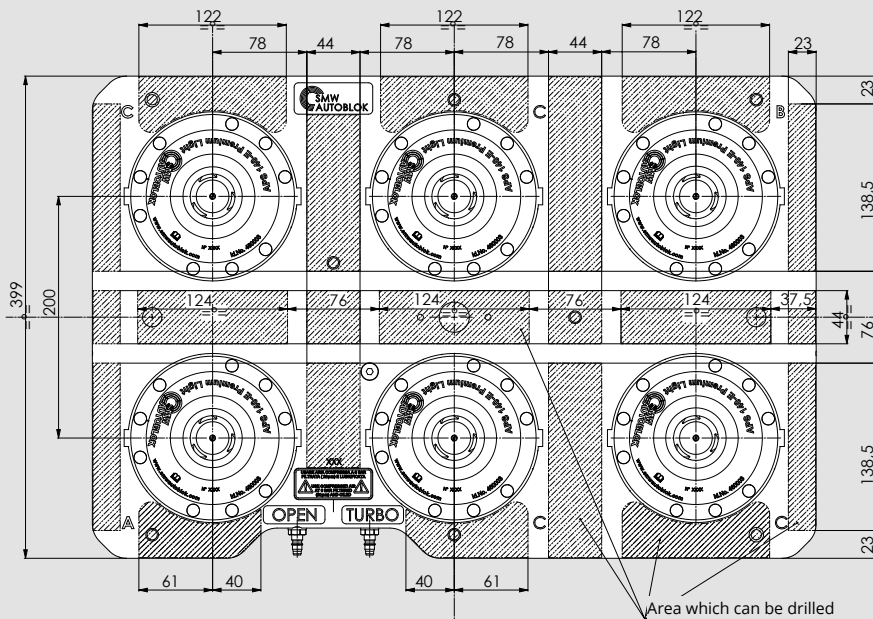
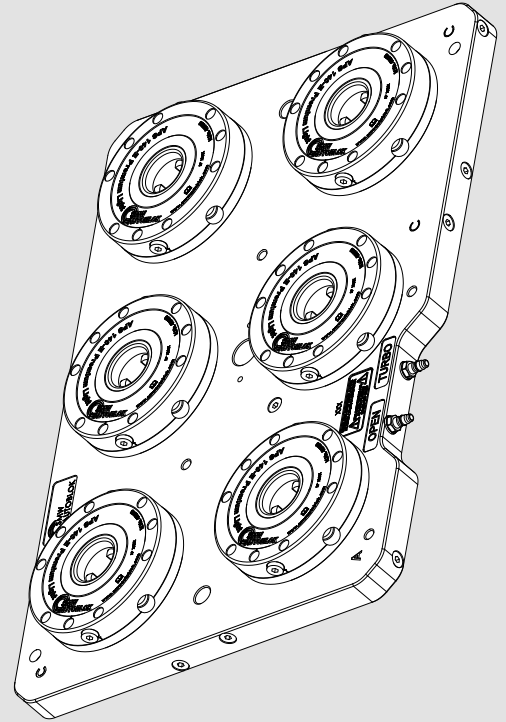
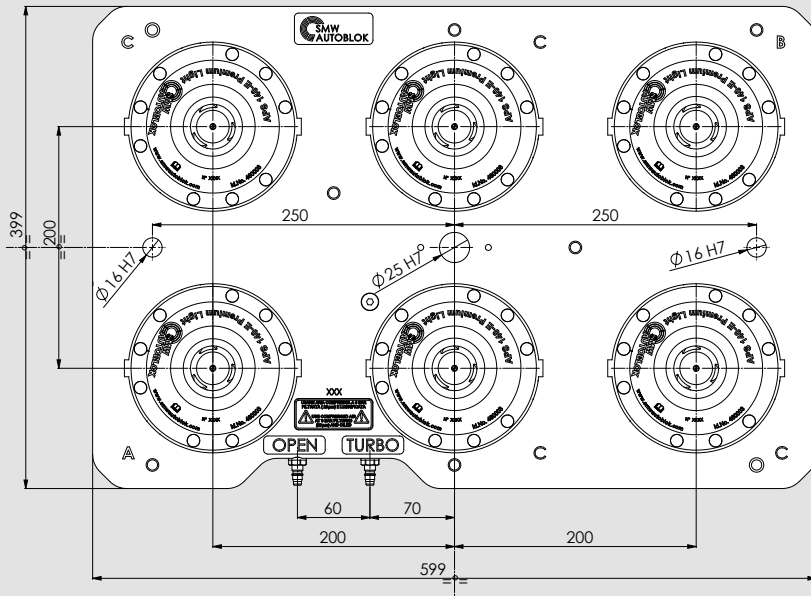
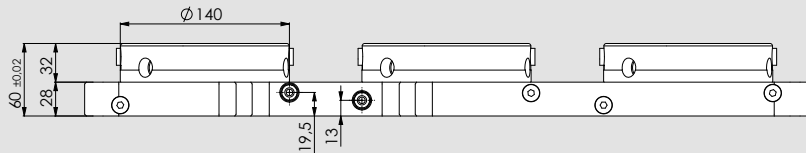

NOTE 1: available 2 feedings: OPEN and TURBO.

CLAMPING UNIT APS ID.No (APS included)	WEIGHT
46186672 CLAMPING UNIT 6 APS140 E BASIC	64 Kg
46186674 CLAMPING UNIT 6 APS140 E PREMIUM LIGHT	64 Kg

3 FEEDINGS

CLAMPING UNIT FOR MULTIPLE APS WITHOUT INTEGRATED FEEDINGS ON MACHINE (FOR EXAMPLE 3 AXIS MACHINES)

2 APS 140 E PREMIUM LIGHT SC

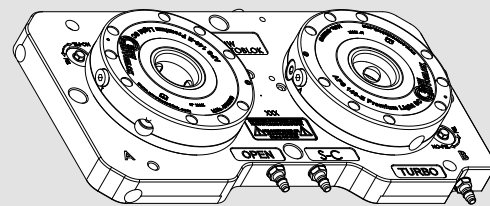
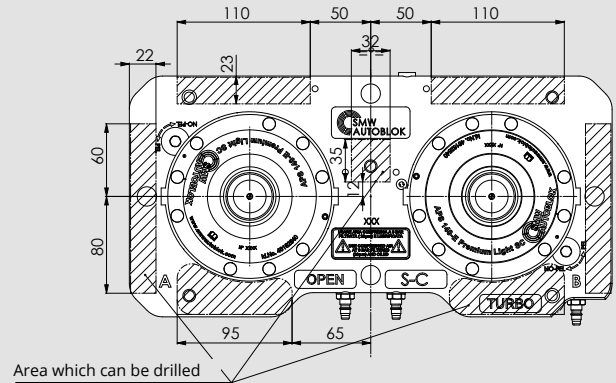
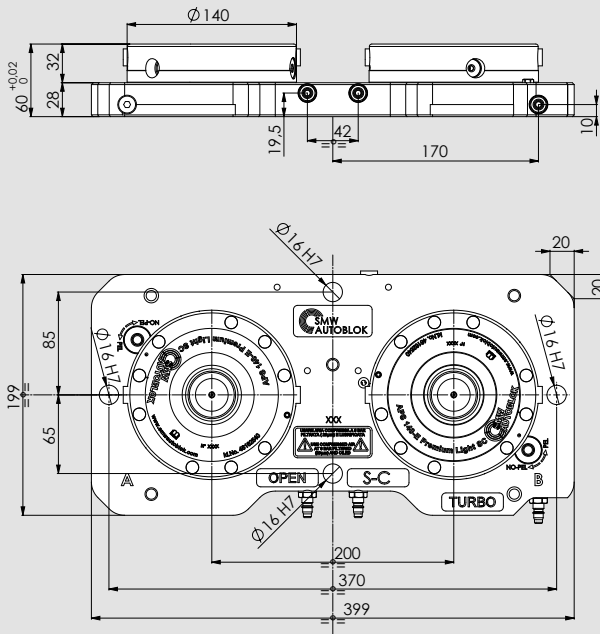

NOTE 1: available 3 feedings: OPEN, STROKE CONTROL SC and TURBO/AIR SENSING.

NOTE 2: when the Air sensing is not used, it's possible to exclude it thanks to two selectors placed on the front plate.

CLAMPING UNIT APS ID.No (APS included)	WEIGHT
46202230 CLAMPING UNIT 2 APS140 E PREMIUM LIGHT SC	21 Kg

4 APS 140 E PREMIUM LIGHT SC

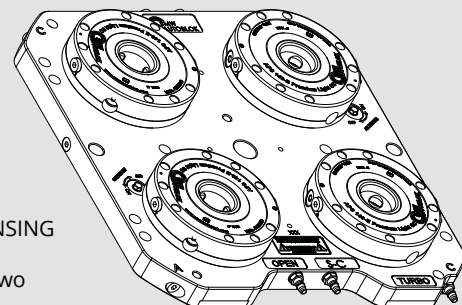
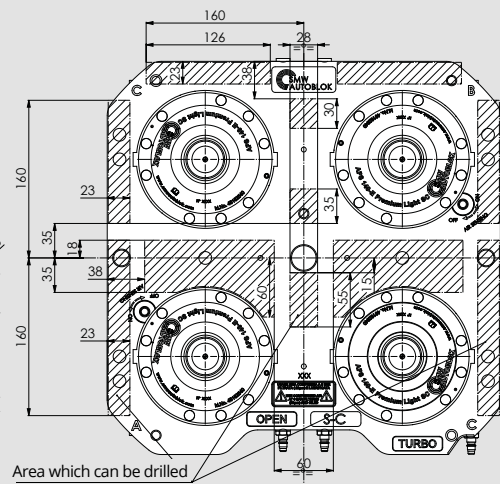
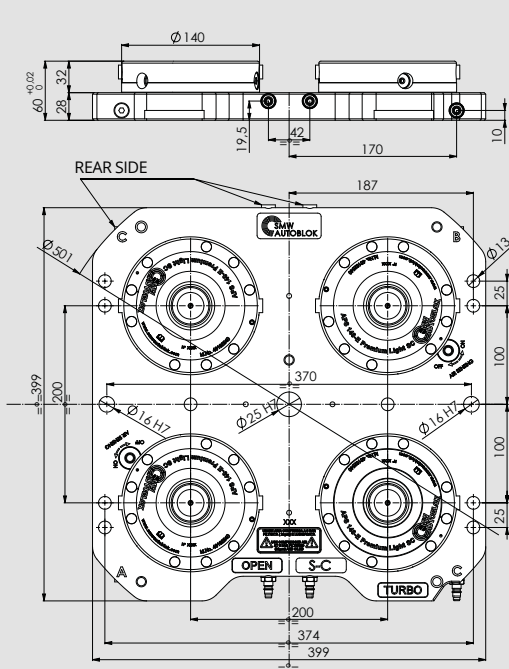

NOTE 1: available 3 feedings: OPEN, STROKE CONTROL SC and TURBO/AIR SENSING (it is possible to load also on rear side).

NOTE 2: when the Air sensing is not used, it's possible to exclude it thanks to two selectors placed on the front plate.

CLAMPING UNIT APS ID.No (APS included)	WEIGHT
46202220 CLAMPING UNIT 4 APS140 E PREMIUM LIGHT SC	41 Kg

MEDIA FEED WITHOUT INTEGRATED MACHINE FEEDINGS (f.e. 3 axis machines) for plate with 2 APS 140 E

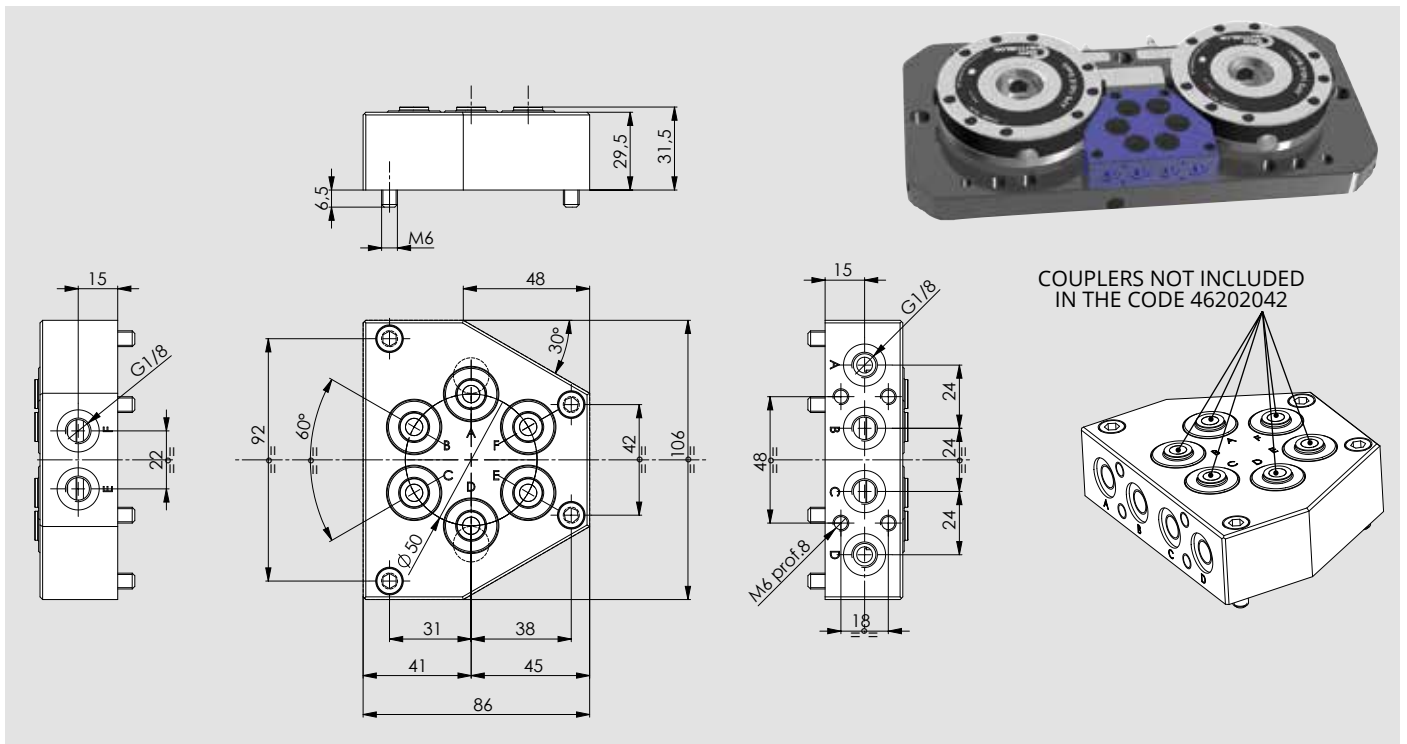

ID.N. MEDIA FEED PREPARED FOR N. 6 COUPLERS	POSSIBLE FEEDINGS	WEIGHT
46202042 MEDIA FEED PREPARED FOR N.6 MALE COUPLERS	A-B-C-D-E-F	1,6 Kg
71718106 MALE COUPLER	-	0.030 kg

MEDIA FEED WITHOUT INTEGRATED MACHINE FEEDINGS (f.e. 3 axis machines) for plate with 4 APS 140 E

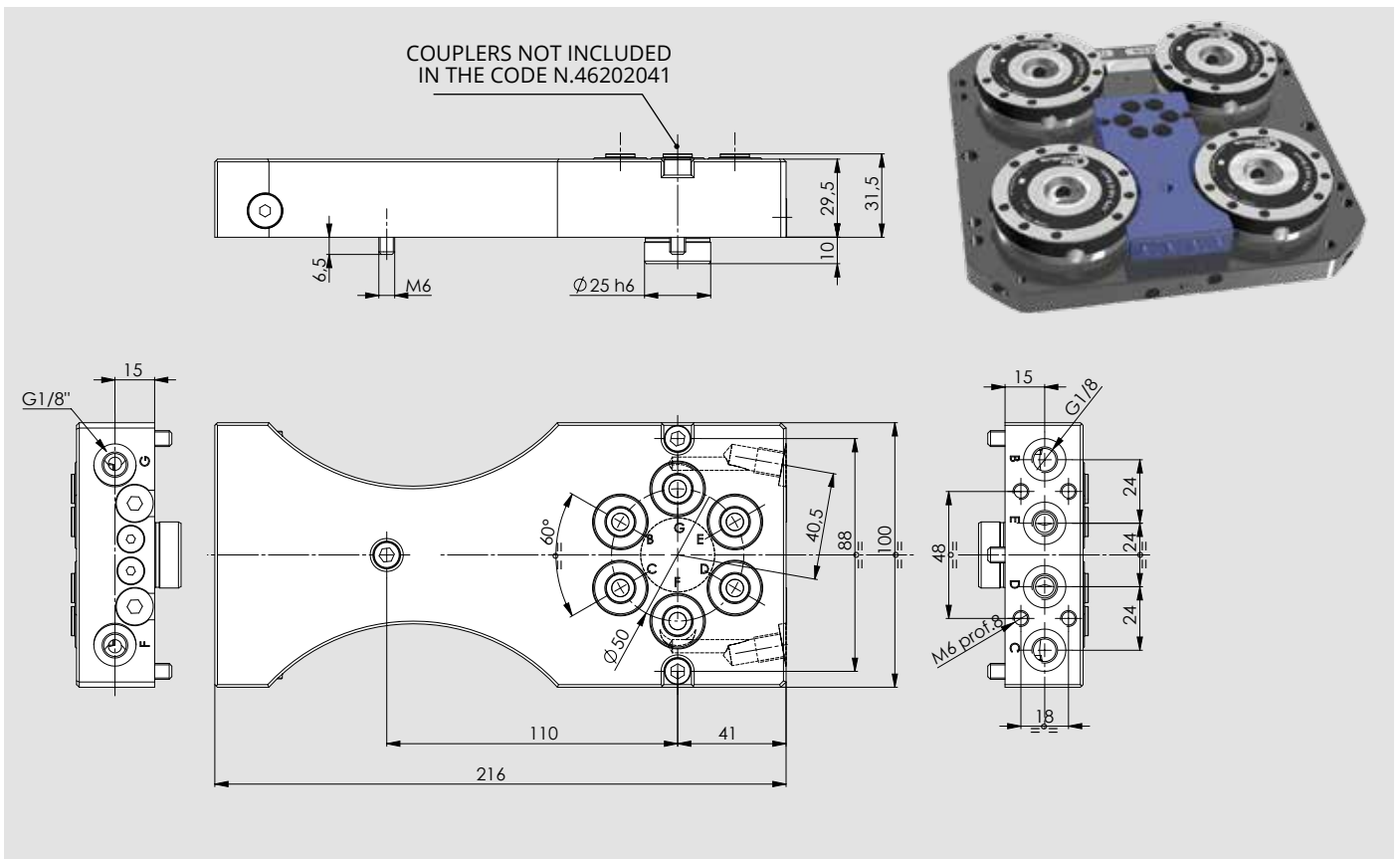

ID.N. MEDIA FEED PREPARED FOR MAXIMUM N.6 COUPLERS	POSSIBLE FEEDINGS	WEIGHT
46202041 MEDIA FEED PREPARED FOR N.6 MALE COUPLERS	B-C-D-E-E-F-G	1,6 Kg
71718106 MALE COUPLER	-	0.030 kg

MULTISLOT KEY optional

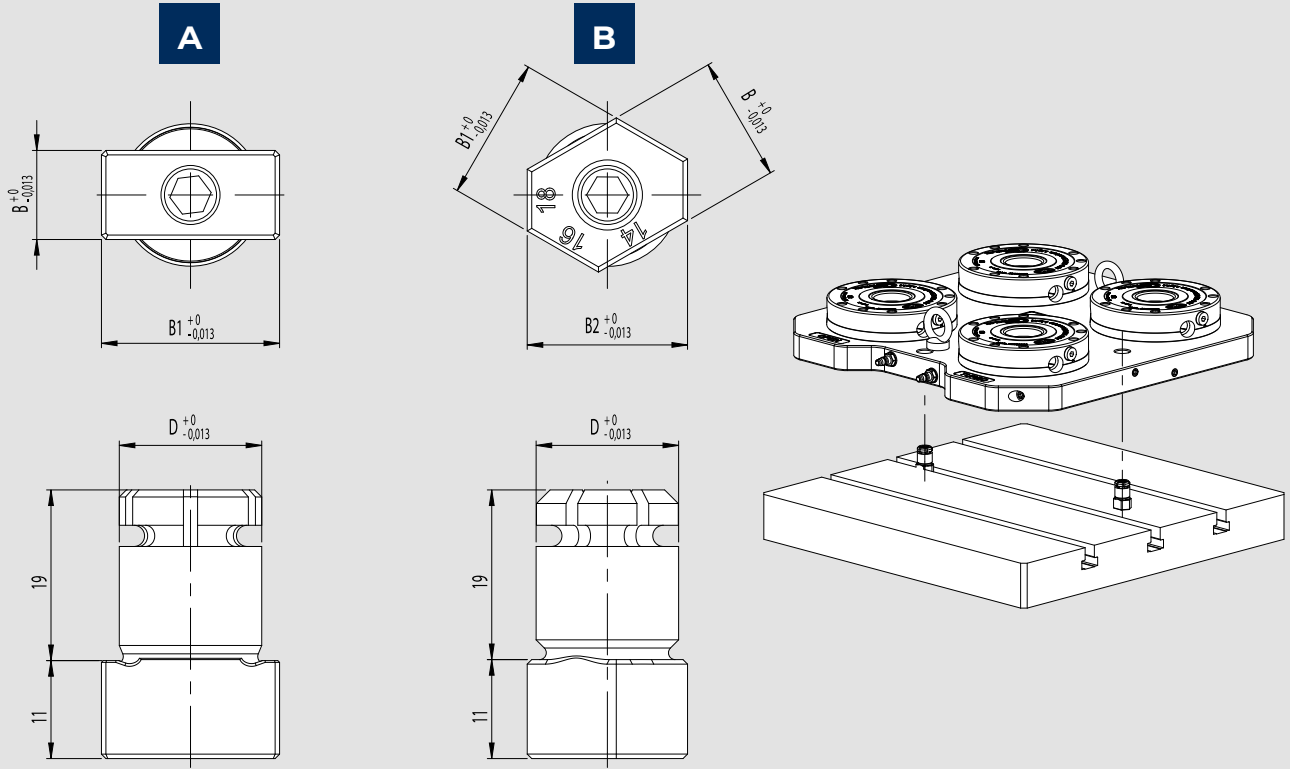

	ID.No.	D mm	B mm	B1 mm	B2 mm	Ø mm
A	71290181 MULTISLOT OPTIONAL KEY	16	12	22	-	16.01±0.01
B	71290182 MULTISLOT OPTIONAL KEY	16	14	16	18	16.01±0.01
A	71290183 MULTISLOT OPTIONAL KEY	16	10	20	-	16.01±0.01
B	71290184 MULTISLOT OPTIONAL KEY	20	24	28	32	20.01±0.01

CLAMPING UNIT FOR AUTOMATION WITH 4 APS 140 AND FEEDINGS FOR 5 AXIS possible configuration scheme for 5 axis machines 2-4-6 FEEDINGS

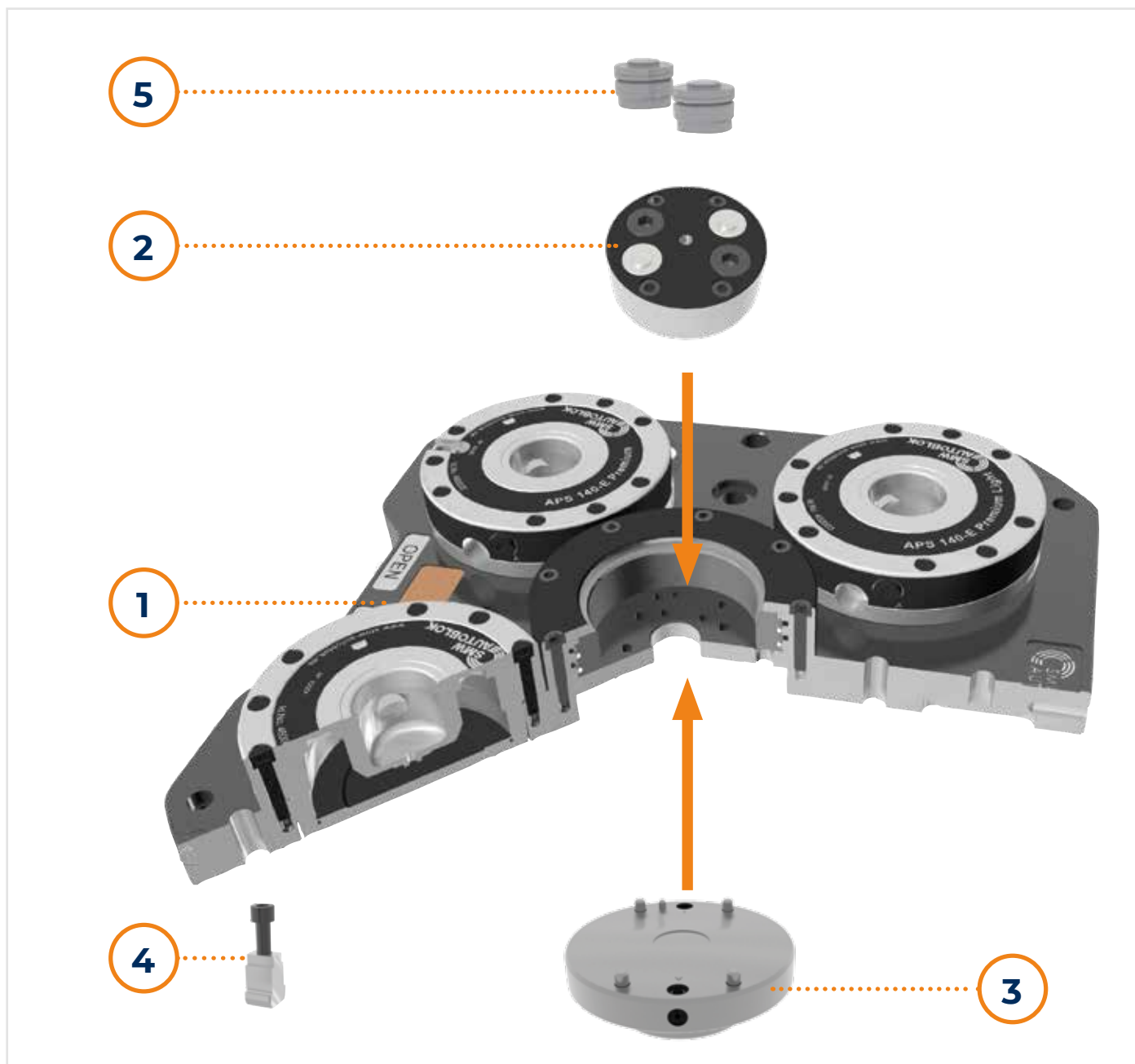

CLAMPING UNIT COMPOSITION		2 FEEDINGS		4 FEEDINGS		6 FEEDINGS	
		ID.No.	Q.TY	ID.No.	Q.TY	ID.No.	Q.TY
1	CLAMPING UNIT with 4 APS 140	46202000	1	46202000	1	46202000	1
2	MEDIA FEED	Cover supplied***	-	46202026***	1	46202026***	1
3	DISTRIBUTOR**	CUSTOMIZED	1	CUSTOMIZED	1	CUSTOMIZED	1
4	T-NUTS SET	to choose according to the T-Slot	1	to choose according to the T-Slot	1	to choose according to the T-Slot	1
5	MALE COUPLER*	-	-	71718106	2	71718106	4

* MALE COUPLER: the ID.n. refers to a single piece

** CUSTOMIZED DISTRIBUTOR EXAMPLE: to be designed specifically for each machine until to 6 feedings

*** To use the Media Feed 46202026 it's necessary to remove the supplied central cover supplied.

ATTENTION: the pneumatic system of the pressure switch must signal the alarm condition and must prevent the pallet exchange on the APS or any robot operation when the inlet pressure is less than 6 bar.

3

ROTARY PLATE Quick Change System

47

MANUAL OPERATION

APS modules

Ø202 - 260 - 330 - 420 - 520 - 650 - 1000 - 1400

65

AUTOMATIC OPERATION

APS modules

Ø202 - 260 - 330 - 420 - 520 - 650

75

AUTOMATIC OPERATION+3

APS module + 3 FEEDINGS PNEUMATIC

Ø202 - 260 - 330 - 420 - 520 - 650

85

ACCESSORIES

3 or 4 PNEUMATIC Feedings ROTATING
MANIFOLD

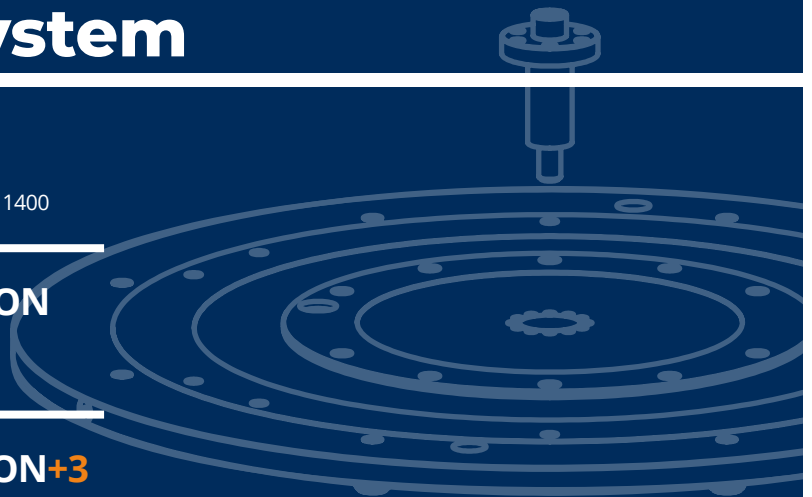

3

ROTARY PLATE

Pallet/Tooling fast set-up on turning spindles

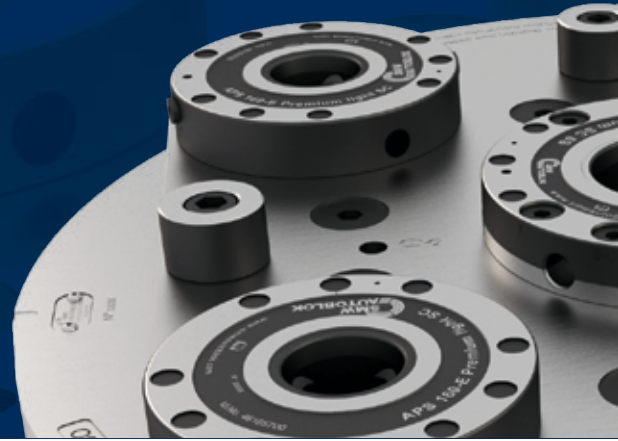

▶ **CHUCK**

▶ **PALLET**

▶ **ROTARY PLATE**

▶ **ADAPTOR**



ROTARY PLATE

Rotating table which holds the workpiece in place during operations

CUSTOMER BENEFITS

- PALLET/TOOLING FAST SET-UP
- CHUCKS FAST SET-UP ON TURNING SPINDLES, MANUAL CONNECTION (WITH SCREW) BETWEEN CHUCK AND CYLINDER FOR MANUAL ROTARY PLATE
- TOOLING PRESENCE WITH AIR SENSING FUNCTION FOR AUTOMATIC ROTARY PLATE
- SC STROKE CONTROL FUNCTION
- POSITIONING ACCURACY < 0,005 mm
- 3 PNEUMATIC FEEDINGS (6 BAR) AVAILABLE ON PALLET FOR AUTOMATIC ROTARY PLATE+3FEEDINGS

TECHNICAL FEATURES

- CASE HARDENED MAIN COMPONENTS TO ASSURE BETTER ACCURACY AND LONG OPERATING LIFE
- PNEUMATIC OPENING
- CLOSING BY SPRING + TURBO FUNCTION
- OPENING/CLOSING APS MANUALLY OPERATED
- OPENING/CLOSING APS AUTOMATICALLY OPERATED
- G6.3 BALANCING DEGREE

Types	Size								Manual operation of APS modules	Automatic operation of APS modules	Automatic operation of APS modules + 3 feedings	APS central size		APS lateral size		Ø pallets and chucks usable on rotary plate
	202	260	330	420	520	650	1000	1400				190	250	140	160	
MANUAL ROTARY PLATE	202											1				170-210
		260											1			210-250-315
			330											3		250-315
				420										4		400
					520							1			4	500-650
						650						1			4	650-800
							1000						1		6	1000-1250
AUTOMATIC ROTARY PLATE								1400				1		8	1400-1600-1800	
	202											1			170-210	
		260											1		210-250-315	
			330											3	250-315	
				420										4	400	
					520							1			4	500
						650						1			4	650-800
AUTOMATIC ROTARY PLATE + 3 FEEDINGS	202											1			170-210	
		260											1		210-250-315	
			330											3	250-315	
				420										4	400	
					520							1			4	500
						650						1			4	650-800

Drawings and data are subject to change by SMW-Autoblok.

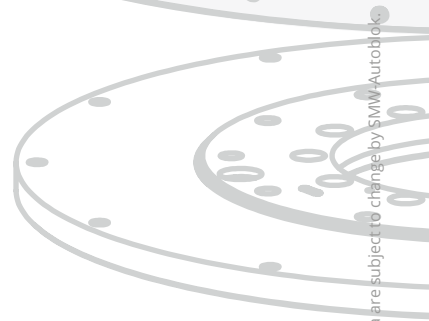
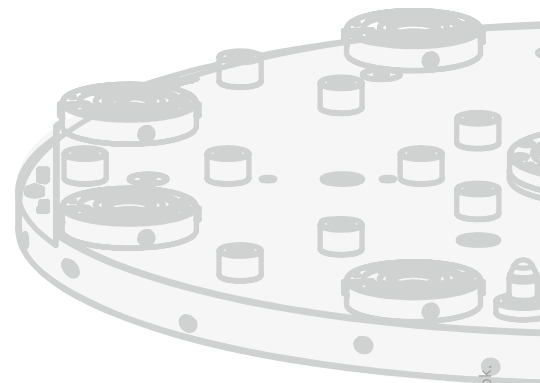
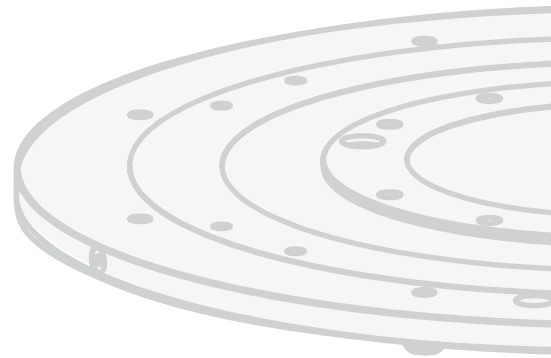
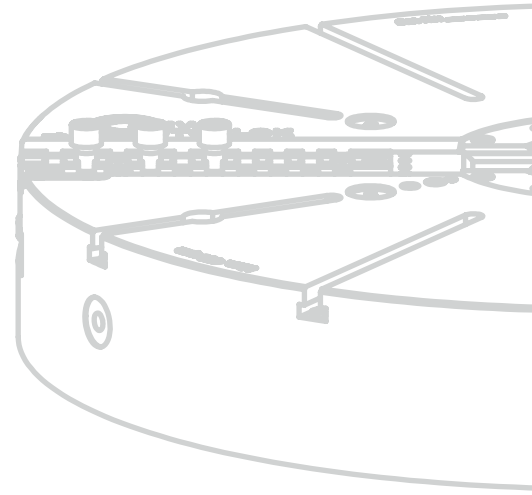

Drawings and data are subject to change by SMW-Autoblok.

MANUAL OPERATION

APS MODULES

3
a



Drawings and data are subject to change by SMW-Autoblok.

ROTARY PLATE $\varnothing 202$

with APS 190 manual operation

Manual tooling fast set-up for $\varnothing 170$ and $\varnothing 210$ pallets and chucks



N. 2 PNEUMATIC CONNECTIONS FOR MANUAL OPENING AND TURBO COMMAND

Applications/Customer Benefits

- Pallet/Tooling fast set-up
- Chucks fast set-up $\varnothing 170$ and $\varnothing 210$ on turning spindles, manual connection (with screw) between chuck and cylinder
- Positioning accuracy < 0,005 mm

Technical features

- Case hardened main components to assure better accuracy and long operating life
- Pneumatic opening (OPEN)
- Closing by spring + Turbo function
- Opening/closing manually operated
- G6.3 balancing degree

ROTARY PLATE MODEL	ID.NO.	REPEATABILITY	CLAMPING FORCE BY TURBO FUNCTION AT 6 bar	MAX PRESSURE OPENING / CLOSING	WEIGHT Kg	CHUCK FEATURES			
						DRAW BAR MAX PULLING FORCE	DRAW BAR MAX PUSHING FORCE	$\varnothing 170$ CHUCK MAX RPM (*)	$\varnothing 210$ CHUCK MAX RPM (**)
$\varnothing 202$ MANUAL	46220450	0,005 mm	45 kN	6 bar	16	40 kN	20 kN	4500	3500

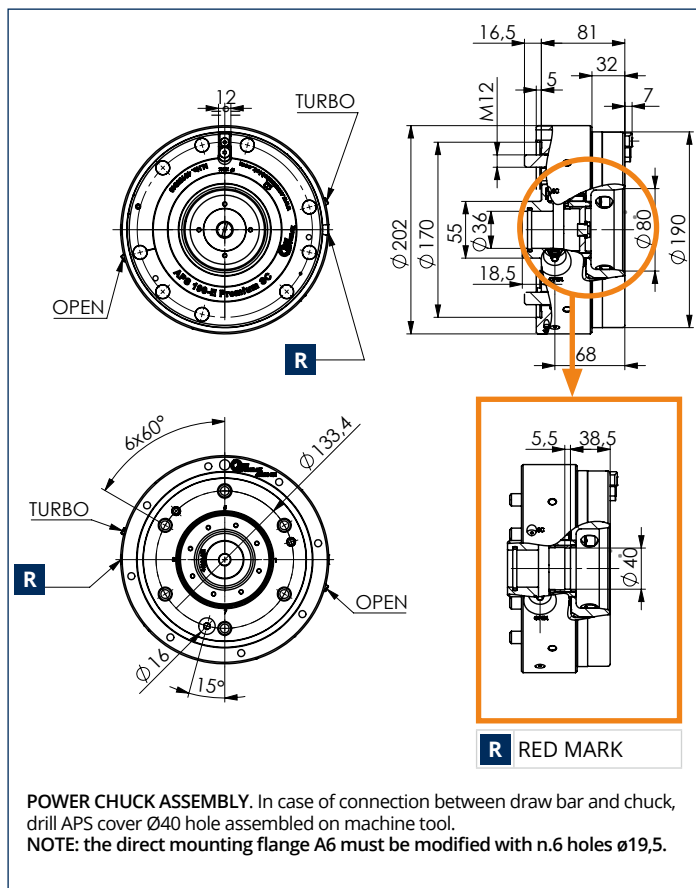

Weight/Speed diagram

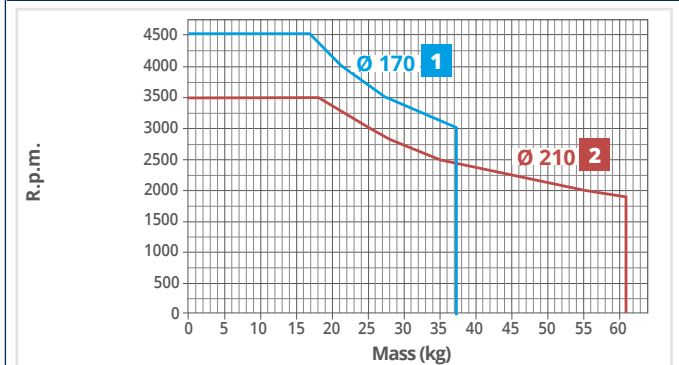

- (*) Diagram is showing the rpm speed depending from:
 - total max weight on rotary plate (pallet + chuck or fixture + workpiece).
 - max overall dimension on rotary plate $\varnothing 170$ and 190 mm total length
- (**) Diagram is showing the rpm speed depending from:
 - total max weight on rotary plate (pallet + chuck or fixture + workpiece).
 - max overall dimension on rotary plate $\varnothing 210$ and 220 mm total length

(*) (**) rpm max speed has to be reduced if used chuck type has lower rpm speed.

ROTARY PLATE Ø202: AVAILABLE PALLETS

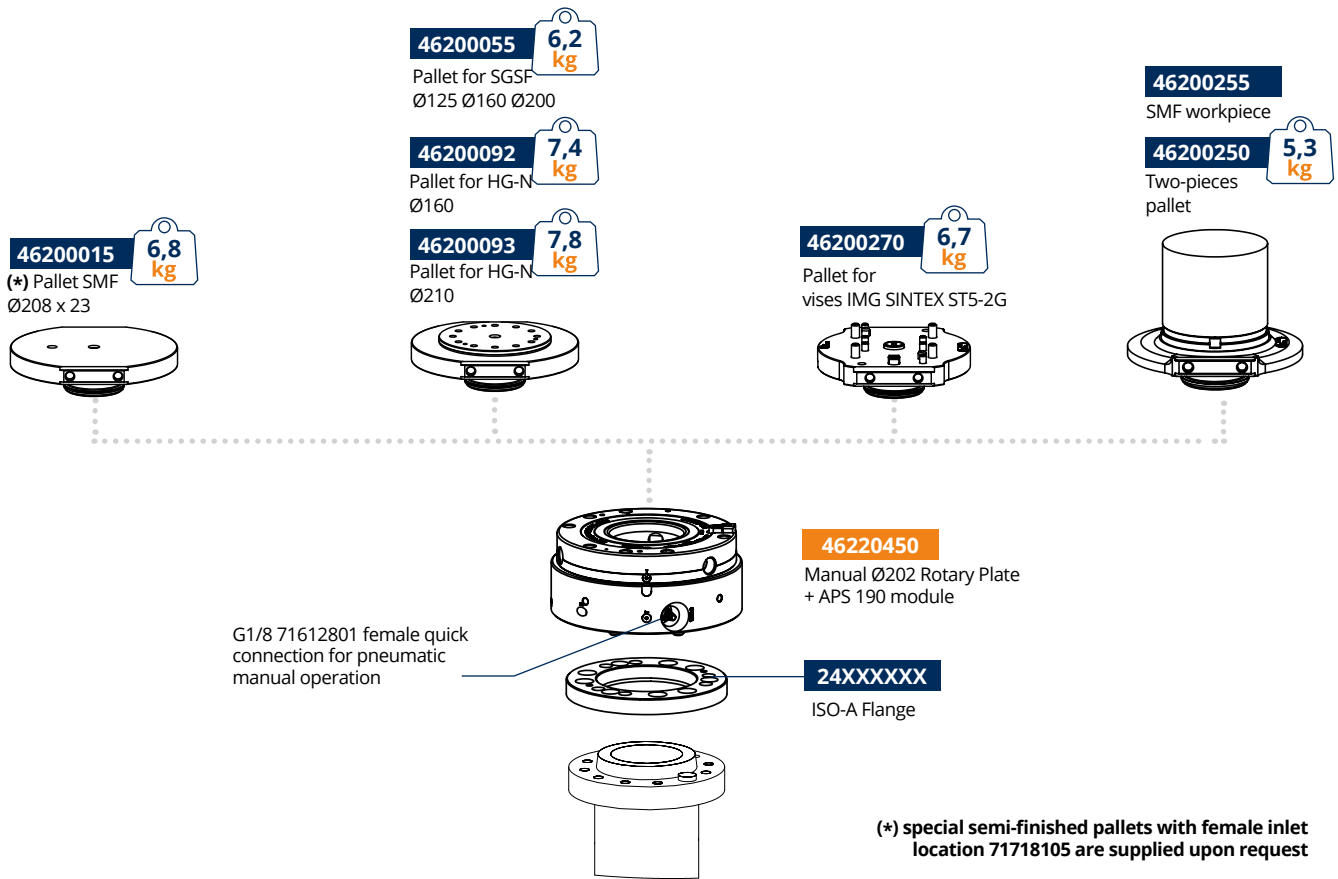

ROTARY PLATE Ø202: USABLE CHUCKS SCHEME

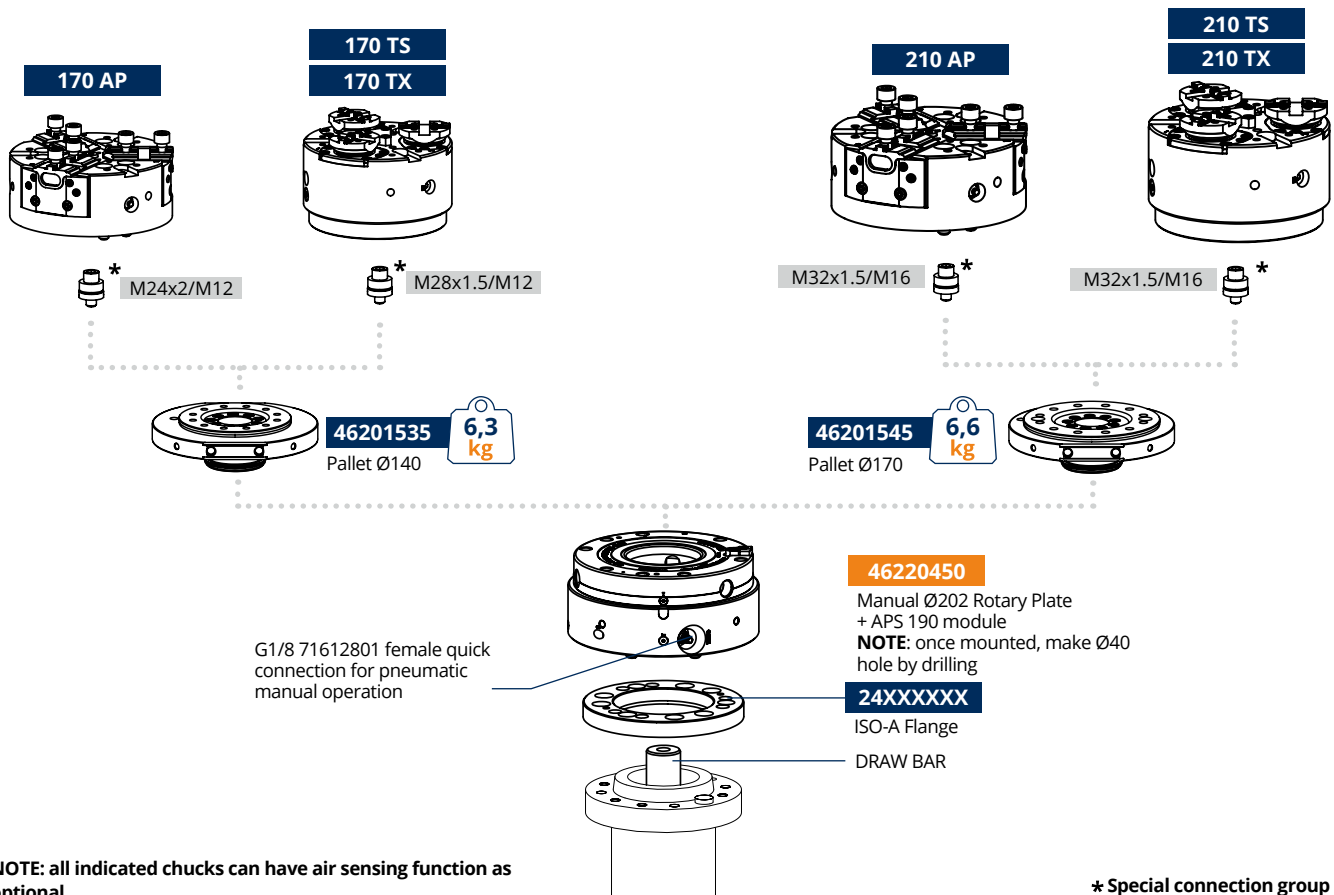

ROTARY PLATE Ø260

with APS 250 manual operation

Manual tooling fast set-up for Ø 210-250 and Ø 315 pallets and chucks



N. 2 PNEUMATIC CONNECTIONS FOR MANUAL OPENING AND TURBO COMMAND

Applications/Customer Benefits

- Pallet/Tooling fast set-up
- Chucks fast set-up Ø210 Ø250 and Ø315 on turning spindles, manual connection (with screw) between chuck and cylinder
- Positioning accuracy < 0,005 mm

Technical features

- Case hardened main components to assure better accuracy and long operating life
- Pneumatic opening (OPEN)
- Closing by spring + Turbo function
- Opening/closing manually operated
- G6.3 balancing degree

ROTARY PLATE MODEL	ID.NO.	REPEATABILITY	CLAMPING FORCE BY TURBO FUNCTION AT 6 bar	MAX PRESSURE OPENING / CLOSING	WEIGHT Kg	CHUCK FEATURES				
						DRAW BAR MAX PULLING FORCE	DRAW BAR MAX PUSHING FORCE	Ø210 CHUCK MAX RPM (*)	Ø250 CHUCK MAX RPM (**)	Ø315 CHUCK MAX RPM (***)
Ø260 MANUAL	46220490	0,005 mm	55 kN	6 bar	28	50 kN	30 kN	4000	3000	2000

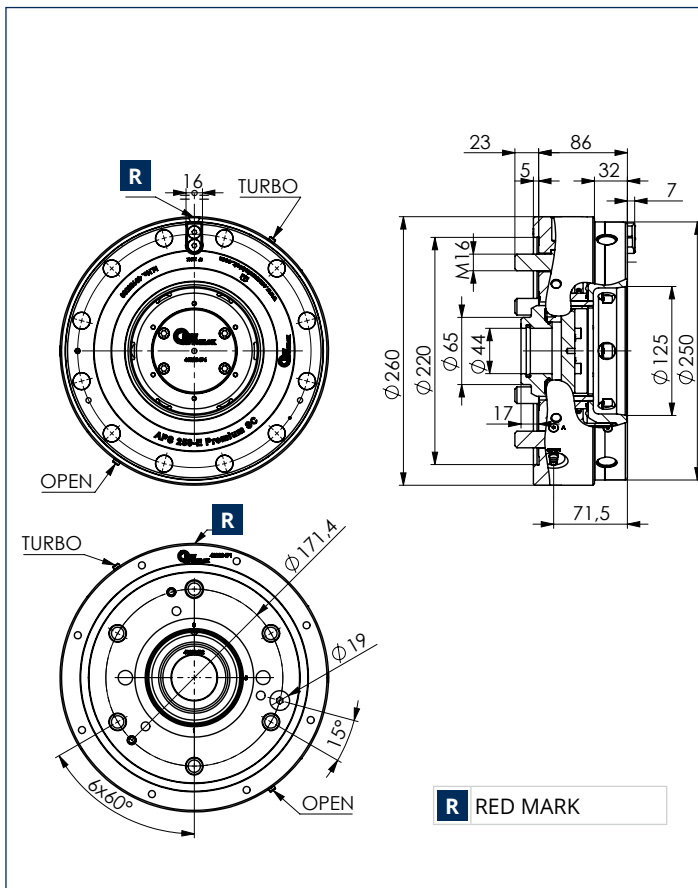

Weight/Speed diagram

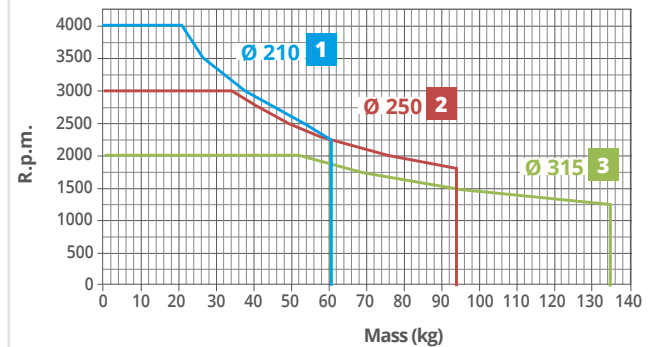

- 1 (*) Diagram is showing the rpm speed depending from:
 - total max weight on rotary plate (pallet + chuck or fixture + workpiece).
 - max overall dimension on rotary plate Ø210 and 220 mm total length
- 2 (**) Diagram is showing the rpm speed depending from:
 - total max weight on rotary plate (pallet + chuck or fixture + workpiece).
 - max overall dimension on rotary plate Ø250 and 250 mm total length
- 3 (***) Diagram is showing the rpm speed depending from:
 - total max weight on rotary plate (pallet + chuck or fixture + workpiece).
 - max overall dimension on rotary plate Ø315 and 250 mm total length

(*) (**) (***) rpm max speed has to be reduced if used chuck type has lower rpm speed

ROTARY PLATE Ø260: AVAILABLE PALLETS

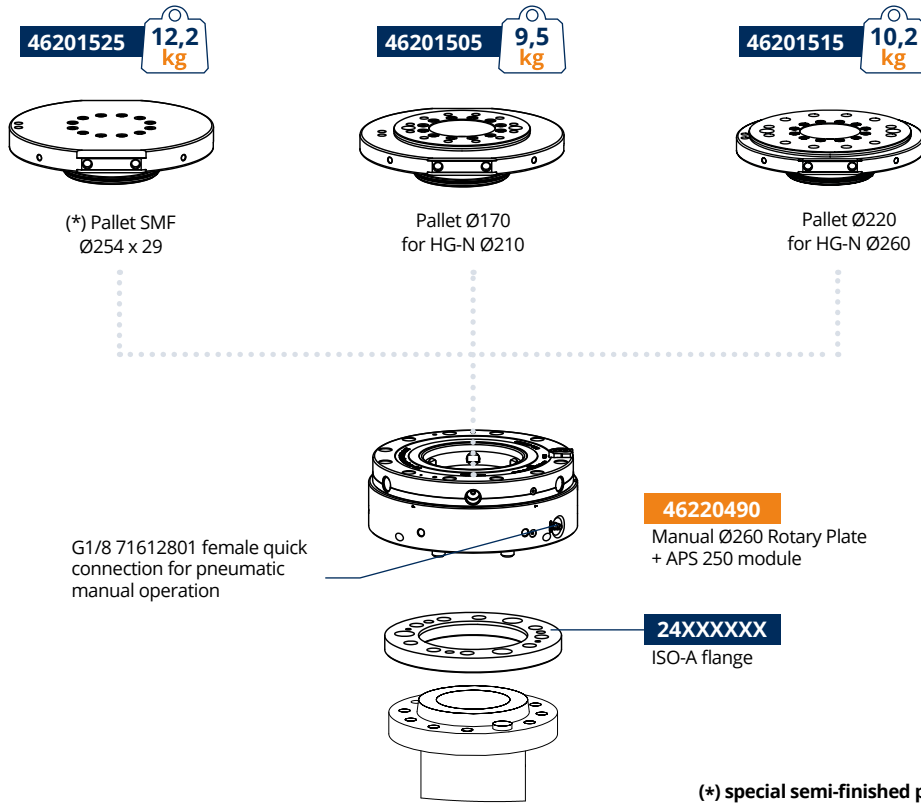

(*) special semi-finished pallets with female inlet location 71718105 are supplied upon request

ROTARY PLATE Ø260: USABLE CHUCKS SCHEME

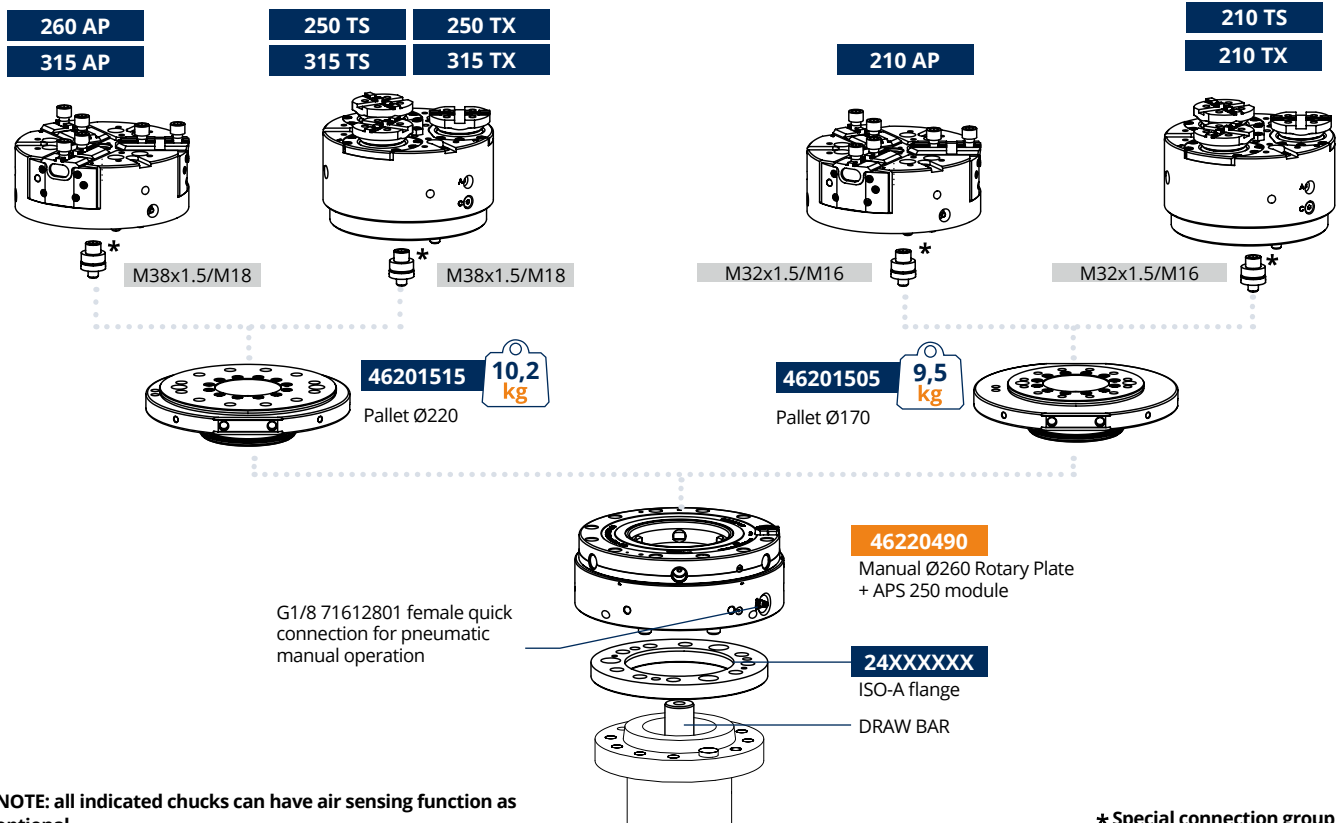

NOTE: all indicated chucks can have air sensing function as optional

* Special connection group

ROTARY PLATE Ø330: AVAILABLE PALLETS

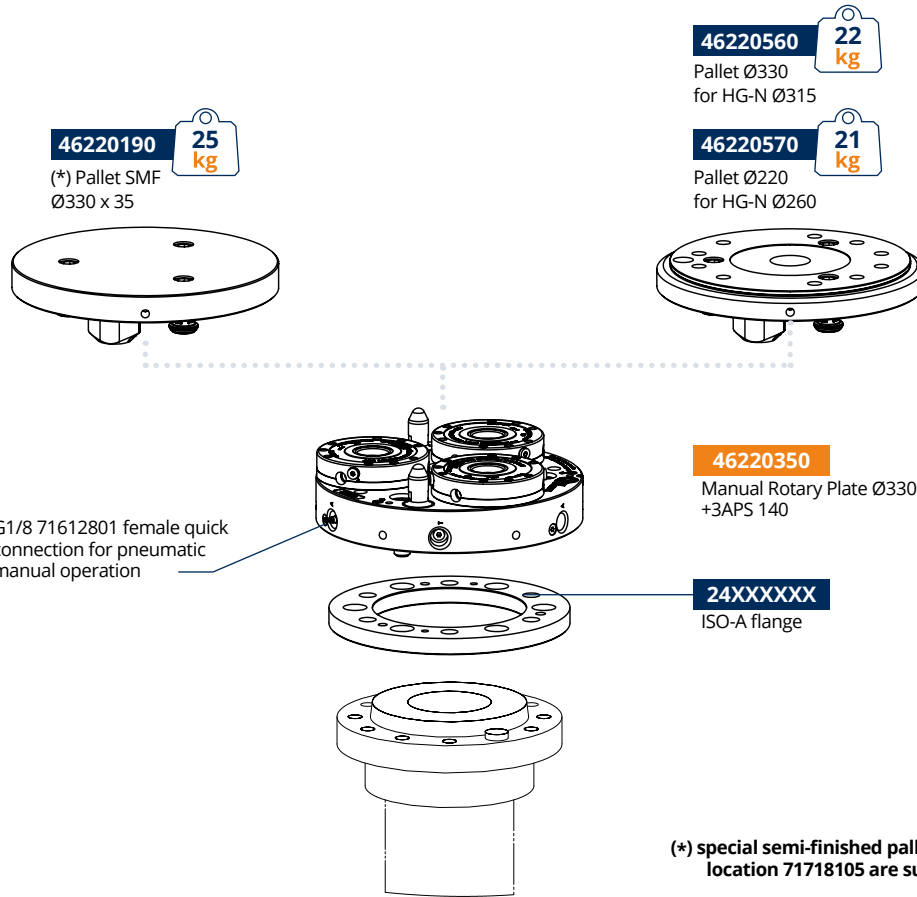

ROTARY PLATE Ø330: USABLE CHUCKS SCHEME

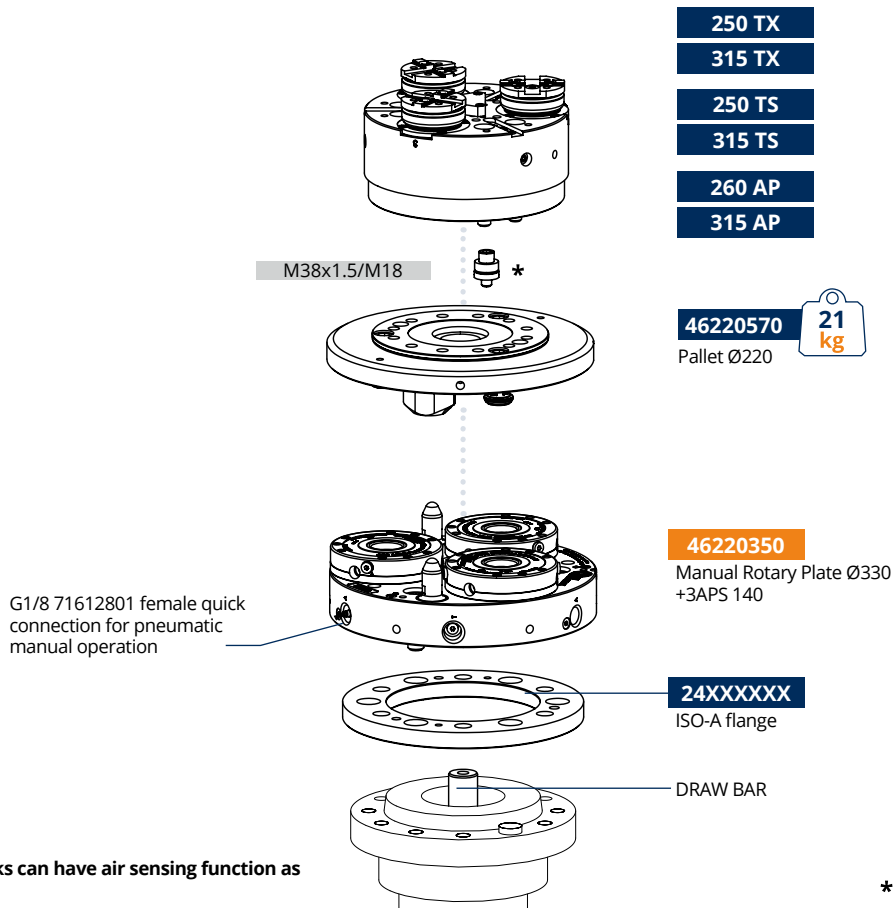

ROTARY PLATE Ø420: AVAILABLE PALLETS

46220200

40 kg

(*) Pallet SMF
Ø420 x 35

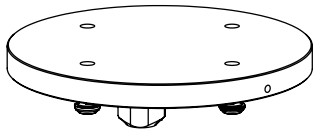

46220550

31 kg

Pallet Ø300
for HG-N Ø315

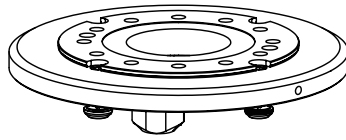

46220540

33 kg

Pallet Ø380
for HG-N Ø400

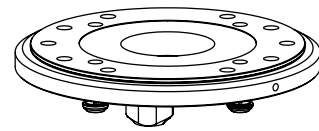

G1/8 71612801 female quick connection for pneumatic manual operation

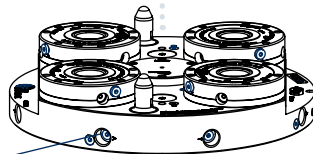

46220390

Manual Ø420 Rotary Plate
+ 4APS 140 module

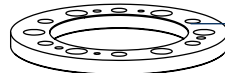

24XXXXXX

ISO-A flange

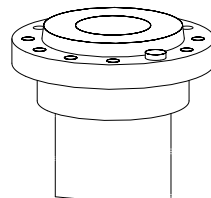

(*) special semi-finished pallets with female inlet location 71718105 are supplied upon request

ROTARY PLATE Ø420: USABLE CHUCKS SCHEME

400 TS

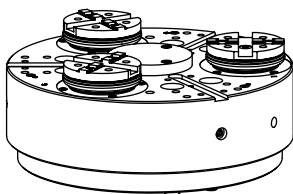

M60x1.5/M24



400 AP

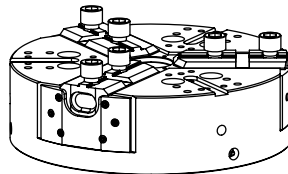

M60x1.5/M24



400 TX

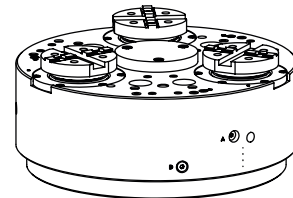

M60x1.5/M24

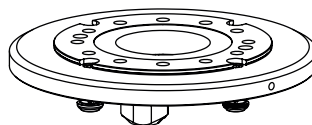

46220550

31 kg

Pallet Ø300

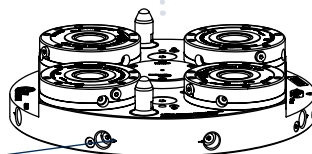

46220390

Manual Ø420 Rotary Plate
+ 4APS 140 module

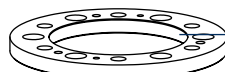

24XXXXXX

ISO-A flange

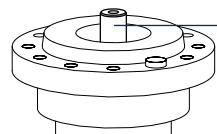

DRAW BAR

G1/8 71612801 female quick connection for pneumatic manual operation

NOTE: all indicated chucks can have air sensing function as optional

* Special connection group

ROTARY PLATE Ø520

with APS 190 and 4 APS 160 manual operation

Manual tooling fast set-up for Ø 500 and Ø 650 pallets and chucks

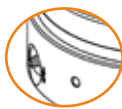

N. 2 PNEUMATIC CONNECTIONS FOR MANUAL OPENING AND TURBO COMMAND

Applications/Customer Benefits

- Pallet/Tooling fast set-up
- Chucks fast set-up Ø500 and Ø650 on turning spindles, manual connection (with screw) between chuck and cylinder
- Positioning accuracy < 0,005 mm

Technical features

- Case hardened main components to assure better accuracy and long operating life
- Pneumatic opening (OPEN)
- Closing by spring + Turbo function
- Opening/closing manually operated
- G6.3 balancing degree

ROTARY PLATE MODEL	ID.NO.	REPEATABILITY	CLAMPING FORCE BY TURBO FUNCTION AT 6 bar	MAX PRESSURE OPENING / CLOSING	WEIGHT Kg	CHUCK FEATURES			
						DRAW BAR MAX PULLING FORCE	DRAW BAR MAX PUSHING FORCE	Ø500 CHUCK MAX RPM (*)	Ø650 CHUCK MAX RPM (**)
Ø520 MANUAL	46220010	0,005 mm	165 kN	6 bar	113	100 kN	60 kN	1500	1000

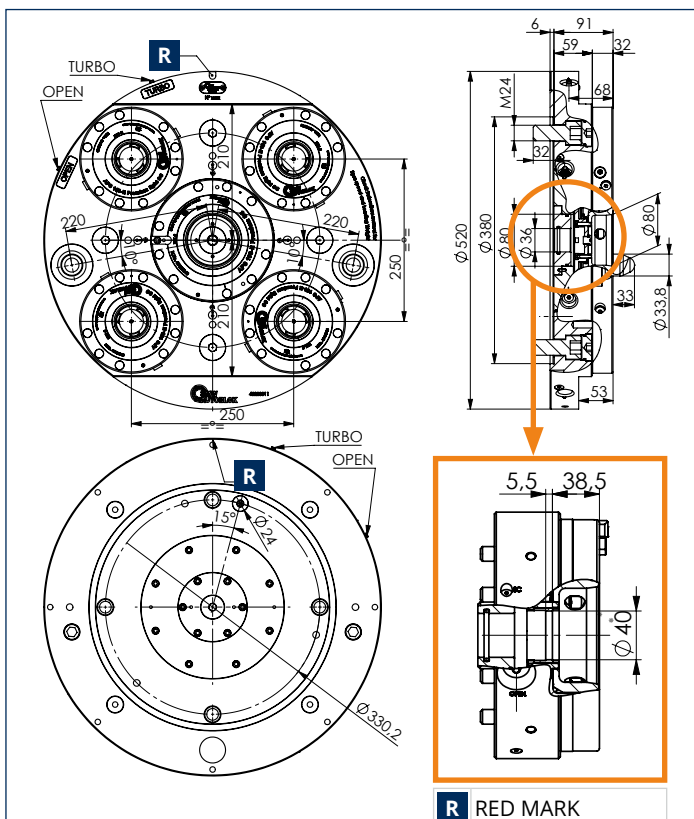

Weight/Speed diagram

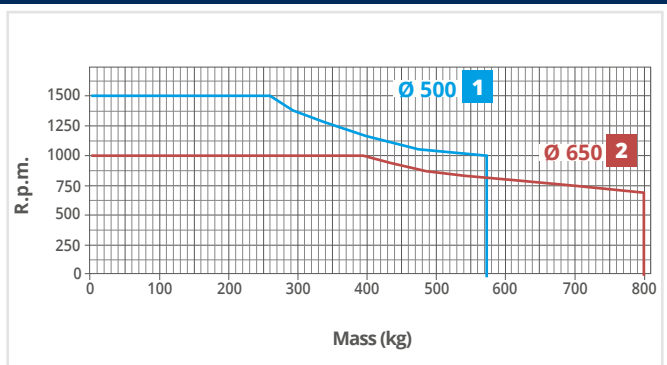

1 (*) Diagram is showing the rpm speed depending from:
 - total max weight on rotary plate (pallet + chuck or fixture + workpiece).
 - max overall dimension on rotary plate Ø 520 and 400 mm total length

2 (**) Diagram is showing the rpm speed depending from:
 - total max weight on rotary plate (pallet + chuck or fixture + workpiece).
 - max overall dimension on rotary plate Ø 650 and 450 mm total length

(*) (**) rpm max speed has to be reduced if used chuck type has lower rpm speed

Drawings and data are subject to change by SMW-Autoblok.

ROTARY PLATE Ø520: AVAILABLE PALLETS

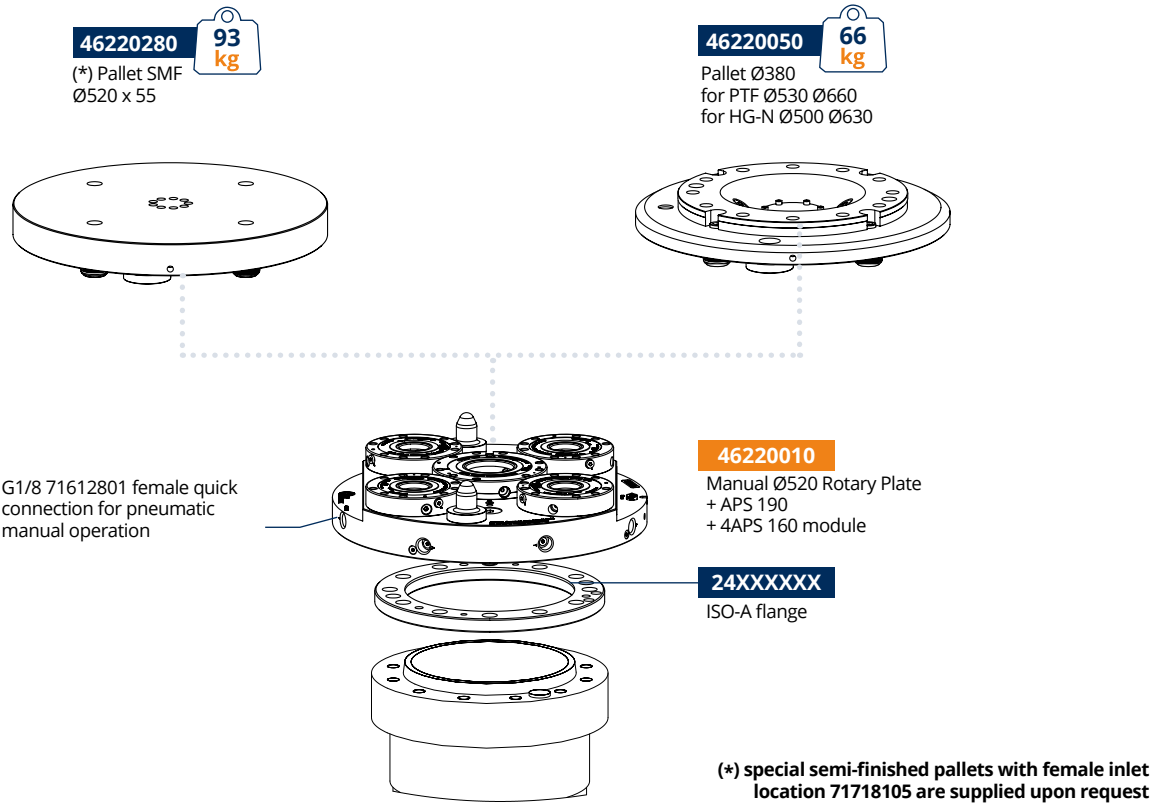

ROTARY PLATE Ø520: USABLE CHUCKS SCHEME

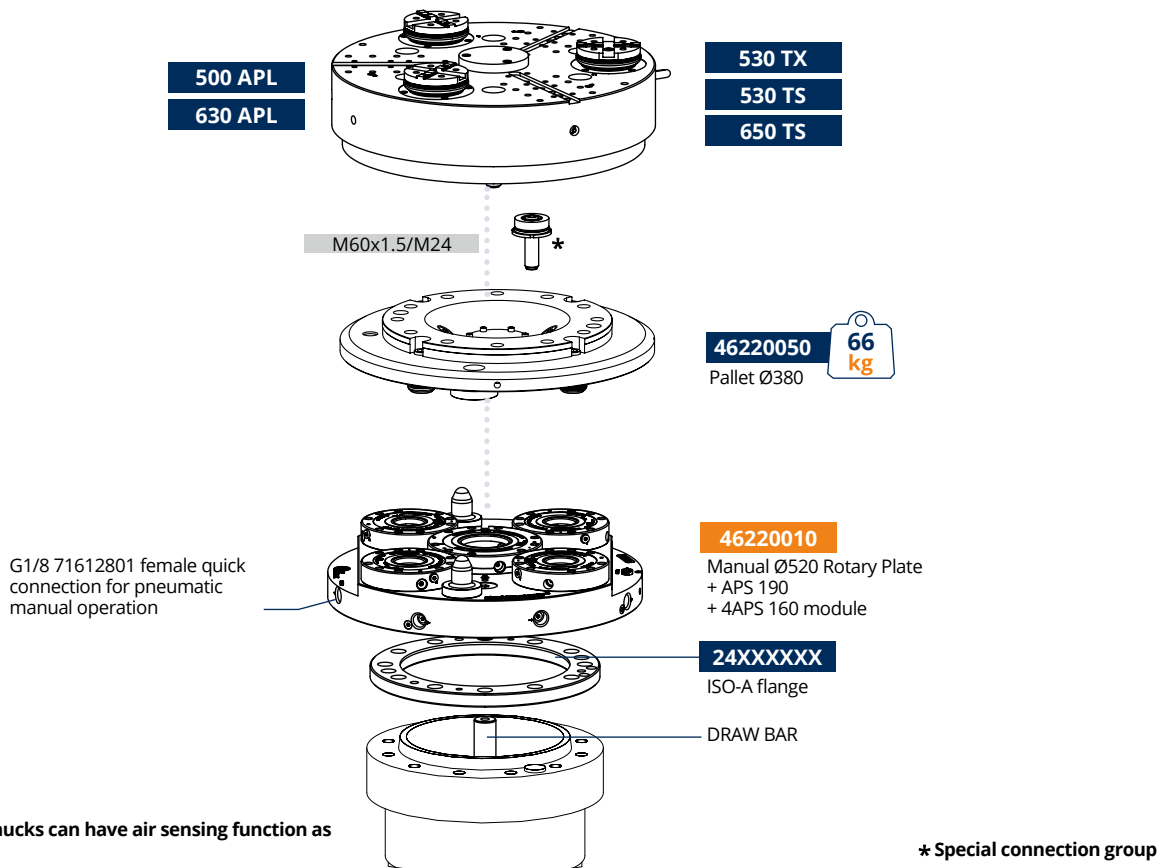

ROTARY PLATE Ø650

with APS 190 and 4 APS 160 manual operation

Manual tooling fast set-up for Ø 650 and Ø 800 pallets and chucks

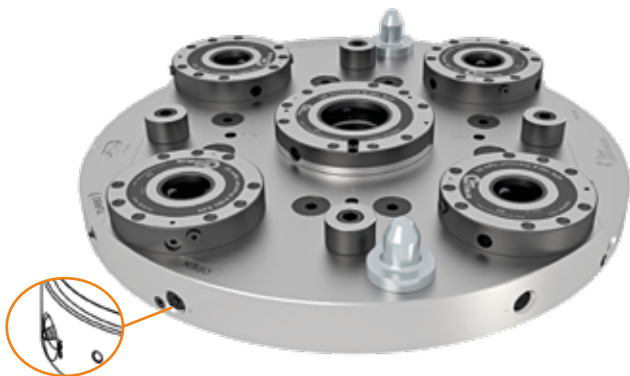

N. 2 PNEUMATIC CONNECTIONS FOR MANUAL OPENING AND TURBO COMMAND

Applications/Customer Benefits

- Pallet/Tooling fast set-up
- Chucks fast set-up Ø650 and Ø800 on turning spindles, manual connection (with screw) between chuck and cylinder
- Positioning accuracy < 0,005 mm

Technical features

- Case hardened main components to assure better accuracy and long operating life
- Pneumatic opening (OPEN)
- Closing by spring + Turbo function
- Opening/closing manually operated
- G6.3 balancing degree

ROTARY PLATE MODEL	ID.NO.	REPEATABILITY	CLAMPING FORCE BY TURBO FUNCTION AT 6 bar	MAX PRESSURE OPENING / CLOSING	WEIGHT Kg	CHUCK FEATURES			
						DRAW BAR MAX PULLING FORCE	DRAW BAR MAX PUSHING FORCE	Ø650 CHUCK MAX RPM (*)	Ø800 CHUCK MAX RPM (**)
Ø650 MANUAL	46220100	0,005 mm	165 kN	6 bar	170	100 kN	60 kN	1200	700

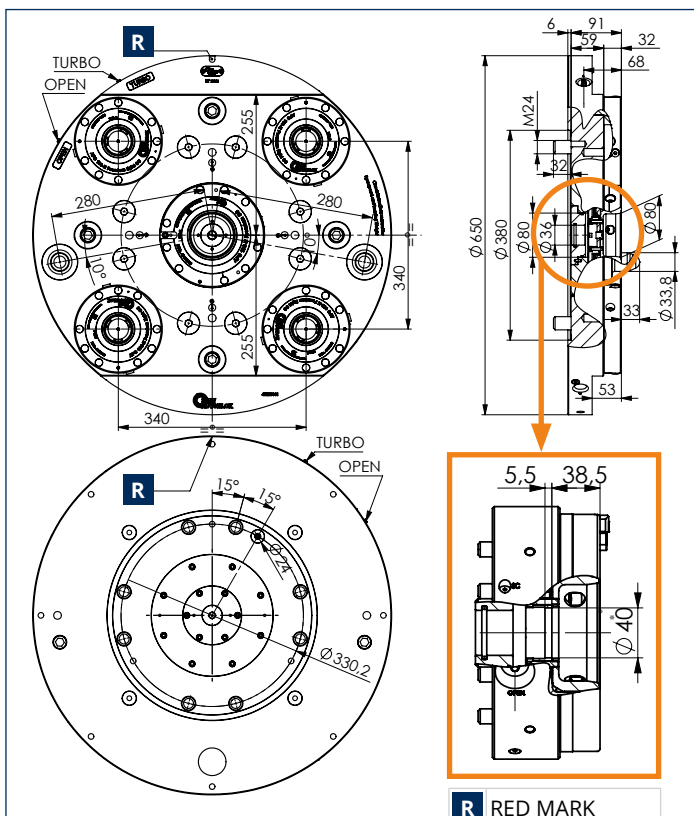

POWER CHUCK ASSEMBLY. In case of connection between draw bar and chuck, drill APS cover Ø40 hole assembled on machine tool.

Weight/Speed diagram

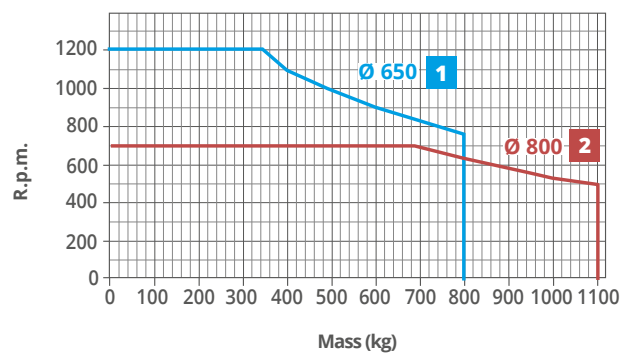

- (*) Diagram is showing the rpm speed depending from:
 - total max weight on rotary plate (pallet + chuck or fixture + workpiece).
 - max overall dimension on rotary plate Ø 650 and 450 mm total length
- (**) Diagram is showing the rpm speed depending from:
 - total max weight on rotary plate (pallet + chuck or fixture + workpiece).
 - max overall dimension on rotary plate Ø 800 and 450 mm total length

(*) (**) rpm max speed has to be reduced if used chuck type has lower rpm speed

ROTARY PLATE Ø650: AVAILABLE PALLETS

46220300 **179 kg**
 (*) Pallet SMF
 Ø800 x 45

46220290 **119 kg**
 (*) Pallet SMF
 Ø650 x 45

46220180 **99 kg**
 Pallet Ø520
 for PTF Ø800
 for HG-NB Ø800

46220060 **95 kg**
 Pallet Ø380
 for PTF Ø660
 for HG-N Ø630

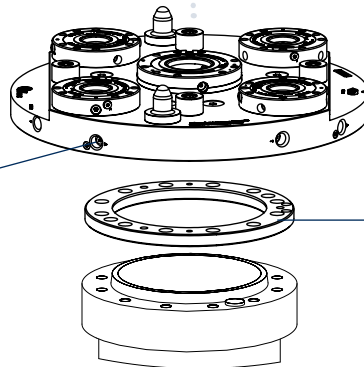
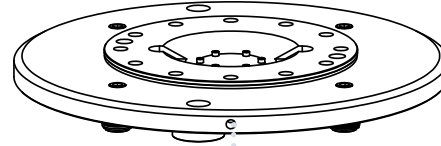
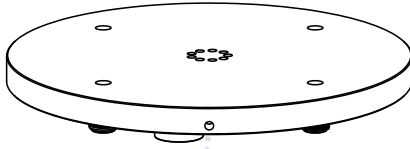

G1/8 71612801 female quick connection for pneumatic manual operation

46220100
 Manual Ø650 Rotary Plate
 + APS 190
 + 4 APS 160 module

24XXXXXX
 ISO-A flange

(*) special semi-finished pallets with female inlet location 71718105 are supplied upon request

ROTARY PLATE Ø650: USABLE CHUCKS SCHEME

800 APL

630 APL**

** By special pallet, 650 TS chuck can be assembled

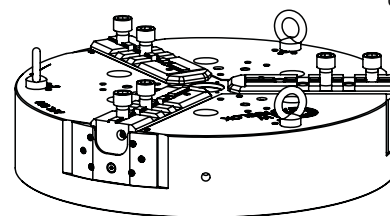
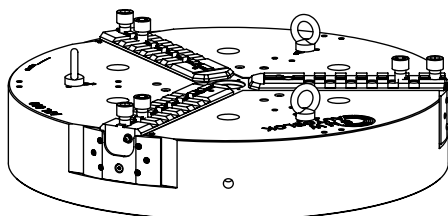

M60x1.5/M24 *

M60x1.5/M24

46220180 **99 kg**
 Pallet Ø520

46220060 **95 kg**
 Pallet Ø380

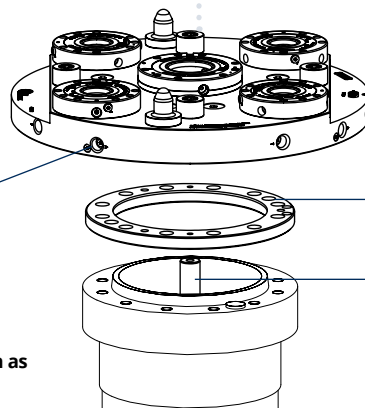

G1/8 71612801 female quick connection for pneumatic manual operation

46220100
 Manual Ø650 Rotary Plate
 + APS 190
 + 4 APS 160 module

24XXXXXX
 ISO-A flange

DRAW BAR

NOTE: all indicated chucks can have air sensing function as optional

* Special connection group

ROTARY PLATE $\varnothing 1000$

with APS 250 and 6 APS 160 manual operation

Manual tooling fast set-up for $\varnothing 1000$ and $\varnothing 1250$ pallets and chucks



N. 2 PNEUMATIC CONNECTIONS FOR MANUAL OPENING AND TURBO COMMAND

Applications/Customer Benefits

- Pallet/Tooling fast set-up
- Chucks fast set-up $\varnothing 1000$ and $\varnothing 1250$ on turning spindles, manual connection (with screw) between chuck and cylinder
- Positioning accuracy < 0,005 mm

Technical features

- Case hardened main components to assure better accuracy and long operating life
- Pneumatic opening
- Closing by spring + Turbo function
- Opening/closing manually operated
- G6.3 balancing degree

ROTARY PLATE MODEL	ID.NO.	REPEATABILITY	CLAMPING FORCE BY TURBO FUNCTION AT 6 bar	MAX PRESSURE OPENING / CLOSING	WEIGHT Kg	CHUCK FEATURES			
						DRAW BAR MAX PULLING FORCE	DRAW BAR MAX PUSHING FORCE	$\varnothing 1000$ CHUCK MAX RPM (*)	$\varnothing 1250$ CHUCK MAX RPM (**)
$\varnothing 1000$ MANUAL	46220030	0,005 mm	235 kN	6 bar	400	180 kN	110 kN	630	500

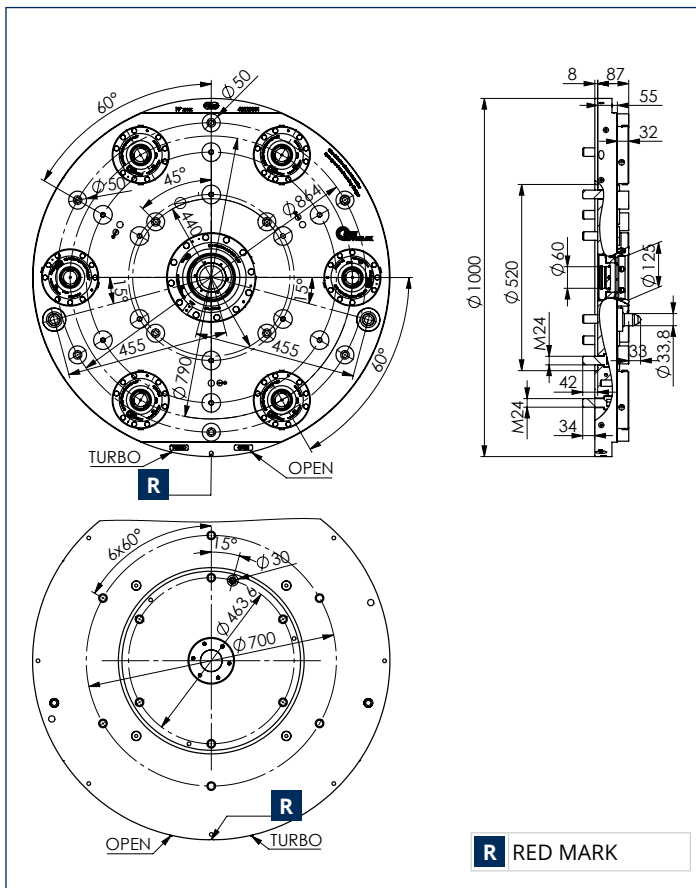

Weight/Speed diagram

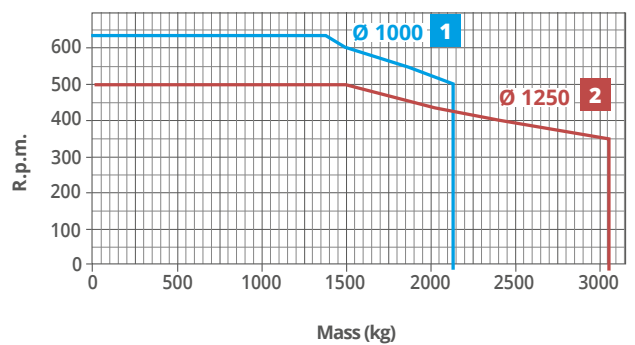

- 1** (*) Diagram is showing the rpm speed depending from:
- total max weight on rotary plate (pallet + chuck or fixture + workpiece).
 - max overall dimension on rotary plate $\varnothing 1000$ and 450 mm total length
- 2** (***) Diagram is showing the rpm speed depending from:
- total max weight on rotary plate (pallet + chuck or fixture + workpiece).
 - max overall dimension on rotary plate $\varnothing 1250$ and 450 mm total length

(*) (***) rpm max speed has to be reduced if used chuck type has lower rpm speed

ROTARY PLATE Ø1000: AVAILABLE PALLETS

46220310

278
kg

Pallet SMF
Ø1000 x 45

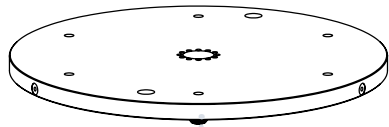

46220320

435
kg

Pallet SMF
Ø1250 x 45

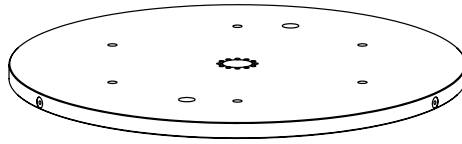

46220070

230
kg

Pallet Ø520
for PTF Ø1000 Ø1250
for HG Ø800

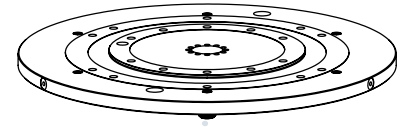

G1/8 71612801 female quick
connection for pneumatic
manual operation

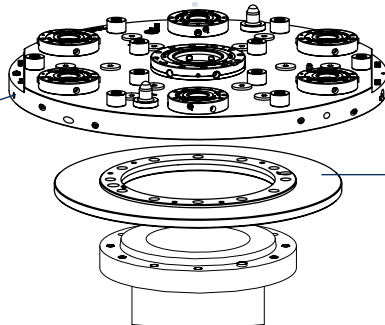

46220030

Manual Ø1000 Rotary Plate
+ APS 250
+ 6 APS 160 module

Special flange or direct
assembly on machine spindle

NOTE: for 1000 HG chuck,
special pallet to be required

ROTARY PLATE Ø1000: USABLE CHUCKS SCHEME

1000 IEP

1250 IEP

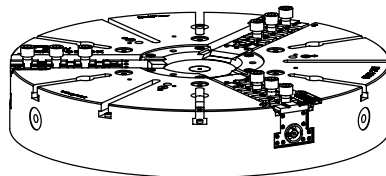

1000 IN 3-4-6 jaws

1250 IN 3-4-6 jaws

1000 IR 3-4-6 jaws

1250 IR 3-4-6 jaws



Special connection group

46220070

230
kg

Pallet Ø520

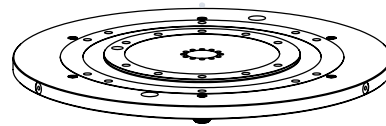

G1/8 71612801 female quick
connection for pneumatic
manual operation

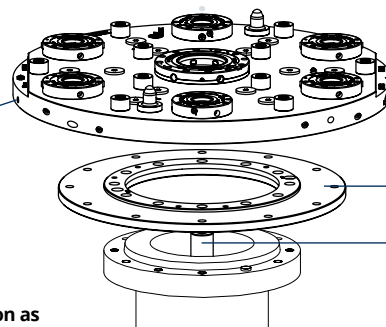

46220030

Manual Ø1000 Rotary Plate
+ APS 250
+ 6 APS 160 module

Special flange or direct
assembly on machine spindle

DRAW BAR

NOTE: all indicated chucks can have air sensing function as
optional

ROTARY PLATE $\varnothing 1400$

with APS 250 and 8 APS 160 manual operation

Manual tooling fast set-up for $\varnothing 1400-1600$ and $\varnothing 1800$ pallets and chucks

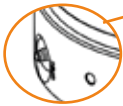
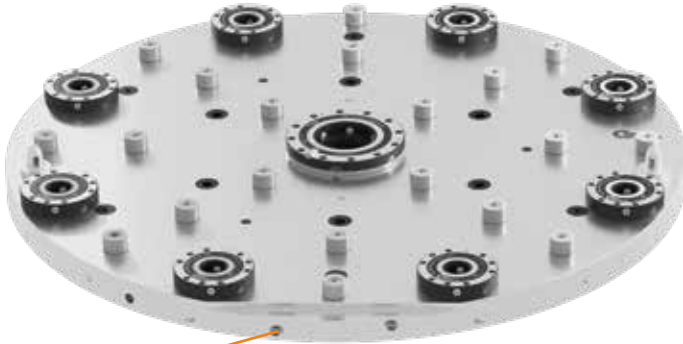

N. 2 PNEUMATIC CONNECTIONS FOR MANUAL OPENING AND TURBO COMMAND

Applications/Customer Benefits

- Pallet/Tooling fast set-up
- Chucks fast set-up $\varnothing 1400$, $\varnothing 1600$ and $\varnothing 1800$ on turning spindles, manual connection (with screw) between chuck and cylinder
- Positioning accuracy < 0,005 mm

Technical features

- Case hardened main components to assure better accuracy and long operating life
- Pneumatic opening (OPEN)
- Closing by spring + Turbo function
- Opening/closing manually operated
- G6.3 balancing degree

ROTARY PLATE MODEL	ID.NO.	REPEATABILITY	CLAMPING FORCE BY TURBO FUNCTION AT 6 bar	MAX PRESSURE OPENING / CLOSING	WEIGHT Kg	CHUCK FEATURES				
						DRAW BAR MAX PULLING FORCE	DRAW BAR MAX PUSHING FORCE	$\varnothing 1400$ CHUCK MAX RPM (*)	$\varnothing 1600$ CHUCK MAX RPM (**)	$\varnothing 1800$ CHUCK MAX RPM (***)
$\varnothing 1400$ MANUAL	46220040	0,005 mm	295 kN	6 bar	790	200 kN	120 kN	450	400	350

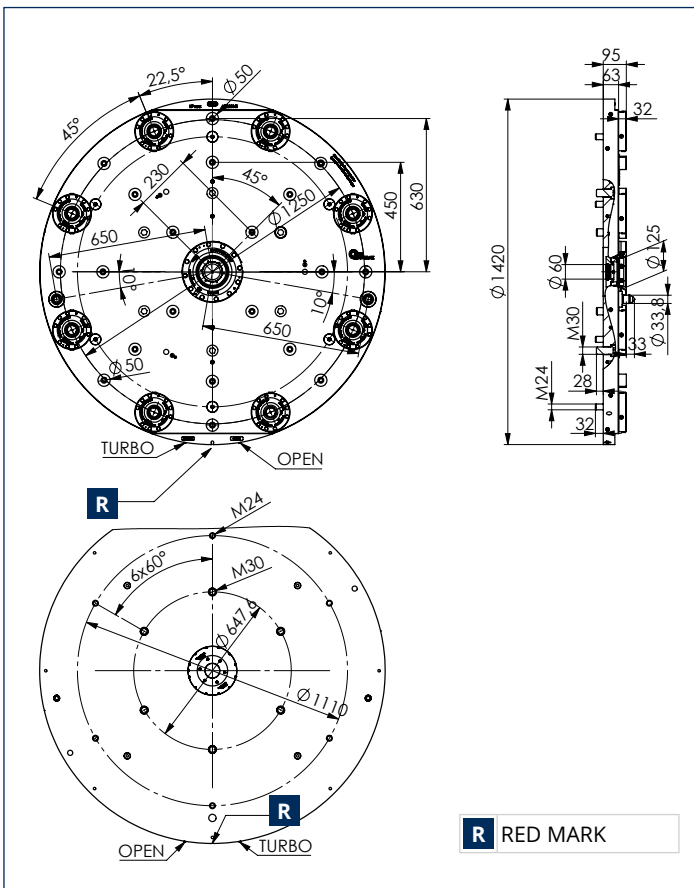

Weight/Speed diagram

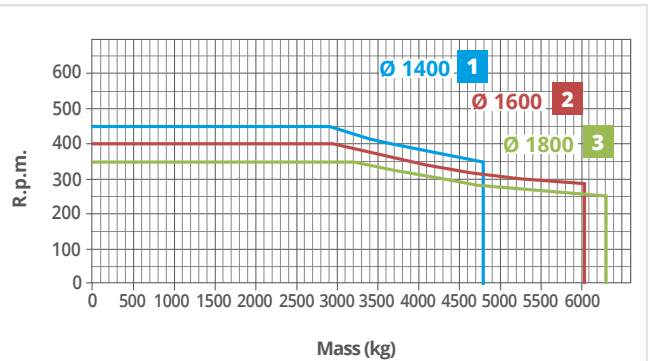

- (*) Diagram is showing the rpm speed depending from:
 - total max weight on rotary plate (pallet + chuck or fixture + workpiece).
 - max overall dimension on rotary plate $\varnothing 1400$ and 550 mm total length
- (**) Diagram is showing the rpm speed depending from:
 - total max weight on rotary plate (pallet + chuck or fixture + workpiece).
 - max overall dimension on rotary plate $\varnothing 1600$ and 550 mm total length
- (***) Diagram is showing the rpm speed depending from:
 - total max weight on rotary plate (pallet + chuck or fixture + workpiece).
 - max overall dimension on rotary plate $\varnothing 1800$ and 550 mm total length

(*) (**) (***) rpm max speed has to be reduced if used chuck type has lower rpm speed

Drawings and data are subject to change by SMW-Autoblok.

ROTARY PLATE Ø1400: AVAILABLE PALLETS

46220330

560
kg

Pallet SMF
Ø1420 x 45

46220340

710
kg

Pallet SMF
Ø1600 x 45

46220080

465
kg

Pallet Ø720
for PTF Ø1400 Ø1600

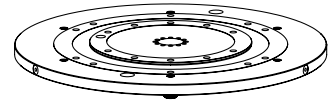
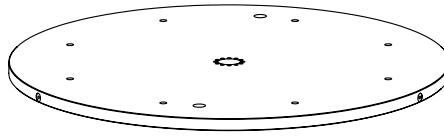
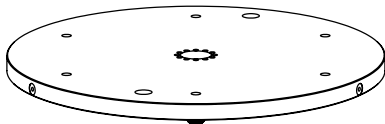

G1/8 71612801 female quick connection for pneumatic manual operation

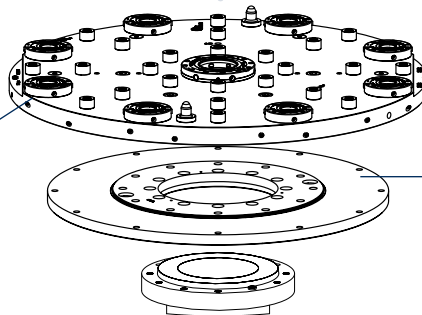

46220040

Manual Ø1400 Rotary Plate
+ APS 250
+ 8 APS 160 module

Special flange or direct assembly on machine spindle

ROTARY PLATE Ø1400: USABLE CHUCKS SCHEME

1400 IEP

1600 IEP

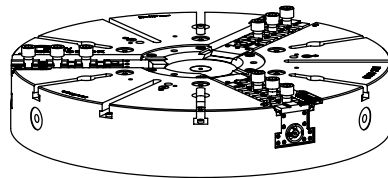

1400 IR

3-4-6 jaws

1600 IR

3-4-6 jaws

1800 IR

3-6 jaws

Special connection group

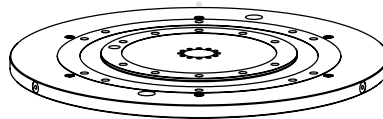

46220080

Pallet Ø720

465
kg

G1/8 71612801 female quick connection for pneumatic manual operation

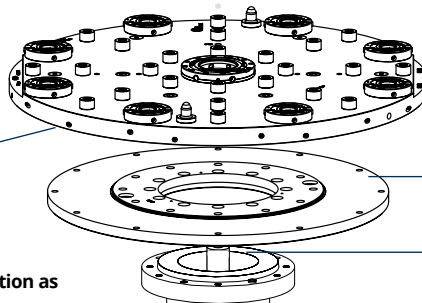

46220040

Manual Ø1400 Rotary Plate
+ APS 250
+ 8 APS 160 module

Special flange or direct assembly on machine spindle

DRAW BAR

NOTE: all indicated chucks can have air sensing function as optional

Recommended cylinders for ROTARY PLATE

Manual pallet fast set-up with chucks.
Connection between the chuck and the draw bar is made by screw.

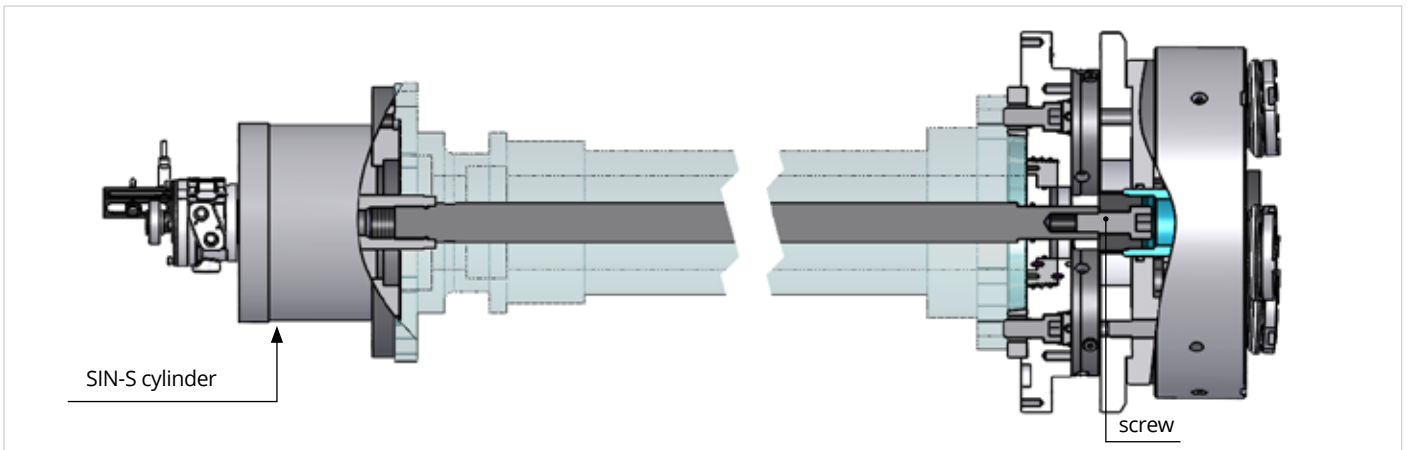

RECOMMENDED CYLINDERS								
ROTARY PLATE TYPE	TS / TX	➔ SIN	AP	➔ SIN	IR	/ IN	/ IEP	➔ SIN
Ø202	170	85 SIN-S	170	100 SIN-S	-	-	-	-
	210	100 SIN-S	210	125 SIN-S	-	-	-	-
Ø260	210	100 SIN-S	210	125 SIN-S	-	-	-	-
	210-315	125 SIN-S	250-315	150 SIN-S	-	-	-	-
Ø330	250-315	125 SIN-S	250-315	150 SIN-S	-	-	-	-
Ø420	400	150 SIN-S	400	175 SIN-S	-	-	-	-
Ø520	530-650	150 SIN-S	500-630	200 SIN-S	-	-	-	-
Ø650	650	175 SIN-S	630-800	200 SIN-S	-	-	-	-
Ø1000	-	-	-	-	1000-1250	1000-1250	1000-1250	200 SIN-S (*)
Ø1400	-	-	-	-	1400-1600-1800	-	1400-1600	200 SIN-S (*)

(*) 1000/1250/1400/1600/1800 IR/IN chucks have 50 mm reduced stroke of the wedge if used by the SIN-S 200 cylinder.

Manual tooling fast pallets set-up

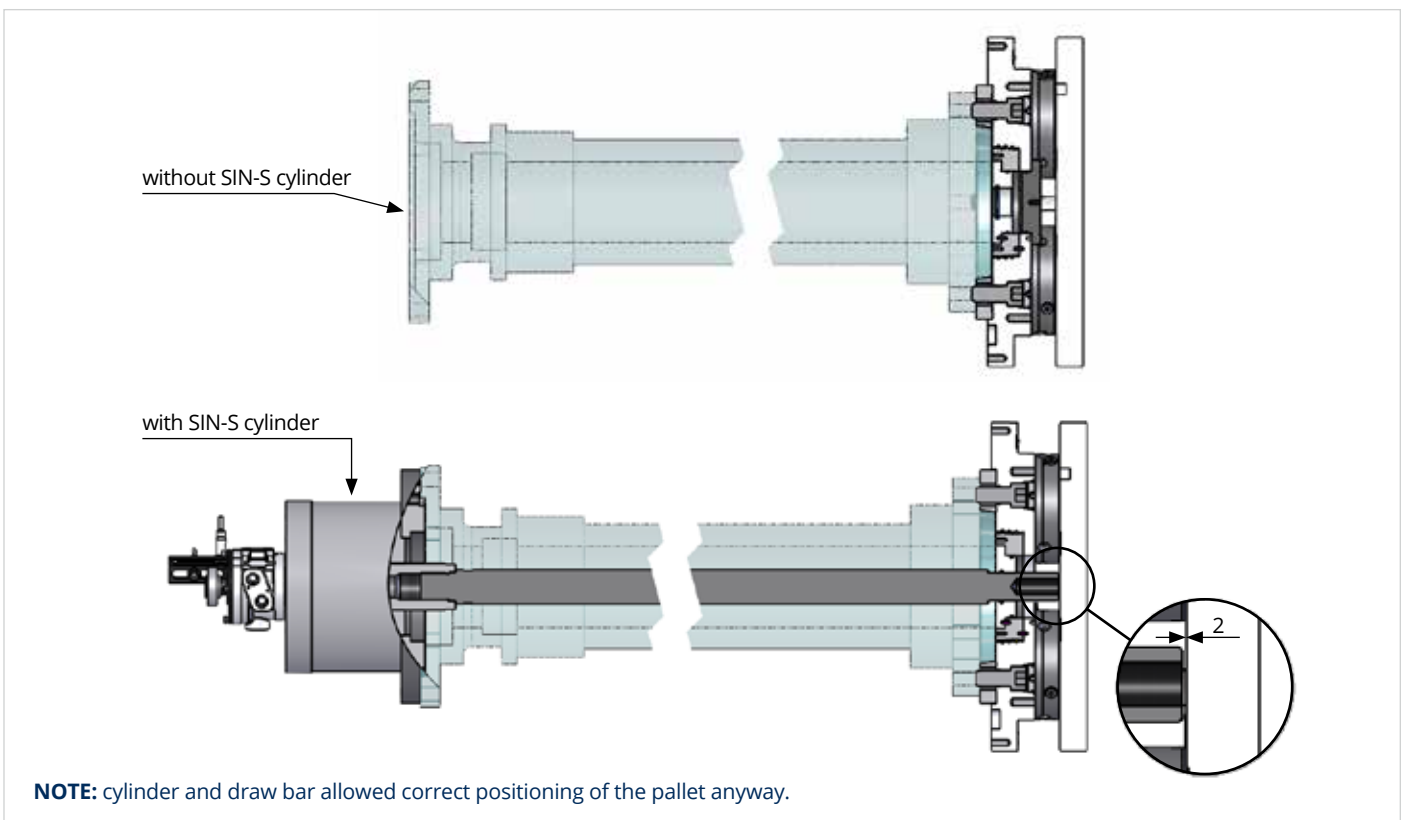

NOTE: cylinder and draw bar allowed correct positioning of the pallet anyway.

AUTOMATIC OPERATION

APS MODULES

3
b



Drawings and data are subject to change by SMW-AUTOBLOK.

ROTARY PLATE Ø260

with APS 250 automatic operation

Automatic or manual tooling fast set-up for Ø 210-250-315 turning workholding

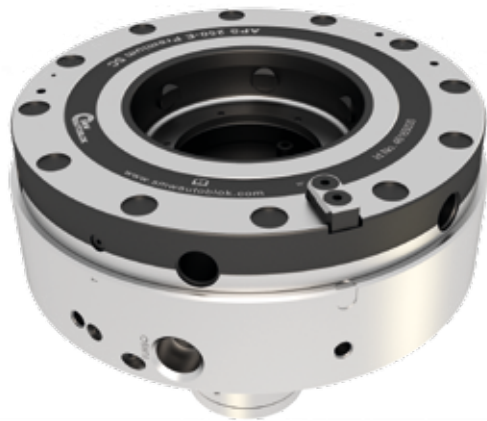

Applications/Customer Benefits

- Pallet/Tooling fast set-up on turning spindles
- Tooling presence Air sensing function
- SC stroke control function
- Positioning accuracy < 0,005 mm

Technical features

- Case hardened main components to assure better accuracy and long operating life
- Pneumatic opening
- Closing by spring + Turbo function
- Opening/closing automatically operated
- G6.3 balancing degree

ROTARY PLATE MODEL	ID.NO.	REPEATABILITY	CLAMPING FORCE BY TURBO FUNCTION AT 6 bar	MAX PRESSURE OPENING /CLOSING	AIR SENSING/SC STROKE CONTROL PRESSURE	Ø210 PALLET MAX RPM (*)	Ø250 PALLET MAX RPM (**)	Ø315 PALLET MAX RPM (***)	WEIGHT Kg
Ø260 AUTOMATIC	46220500	0,005 mm	55 kN	6 bar	0,5 bar	3500	3000	2000	30

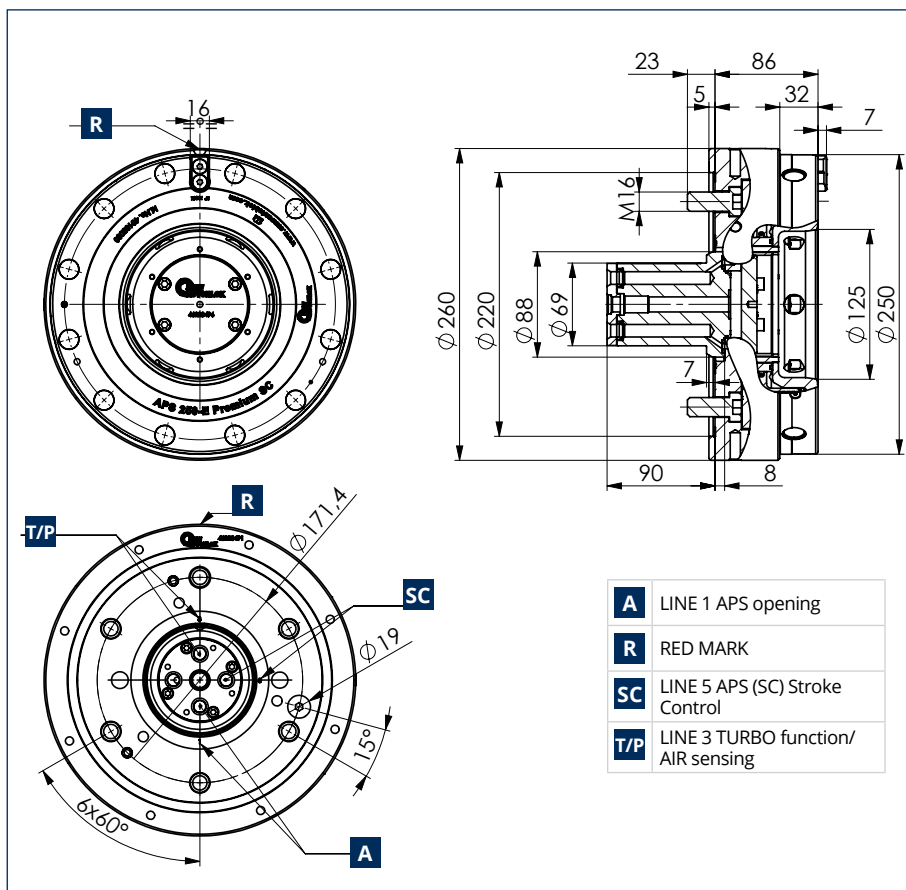

Weight/Speed diagram

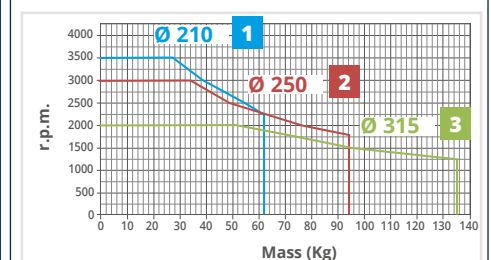

1 (*) Diagram is showing the rpm speed depending from:
 - total max weight on rotary plate (fixture + workpiece),
 - max overall dimension on rotary plate (fixture + workpiece)
 Ø 210 and 220 mm total length

2 (**) Diagram is showing the rpm speed depending from:
 - total max weight on rotary plate (fixture + workpiece),
 - max overall dimension on rotary plate (fixture + workpiece)
 Ø 250 and 250 mm total length

3 (***) Diagram is showing the rpm speed depending from:
 - total max weight on rotary plate (fixture + workpiece),
 - max overall dimension on rotary plate (fixture + workpiece)
 Ø 315 and 250 mm total length

Drawings and data are subject to change by SMW-Autoblok.

ROTARY PLATE Ø330

with 3 APS 140 automatic operation

Automatic or manual tooling fast set-up for Ø 330 turning workholding



Applications/Customer Benefits

- Pallet/Tooling fast set-up on turning spindles
- Tooling presence Air sensing function
- SC stroke control function
- Positioning accuracy < 0,005 mm

Technical features

- Case hardened main components to assure better accuracy and long operating life
- Pneumatic opening
- Closing by spring + Turbo function
- Opening/closing automatically operated
- G6.3 balancing degree

ROTARY PLATE MODEL	ID.NO.	REPEATABILITY	CLAMPING FORCE BY TURBO FUNCTION AT 6 bar	MAX PRESSURE OPENING /CLOSING	AIR SENSING/SC STROKE CONTROL PRESSURE	Ø330 PALLET MAX RPM (*)	WEIGHT Kg
Ø330 AUTOMATIC.	46220360	0,005 mm	78 kN	6 bar	0,5 bar	2000	43

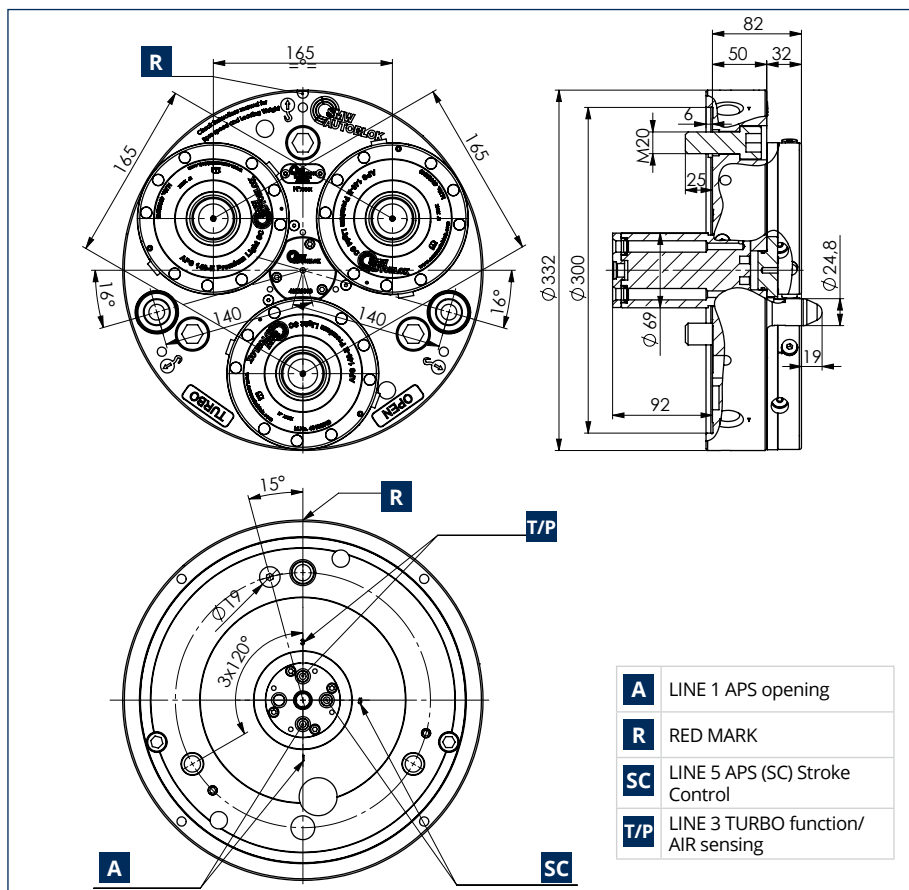

Weight/Speed diagram

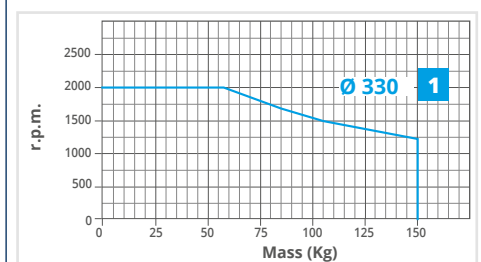

1 (*) Diagram is showing the rpm speed depending from:

- total max weight on rotary plate (fixture + workpiece).
- max overall dimension on rotary plate (fixture + workpiece) Ø 330 and 250 mm total length

ROTARY PLATE Ø650

with APS 190 and 4 APS 160 automatic operation

Automatic or manual tooling fast set-up for Ø 650 and Ø 800 turning workholding



Applications/Customer Benefits

- Pallet/Tooling fast set-up on turning spindles
- Tooling presence Air sensing function
- SC stroke control function
- Positioning accuracy < 0,005 mm

Technical features

- Case hardened main components to assure better accuracy and long operating life
- Pneumatic opening
- Closing by spring + Turbo function
- Opening/closing automatically operated
- G6.3 balancing degree

ROTARY PLATE MODEL	ID.NO.	REPEATABILITY	CLAMPING FORCE BY TURBO FUNCTION AT 6 bar	MAX PRESSURE OPENING /CLOSING	AIR SENSING/SC STROKE CONTROL PRESSURE	Ø650 PALLET MAX RPM (*)	Ø800 PALLET MAX RPM (**)	WEIGHT Kg
Ø650 AUTOMATIC	46220140	0,005 mm	165 kN	6 bar	0,5 bar	1200	700	173

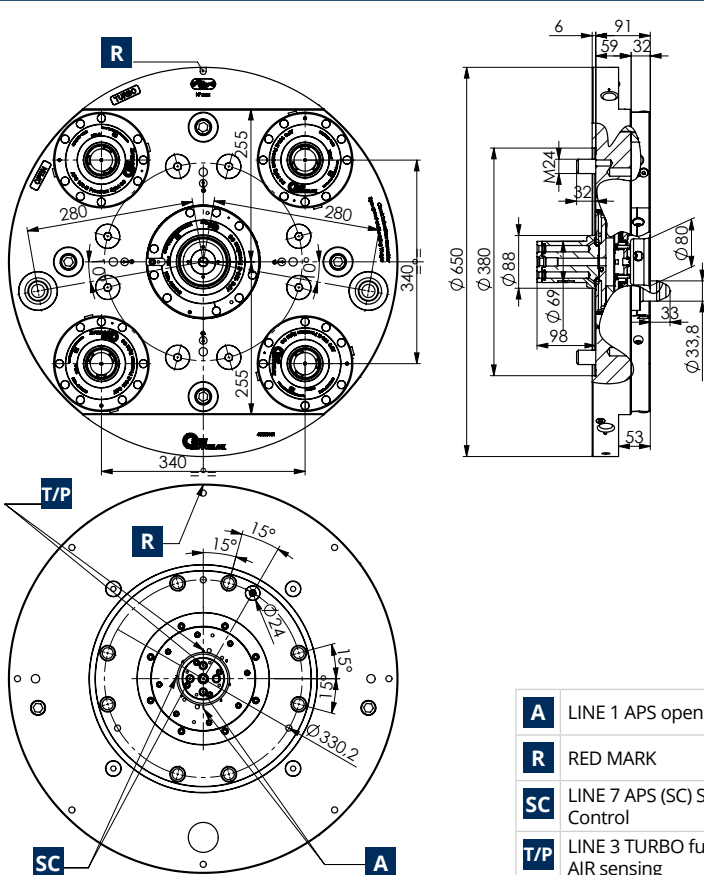

A	LINE 1 APS opening
R	RED MARK
SC	LINE 7 APS (SC) Stroke Control
T/P	LINE 3 TURBO function/ AIR sensing

Weight/Speed diagram

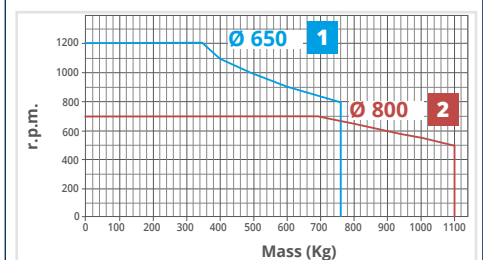

1 (*) Diagram is showing the rpm speed depending from:

- total max weight on rotary plate (fixture + workpiece).
- max overall dimension on rotary plate (fixture + workpiece) Ø 630 and 450 mm total length

2 (***) Diagram is showing the rpm speed depending from:

- total max weight on rotary plate (fixture + workpiece).
- max overall dimension on rotary plate (fixture + workpiece) Ø 630 and 450 mm total length

ROTARY PLATE ASSEMBLY LINE

Automatic operation APS modules

Manual or automatic pallet tooling fast set-up

Pallet  FOR EACH SIZE, CHECK RELATED PALLETS

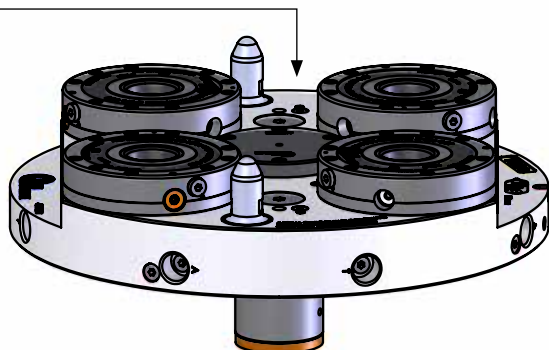

Mod. Id.No. AUTOMATIC ROTARY PLATE

Ø202	46220460
Ø260	46220500
Ø330	46220360
Ø420	46220400
Ø520	46220090
Ø650	46220140

ISO-A flange  [VIEW ACCESSORIES](#)

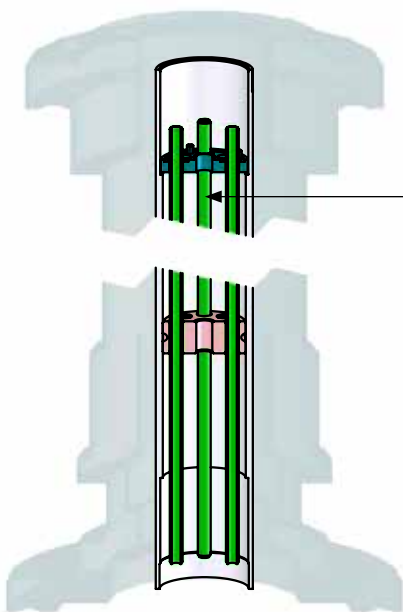

Pipe bundle

(to customize for each machine tool specifically)

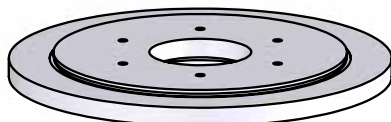

Manifold flange

(to customize for each machine tool specifically)

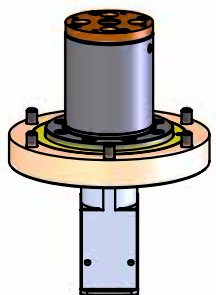

60580011  [VIEW ACCESSORIES](#)

3-pneumatic feedings manifold

PIPE BUNDLE for Automatic operation of APS modules

PIPE BUNDLE assembly from ROTARY PLATE side

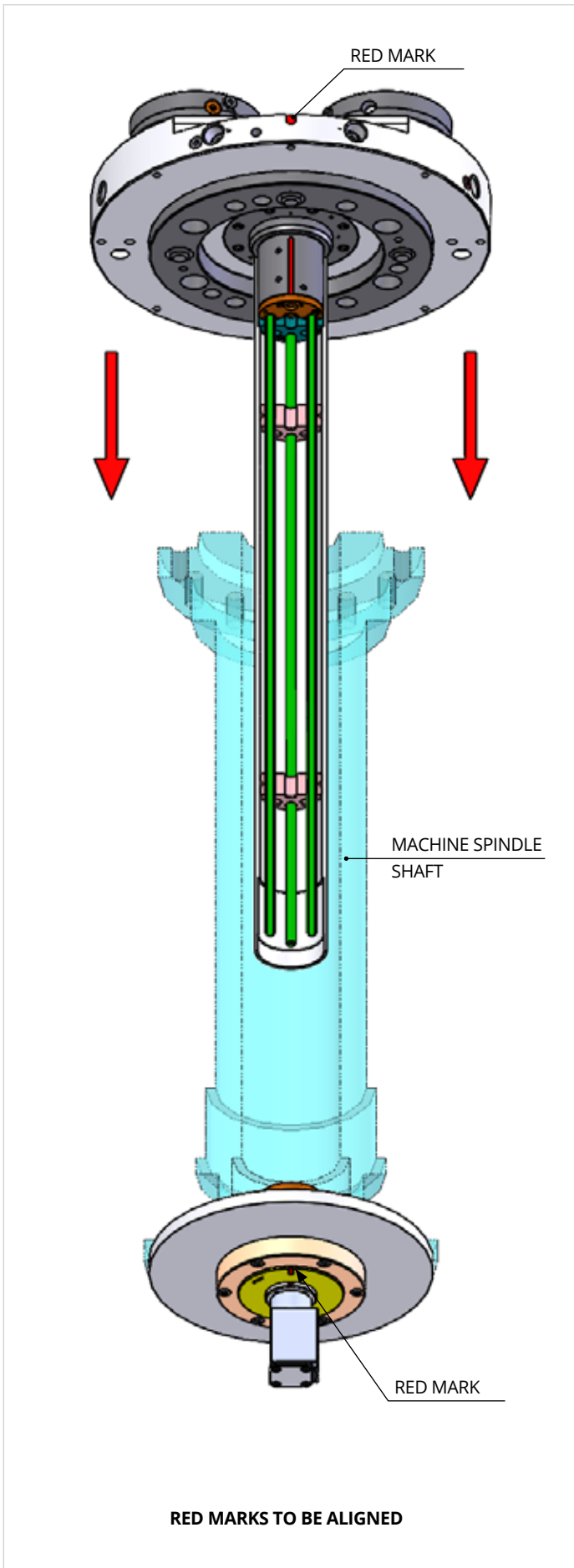

PIPE BUNDLE assembly from MANIFOLD side

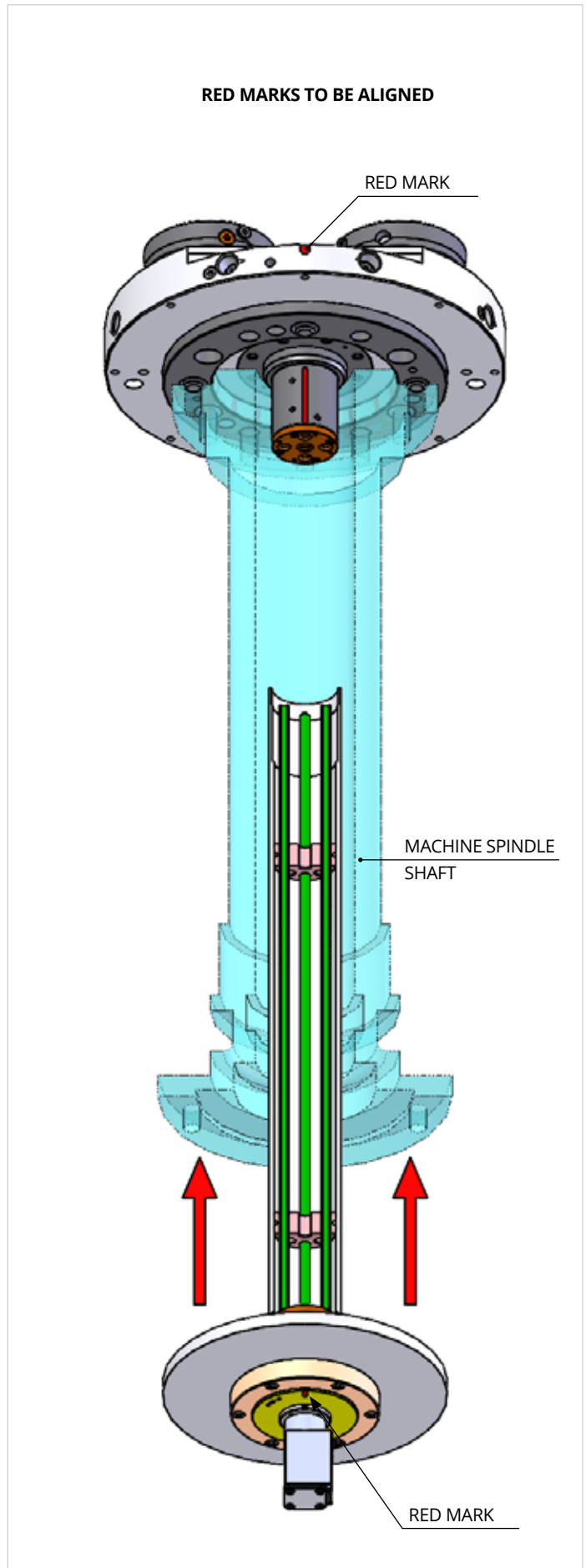

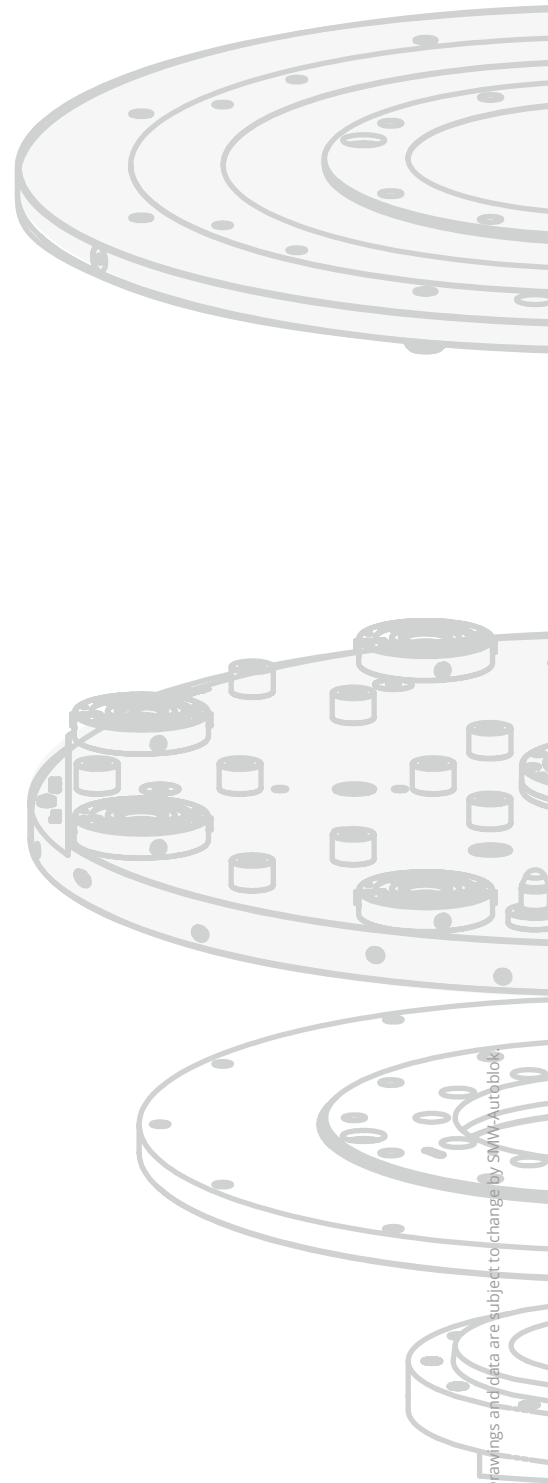

Drawings and data are subject to change by SMW-Autoblok

AUTOMATIC OPERATION

+3 APS MODULES PNEUMATIC FEEDINGS FOR FIXTURE CONTROL ON PALLET

3
c

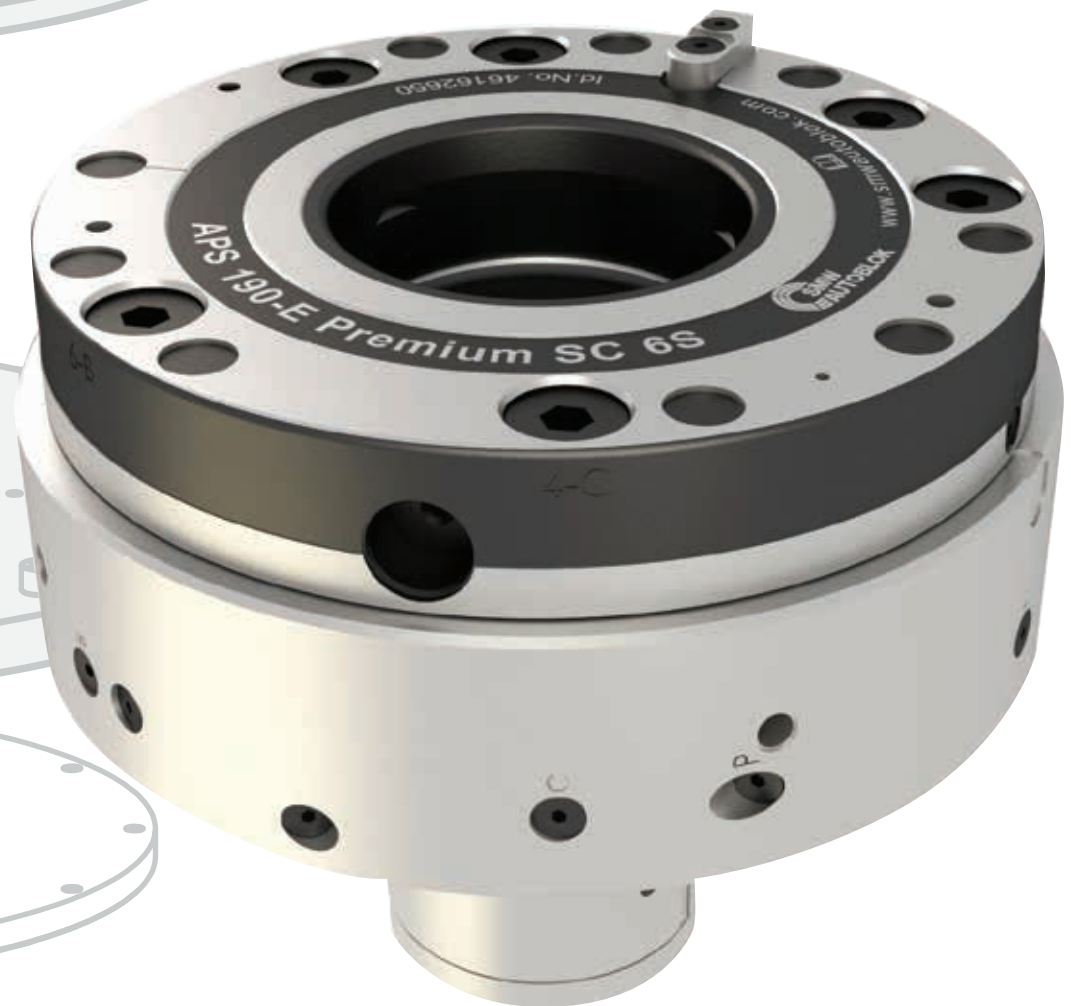

Drawings and data are subject to change by SMW-Autoblok

ROTARY PLATE Ø202

with APS 190 automatic operation

+3 PNEUMATIC FEEDINGS ON PALLET

Automatic or manual tooling fast set-up for Ø 170 and Ø 210 on turning workholding



Applications/Customer Benefits

- Pallet/Tooling fast set-up on turning spindles
- Tooling presence Air sensing function
- SC stroke control function
- Positioning accuracy < 0,005 mm
- **3 pneumatic feedings available on pallet**

Technical features

- Case hardened main components to assure better accuracy and long operating life
- Pneumatic opening
- Closing by spring + Turbo function
- Opening/closing automatically operated
- G6.3 balancing degree

ROTARY PLATE MODEL	ID.NO.	REPEATABILITY	CLAMPING FORCE BY TURBO AT 6 bar	MAX PRESSURE OPENING / CLOSING	AIR SENSING/ SC STROKE CONTROL PRESSURE	Ø170 PALLET MAX RPM (*)	Ø210 PALLET MAX RPM (**)	WEIGHT Kg
Ø202 AUTOMATIC +3AIR	46220480	0,005 mm	45 kN	6 bar	0,5 bar	1500	1500	18

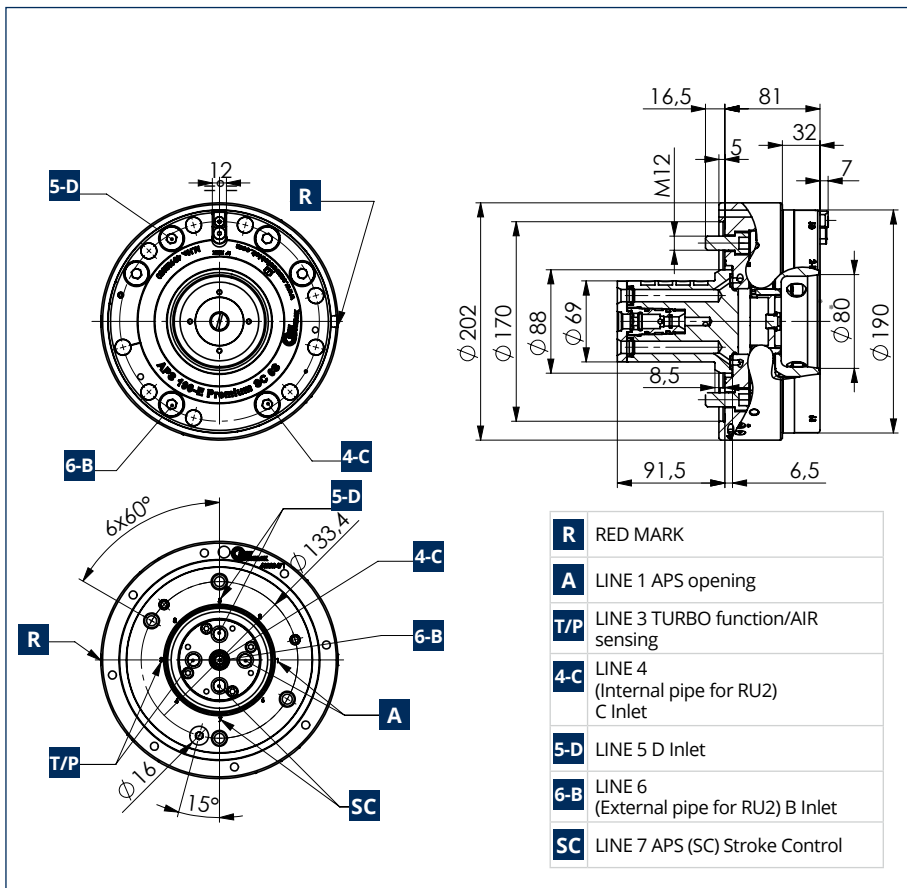

Weight/Speed diagram

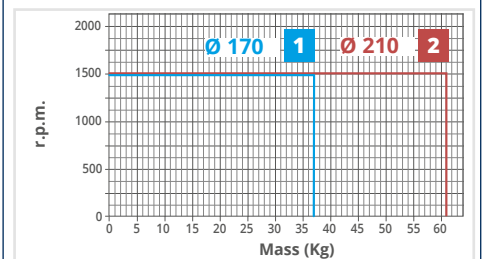

1 (*) Diagram is showing the rpm speed depending from:

- total max weight on rotary plate (fixture + workpiece).
- max overall dimension on rotary plate (fixture + workpiece) Ø 175 and 190 mm total length

2 (**) Diagram is showing the rpm speed depending from:

- total max weight on rotary plate (fixture + workpiece).
- max overall dimension on rotary plate (fixture + workpiece) Ø 210 and 220 mm total length

ROTARY PLATE Ø260

with APS 250 automatic operation

+3 PNEUMATIC FEEDINGS ON PALLET

Automatic or manual tooling fast set-up for Ø 210-250-315 on turning workholding



Applications/Customer Benefits

- Pallet/Tooling fast set-up on turning spindles
- Tooling presence Air sensing function
- SC stroke control function
- Positioning accuracy < 0,005 mm
- **3 pneumatic feedings available on pallet**

Technical features

- Case hardened main components to assure better accuracy and long operating life
- Pneumatic opening
- Closing by spring + Turbo function
- Opening/closing automatically operated
- G6.3 balancing degree

ROTARY PLATE MODEL	ID.NO.	REPEATABILITY	CLAMPING FORCE BY TURBO AT 6 bar	MAX PRESSURE OPENING / CLOSING	AIR SENSING/ SC STROKE CONTROL PRESSURE	Ø210 PALLET MAX RPM (*)	Ø250 PALLET MAX RPM (**)	Ø315 PALLET MAX RPM (***)	WEIGHT Kg
Ø260 AUTOMATIC +3AIR	46220520	0,005 mm	55 kN	6 bar	0,5 bar	1500	1500	1500	30

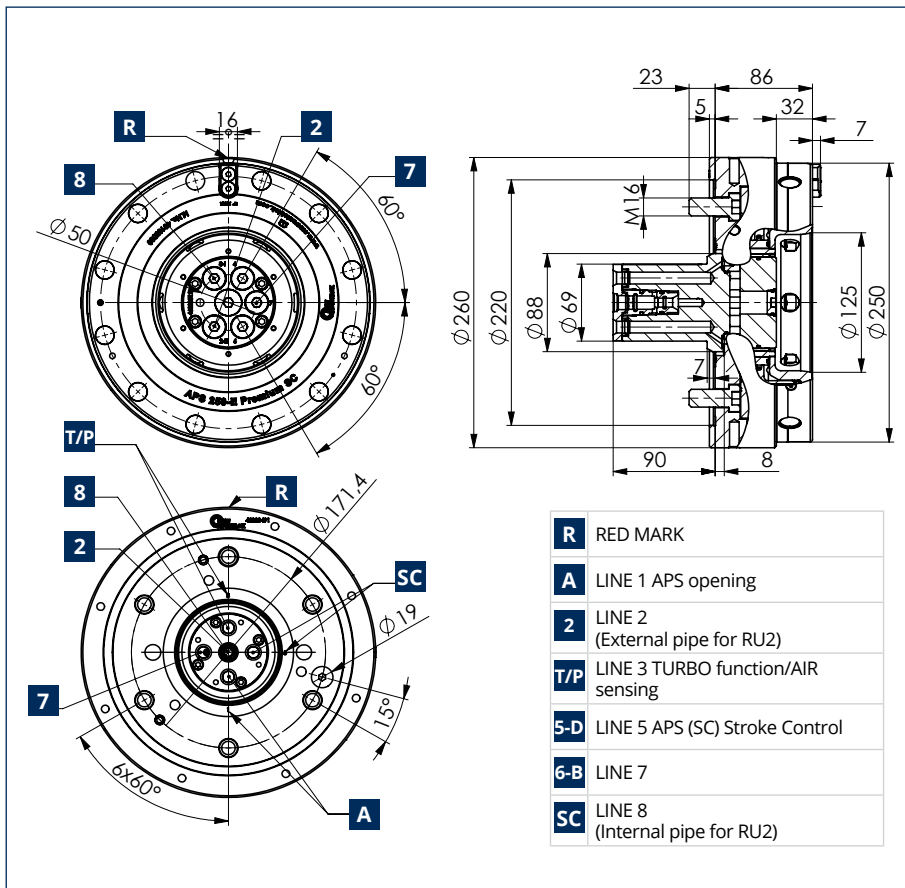

Weight/Speed diagram

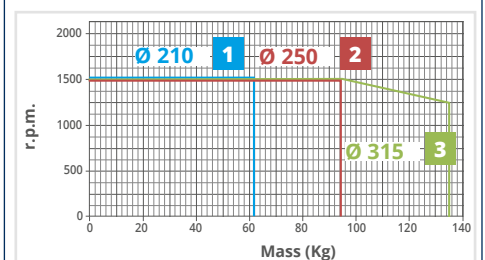

- 1** (*) Diagram is showing the rpm speed depending from:
- total max weight on rotary plate (fixture + workpiece).
 - max overall dimension on rotary plate (fixture + workpiece) Ø 210 and 220 mm total length
- 2** (**) Diagram is showing the rpm speed depending from:
- total max weight on rotary plate (fixture + workpiece).
 - max overall dimension on rotary plate (fixture + workpiece) Ø 250 and 250 mm total length
- 3** (***) Diagram is showing the rpm speed depending from:
- total max weight on rotary plate (fixture + workpiece).
 - max overall dimension on rotary plate (fixture + workpiece) Ø 315 and 250 mm total length

ROTARY PLATE Ø420

with 4 APS 140 automatic operation

+3 PNEUMATIC FEEDINGS ON PALLET

Automatic or manual tooling fast set-up for Ø 400 on turning workholding



Applications/Customer Benefits

- Pallet/Tooling fast set-up on turning spindles
- Tooling presence Air sensing function
- SC stroke control function
- Positioning accuracy < 0,005 mm
- **3 pneumatic feedings available on pallet**

Technical features

- Case hardened main components to assure better accuracy and long operating life
- Pneumatic opening
- Closing by spring + Turbo function
- Opening/closing automatically operated
- G6.3 balancing degree

ROTARY PLATE MODEL	ID.NO.	REPEATABILITY	CLAMPING FORCE BY TURBO AT 6 bar	MAX PRESSURE OPENING / CLOSING	AIR SENSING/ SC STROKE CONTROL PRESSURE	Ø400 PALLET MAX RPM (*)	WEIGHT Kg
Ø420 AUTOMATIC +3AIR	46220420	0,005 mm	104 kN	6 bar	0,5 bar	1500	67

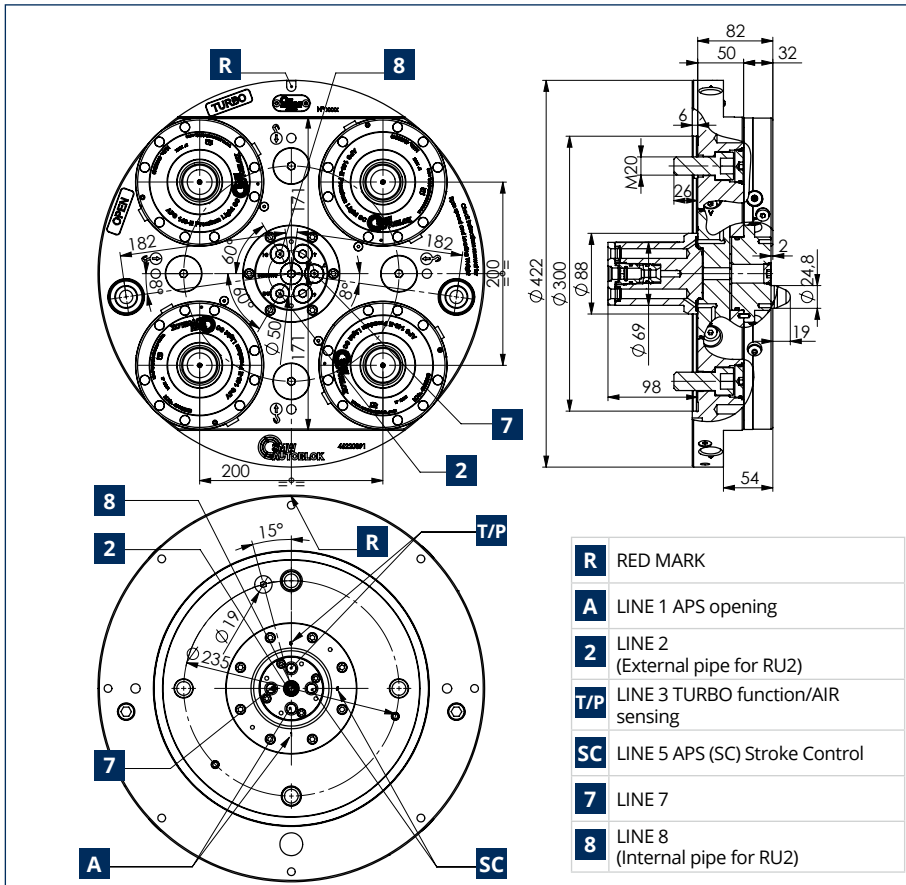

Weight/Speed diagram

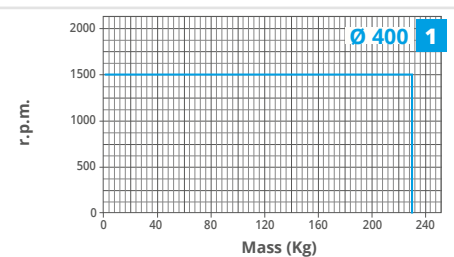

1 (*) Diagram is showing the rpm speed depending from:

- total max weight on rotary plate (fixture + workpiece).
- max overall dimension on rotary plate (fixture + workpiece) Ø 420 and 300 mm total length

ROTARY PLATE Ø520

with APS 190 and 4 APS 160 automatic operation

+3 PNEUMATIC FEEDINGS ON PALLET

Automatic or manual tooling fast set-up for Ø 500 on turning workholding



Applications/Customer Benefits

- Pallet/Tooling fast set-up on turning spindles
- Tooling presence Air sensing function
- SC stroke control function
- Positioning accuracy < 0,005 mm
- **3 pneumatic feedings available on pallet**

Technical features

- Case hardened main components to assure better accuracy and long operating life
- Pneumatic opening
- Closing by spring + Turbo function
- Opening/closing automatically operated
- G6.3 balancing degree

ROTARY PLATE MODEL	ID.NO.	REPEATABILITY	CLAMPING FORCE BY TURBO AT 6 bar	MAX PRESSURE OPENING / CLOSING	AIR SENSING/ SC STROKE CONTROL PRESSURE	Ø500 PALLET MAX RPM (*)	WEIGHT Kg
Ø520 AUTOMATIC +3AIR	46220430	0,005 mm	165 kN	6 bar	0,5 bar	1500	115

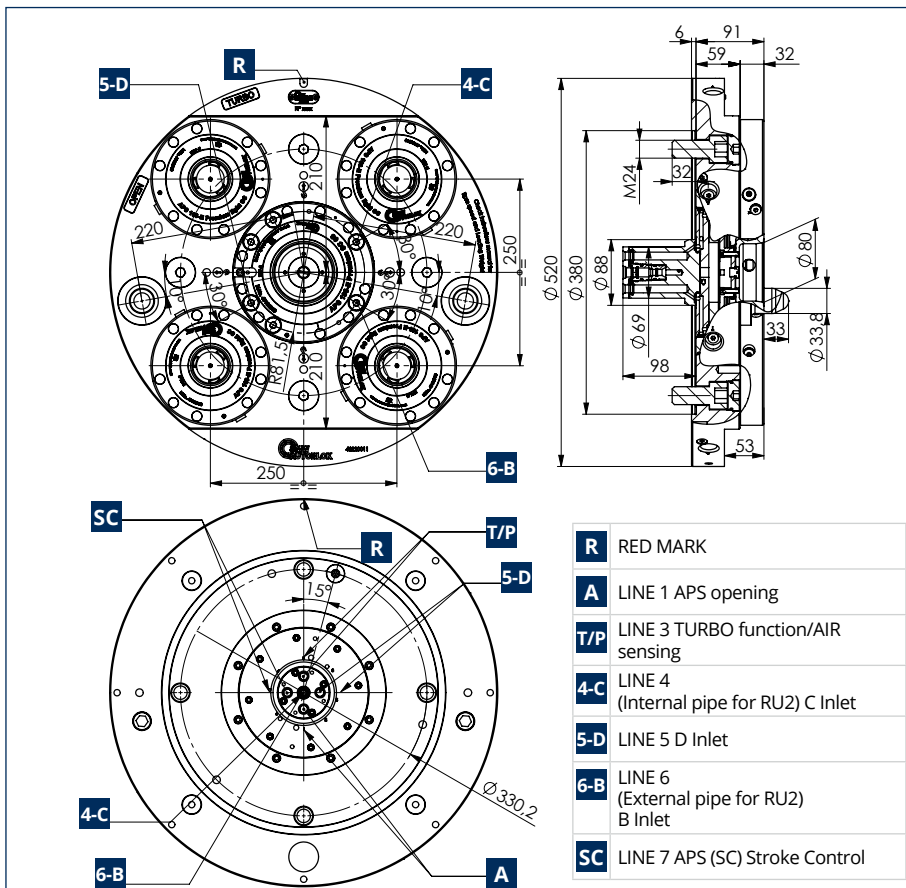

Weight/Speed diagram

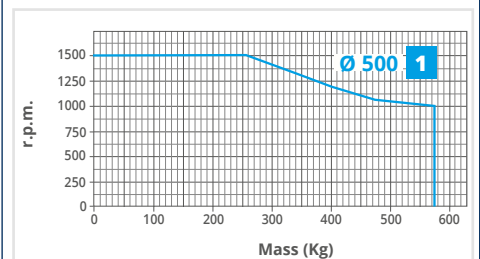

1 (*) Diagram is showing the rpm speed depending from:

- total max weight on rotary plate (fixture + workpiece).
- max overall dimension on rotary plate (fixture + workpiece) Ø 520 and 400 mm total length

ROTARY PLATE Ø650

with APS 190 and 4 APS 160 automatic operation

+3 PNEUMATIC FEEDINGS ON PALLET

Automatic or manual tooling fast set-up for Ø 650 and Ø 800 on turning workholding



Applications/Customer Benefits

- Pallet/Tooling fast set-up on turning spindles
- Tooling presence Air sensing function
- SC stroke control function
- Positioning accuracy < 0,005 mm
- **3 pneumatic feedings available on pallet**

Technical features

- Case hardened main components to assure better accuracy and long operating life
- Pneumatic opening
- Closing by spring + Turbo function
- Opening/closing automatically operated
- G6.3 balancing degree

ROTARY PLATE MODEL	ID.NO.	REPEATABILITY	CLAMPING FORCE BY TURBO AT 6 bar	MAX PRESSURE OPENING / CLOSING	AIR SENSING/ SC STROKE CONTROL PRESSURE	Ø650 PALLET MAX RPM (*)	Ø800 PALLET MAX RPM (**)	WEIGHT Kg
Ø650 AUTOMATIC +3AIR	46220440	0,005 mm	165 kN	6 bar	0,5 bar	1200	700	173

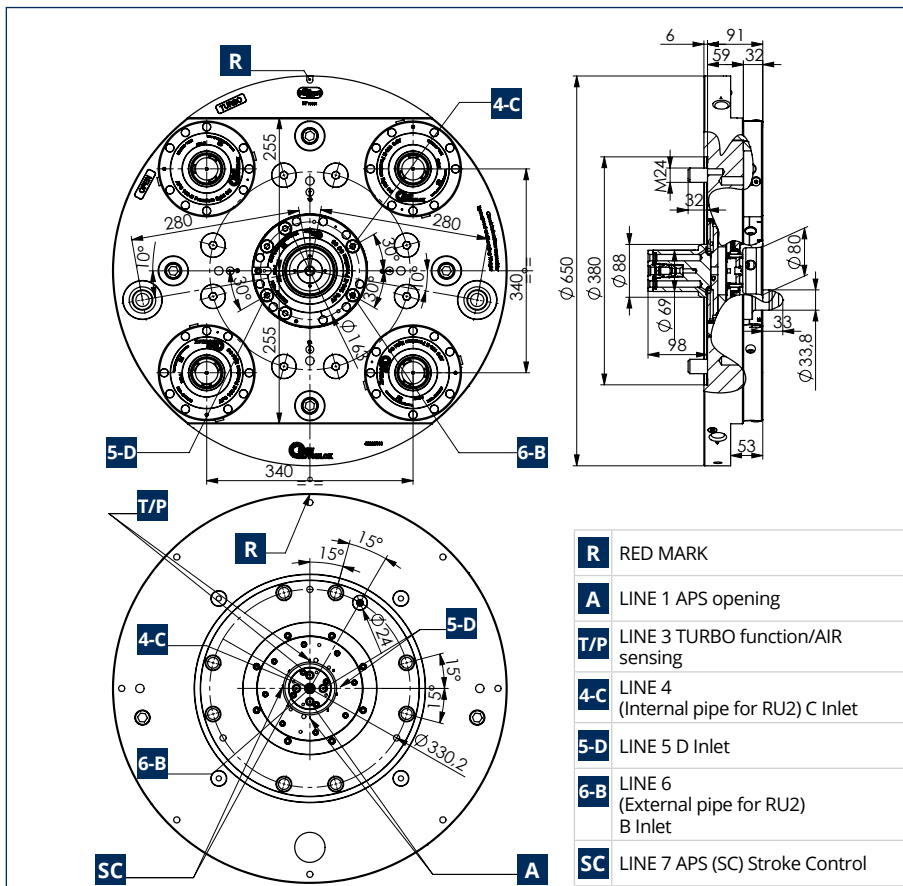

Weight/Speed diagram

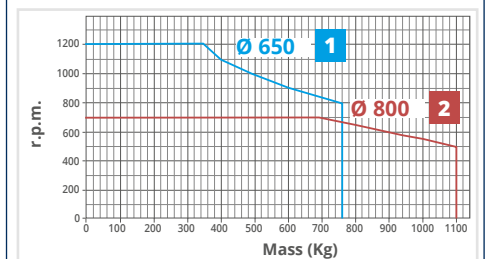

1 (*) Diagram is showing the rpm speed depending from:

- total max weight on rotary plate (fixture + workpiece).
- max overall dimension on rotary plate (fixture + workpiece) Ø 630 and 450 mm total length

2 (***) Diagram is showing the rpm speed depending from:

- total max weight on rotary plate (fixture + workpiece).
- max overall dimension on rotary plate (fixture + workpiece) Ø 630 and 450 mm total length

ROTARY PLATE ASSEMBLY LINE

for Automatic operation of APS modules+3 pneumatic feedings on pallet

Manual or automatic pallet tooling fast set-up

Special Pallet

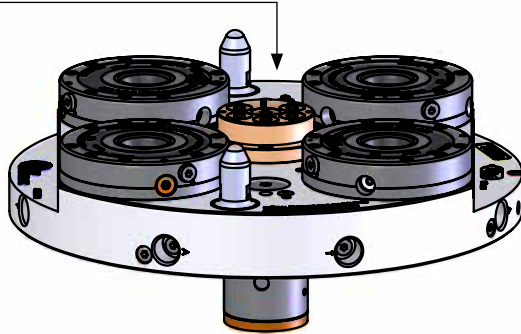

Mod. ID.No. Automatic
ROTARY PLATE
+3 pneumatic line

Ø202	46220480
Ø260	46220520
Ø330	46220380
Ø420	46220420
Ø520	46220430
Ø650	46220440

ISO-A flange [VIEW ACCESSORIES](#)

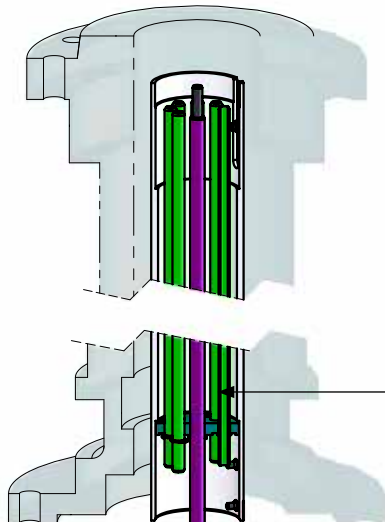

Pipe bundle

(to customize for each machine tool specifically)

Manifold flange

(to customize for each machine tool specifically)

60580010 [VIEW ACCESSORIES](#)

4-pneumatic feedings manifold

60589010

KIT RU2

PIPE BUNDLE for Automatic operation of APS modules+3 pneumatic feedings on pallet

PIPE BUNDLE assembly from ROTARY PLATE side

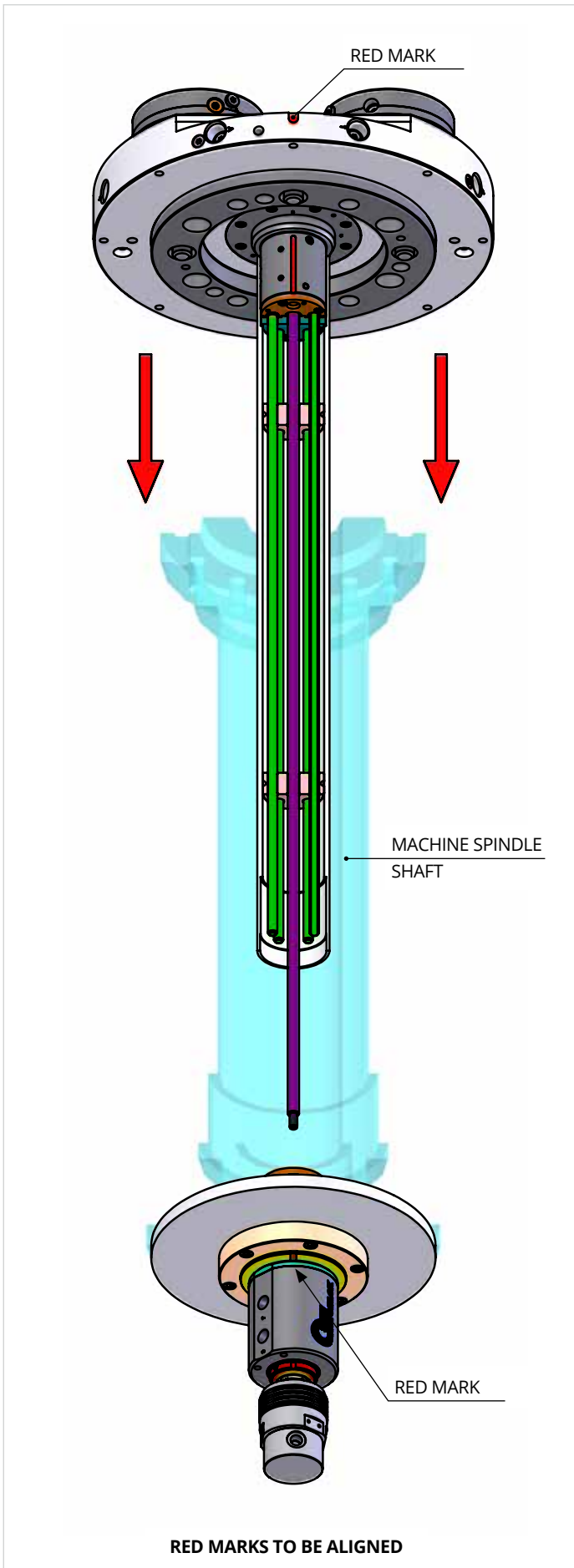

PIPE BUNDLE assembly from MANIFOLD side

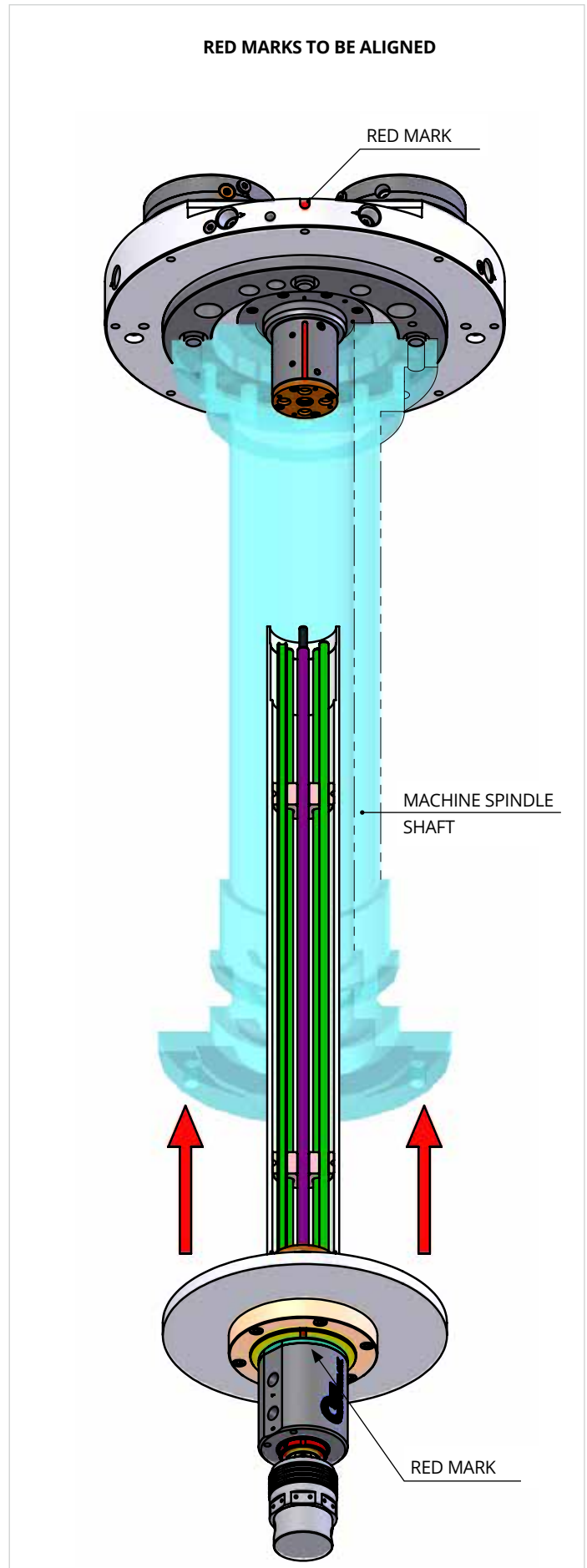

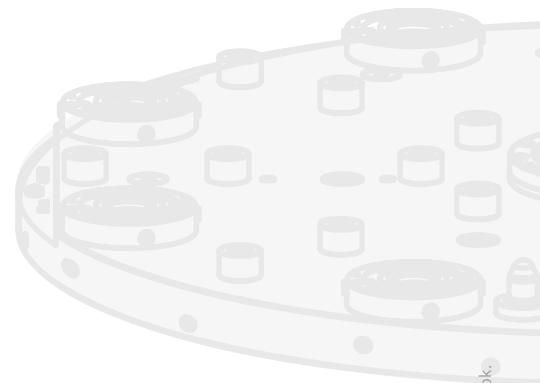
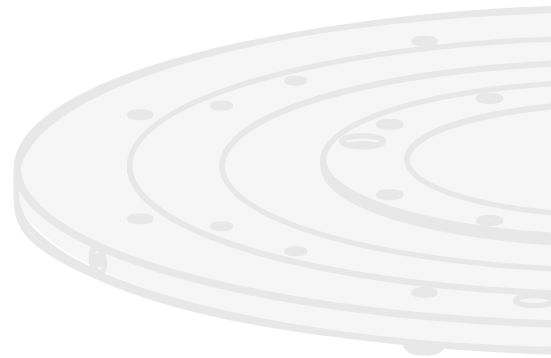
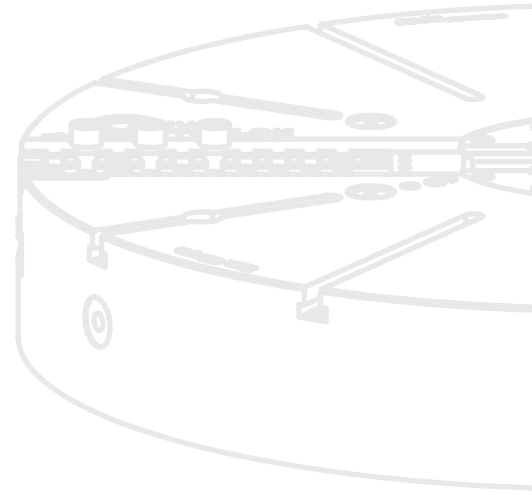

Drawings and data are subject to change by SMW-Autoblok.

ACCESSORIES

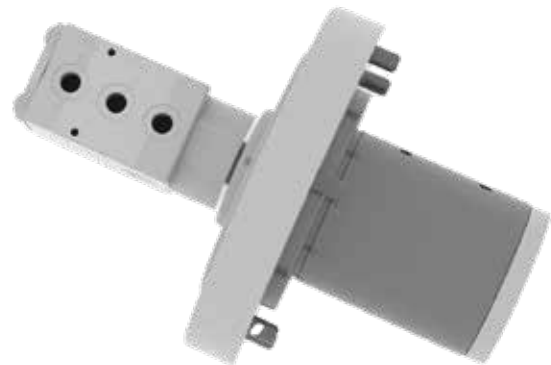

Drawings and data are subject to change by SMW-Autoblok.

PNEUMATIC ROTATING MANIFOLDS

4 PNEUMATIC Feedings ROTATING MANIFOLD to use with standard RU 2-22 rotating joint

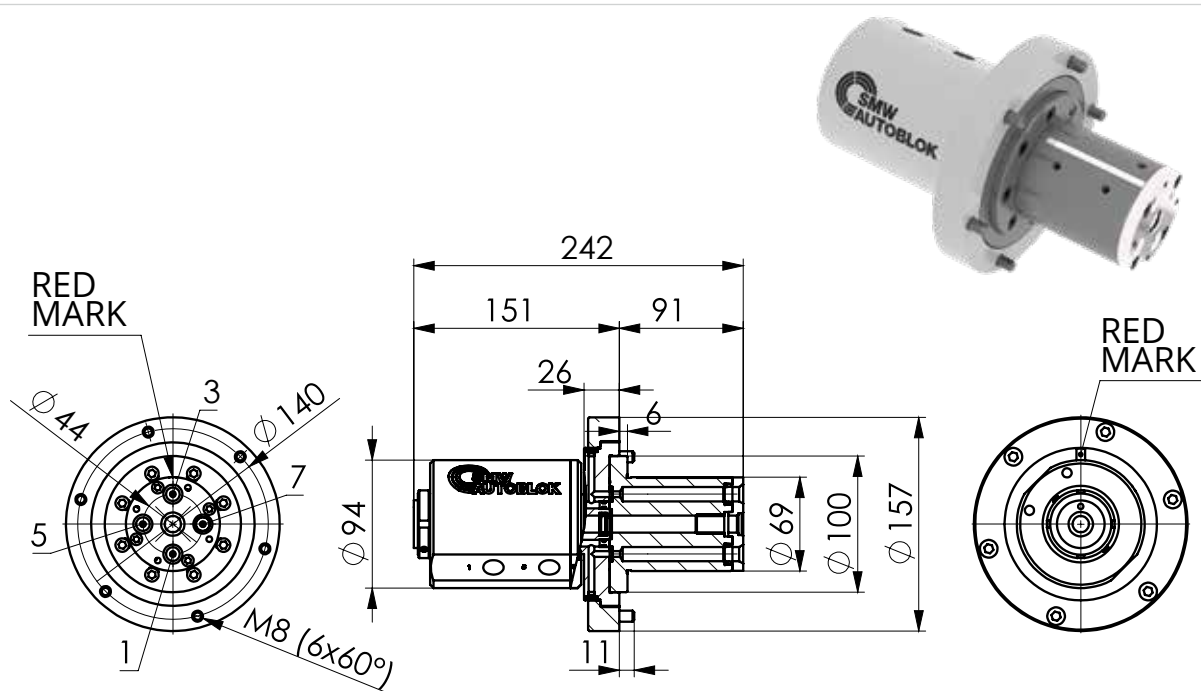

ID.NO. AND MANIFOLD MODEL	MAX PRESSURE DURING ROTATION	MAX PRESSURE DURING NO ROTATION	MAX RPM SPEED	WEIGHT
60580010 - 4 PNEUMATIC Feedings	2 bar	6 bar	1500	11 kg

3 PNEUMATIC Feedings ROTATING MANIFOLD for APS modules Automatic operation

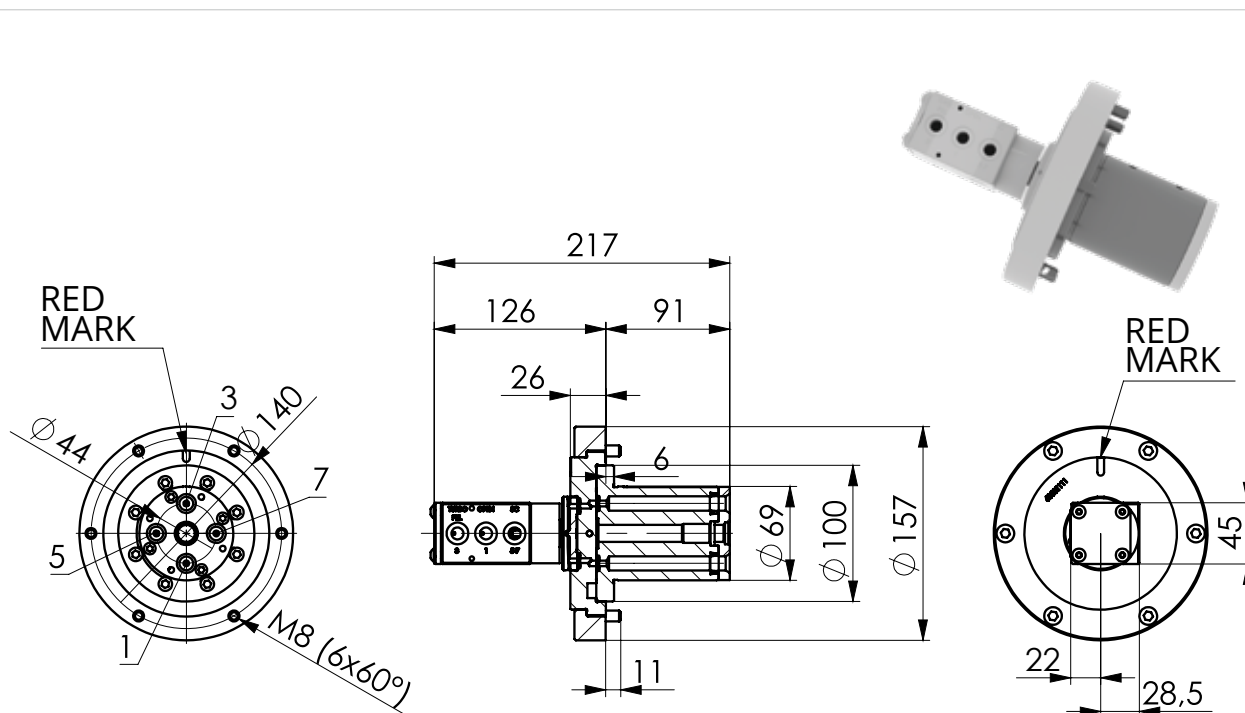

ID.NO. AND MANIFOLD MODEL	MAX PRESSURE DURING ROTATION	MAX PRESSURE DURING NO ROTATION	MAX RPM SPEED	WEIGHT
60580011 - 3 PNEUMATIC Feedings	2 bar	6 bar	3500	6,5 kg

ISO-A FLANGE FOR DIRECT CHUCK MOUNTING ON SHORT CONE MACHINE SPINDLE - DIN 55026 / ISO-A 702/1

TYPE FF1

ISO-A direct assembly

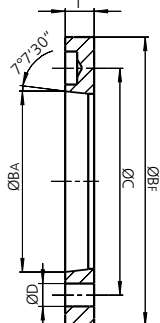

Flange ID.No.	Machine tool spindle	BF mm	BA mm	C mm	D mm	T mm	Weight kg
24162000	A6	170	106.375	133.4	13.5	17	1.5
24162500	A6	170	106.375	133.4	13.5	24	2.2
24162100	A6	170	106.375	133.4	13.5	32	3
24162110	A6	170	106.375	133.4	13.5	40	3.2
24162120	A6	170	106.375	133.4	13.5	50	4
24162160	A6	170	106.375	133.4	13.5	60	5.2
24182500	A8	220	139.719	171.4	17	19	2.7
24182510	A8	220	139.719	171.4	17	27	4
24182539	A8	220	139.719	171.4	17	39	6
24182520	A8	220	139.719	171.4	17	43	6.5
24182530	A8	220	139.719	171.4	17	51	7.5
24182565	A8	220	139.719	171.4	17	65	9.5
24182577	A8	220	139.719	171.4	17	76	11
24182590	A8	220	139.719	171.4	17	100	16
24113100	A11	300	196.869	235	21	21	5.5
24113110	A11	300	196.869	235	21	30	8
24114038	A11	300	196.869	235	21	40	10
24114030	A11	300	196.869	235	21	43	11
24114040	A11	300	196.869	235	21	65	16
24113190	A11	300	196.869	235	21	90	22
24125000	A15	380	285.775	330.2	25	23	8
24127110	A15	380	285.775	330.2	25	28	10
24127100	A15	380	285.775	330.2	25	33	11.5
24125040	A15	380	285.775	330.2	25	50	17
24125084	A15	380	285.775	330.2	25	90	33

TYPE FF2

ISO-A reduction adapting assembly

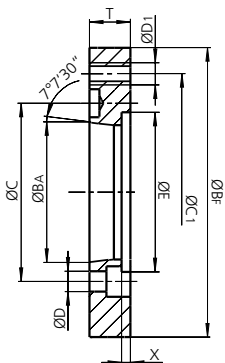

Flange ID.No.	Machine tool spindle	BF mm	BA mm	C mm	D mm	C1 mm	D1 mm	E mm	X mm	T mm	Weight kg
24152000	A5	170	82.563	104.8	11.5	133.4	M12	-	-	24	2.7
24152500	A5	220	82.563	104.8	11.5	171.4	M16	-	-	24	5.5
24162530	A6	220	106.375	133.4	13.5	171.4	M16	-	-	24	5
24162533	A6	220	106.375	133.4	13.5	171.4	M16	-	-	40	8
24162532	A6	220	106.375	133.4	13.5	171.4	M16	-	-	50	7
24162555	A6	220	106.375	133.4	13.5	171.4	M16	-	-	55	10
24163100	A6	300	106.375	133.4	13.5	235	M20	155	10	30	11
24183100	A8	300	139.719	171.4	17	235	M20	-	-	30	11.5
24184000	A8	300	139.719	171.4	17	235	M20	155	10	40	15.5
24183045	A8	300	139.719	171.4	17	235	M20	155	10	45	15.5
24183085	A8	300	139.719	171.4	17	235	M20	155	10	85	27.5
24185000	A8	380	139.719	171.4	17	330.2	M24	197	10	40	24
24115000	A11	380	196.869	235	21	330.2	M24	197	10	40	21
24115020	A11	380	196.869	235	21	330.2	M24	197	10	56	27
24179400	A20	720	412.775	463.6	27	647.6	M30	-	-	50	93

TYPE FF3

ISO-A increasing adapting assembly

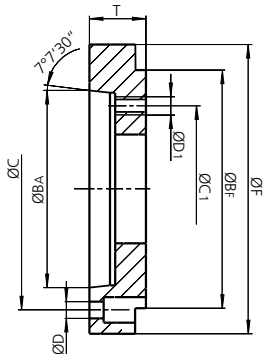

Flange ID.No.	Machine tool spindle	BF mm	BA mm	C mm	D mm	C1 mm	D1 mm	F mm	T mm	Weight kg
24182010	A8	170	139.719	171.4	17	133.4	M12	210	40	6.2
24182110	A8	170	139.719	171.4	17	133.4	M12	210	56	8
24182170	A8	170	139.719	171.4	17	133.4	M12	210	70	8.5
24112540	A11	220	196.869	235	21	171.4	M16	280	40	10
24112510	A11	220	196.869	235	21	171.4	M16	280	45	11.8
24112520	A11	220	196.869	235	21	171.4	M16	280	55	13
24112565	A11	220	196.869	235	21	171.4	M16	280	65	15.5
24112570	A11	220	196.869	235	21	171.4	M16	280	70	18
24112580	A11	220	196.869	235	21	171.4	M16	280	85	19
24123110	A15	300	285.775	330.2	25	235	M20	380	50	22
24123175	A15	300	285.775	330.2	25	235	M20	380	75	29
24175000	A20	380	412.777	463.6	27	330.2	M24	520	58	55

MAGNET PROTECTION COVERS for APS

USE IN ROTATION ONLY WITH CLOSED APS

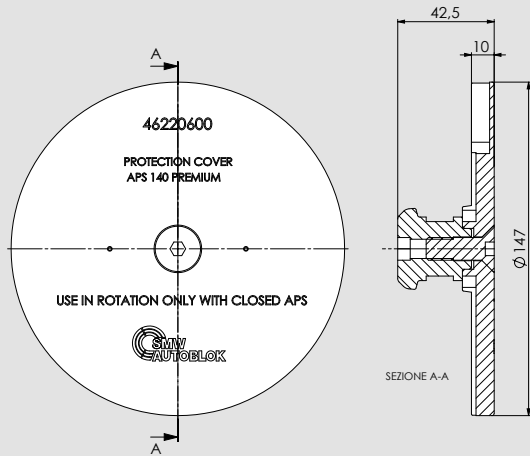

USE IN ROTATION ONLY WITH CLOSED APS

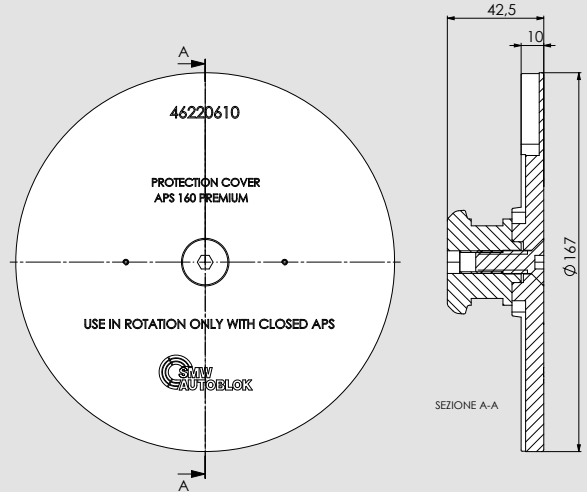

ID.No.	MODEL (APS IN ROTATION)	Weight
46220600	MAGNET PROTECTION COVER FOR APS 140 PREMIUM	0.65 Kg

ID.No.	MODEL (APS IN ROTATION)	Weight
46220610	MAGNET PROTECTION COVER FOR APS 160 PREMIUM	0.9 Kg

USE IN ROTATION ONLY WITH CLOSED APS

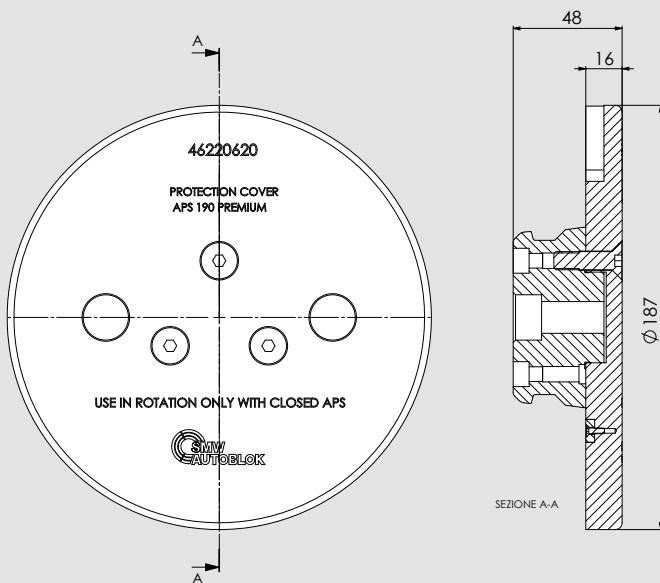

USE IN ROTATION ONLY WITH CLOSED APS

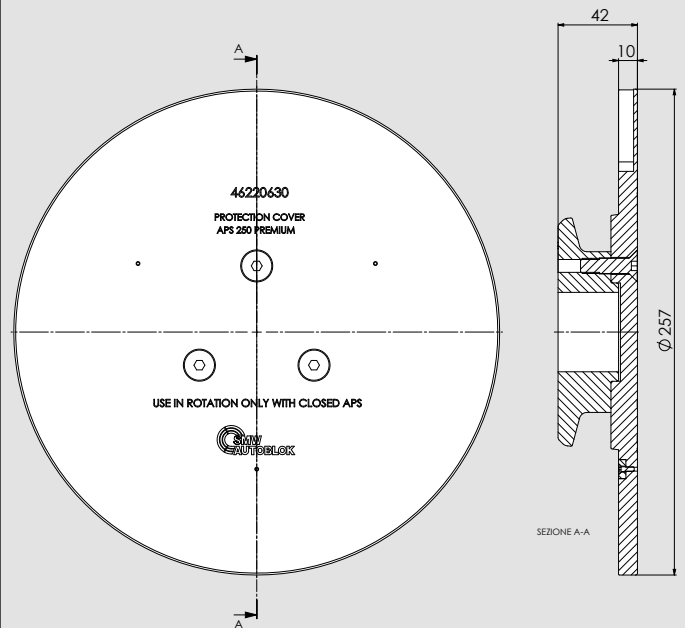

ID.No.	MODEL (APS IN ROTATION)	Weight
46220620	MAGNET PROTECTION COVER FOR APS 190 PREMIUM	2.2 Kg

ID.No.	MODEL (APS IN ROTATION)	Weight
46220630	MAGNET PROTECTION COVER FOR APS 250 PREMIUM	2.9 Kg

Drawings and data are subject to change by SMW-Autoblok.

4

AT-PM Quick Chucks Change System

92

AT-PM 200/170

Quick chucks change on lathe.
CHUCKS Ø170 Ø210 Ø260

93

AT-PM 240/220

Quick chucks change on lathe.
CHUCKS Ø210 Ø260 Ø315

94

AT-PM 320/330

Quick chucks change on lathe.
CHUCKS Ø315 Ø400 Ø530

96

USING EXAMPLE

Expanding mandrels and self-centering chucks
usable on AT-PM.

98

DOUBLE PISTON CYLINDERS

With 4 safety valves for AT-PM control

4

AT-PM

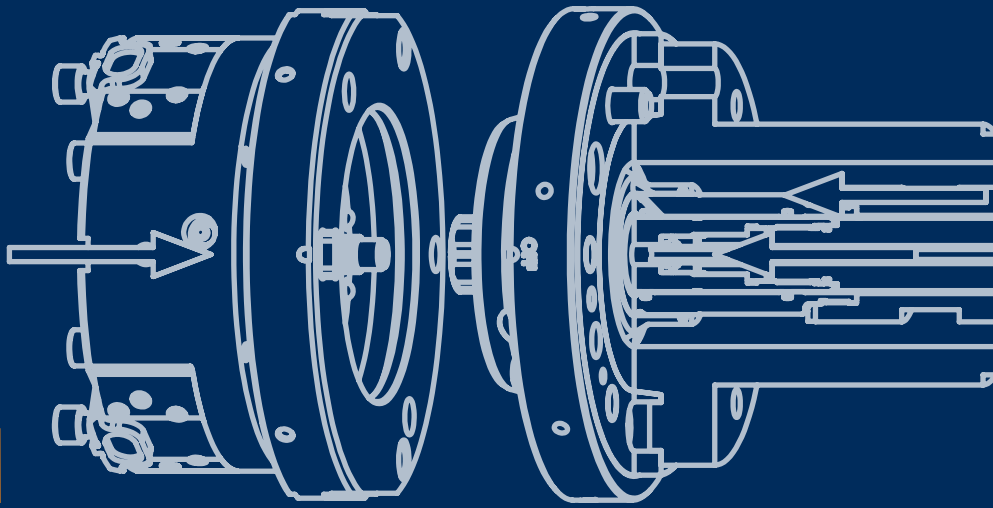

All SMW-Autoblok quick chucks change systems are designed to permit a fast and quick change of chucks on the lathe using a special double cylinder.

CUSTOMER BENEFITS

- ▶ QUICK CHUCKS CHANGE ON LATHE
- ▶ QUICK CHUCKS CHANGE AVAILABLE DIAMETER ON LATHE
- ▶ QUICK CONNECTION TO DOUBLE CYLINDER BETWEEN AUTOMATIC FEEDING
- ▶ PALLET POSITIONING ACCURACY
PALLET < 0,005 mm

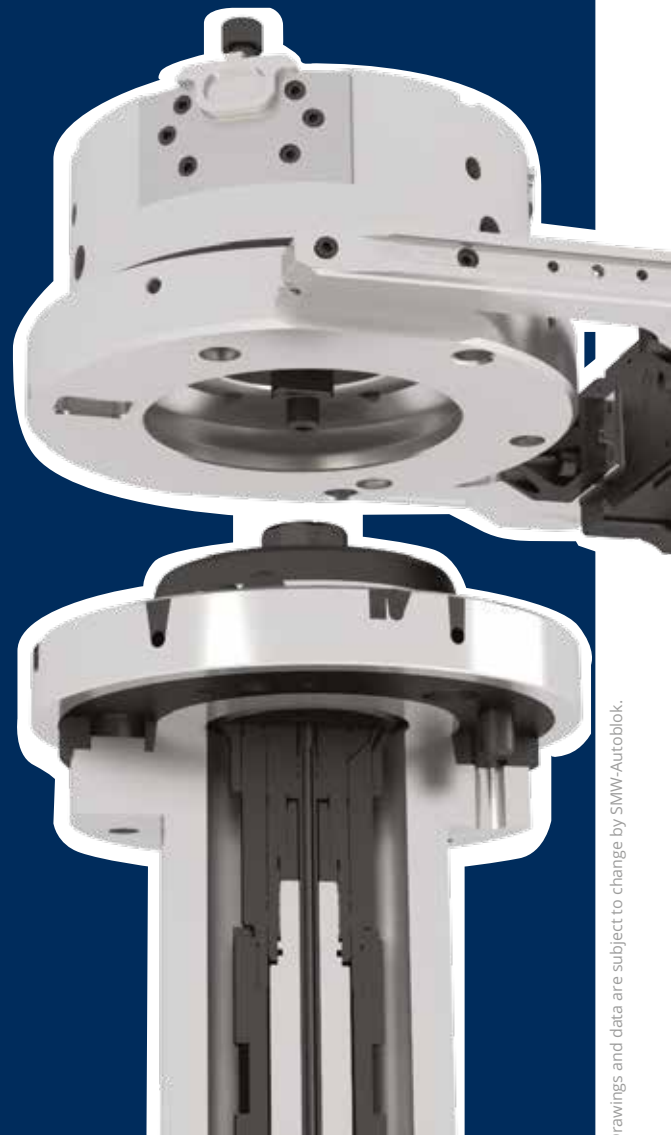

Drawings and data are subject to change by SMW-Autoblok.

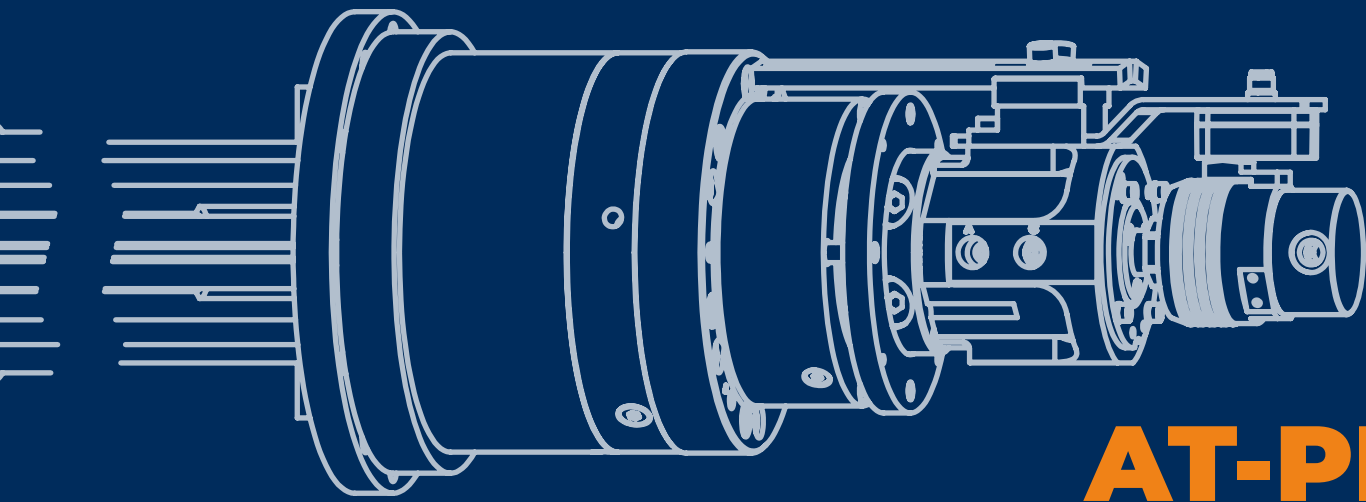

AT-PM

Product type	Size			AT-PM Id. n.	pallets and chucks usable on rotary plate		Air sensing	external draw-bar/operation AT-PM		internal draw-bar/operation CHUCK OR COLLECT	
	200/170	240/220	320/330		∅ pallets /chucks	rpm		max pull-down cylinder	max holding force pallet	max pull-down force cylinder	max pushing force cylinder
ATPM	200/170			65002009	170	5000		30 kN	120 kN	68 kN	40 kN
					210	4000					
					260	3000					
		240/220		65002405	210	4500		30 kN	120 kN	68 kN	40 kN
					260	3500					
					315	2500					
			320/330	65003205	315	2500		40 kN	160 kN	112 kN	65 kN
					400	1600					
					530	900					

DOUBLE PISTON CYLINDERS with 4 safety valves AT-PM control

CUSTOMER BENEFITS

AT-PM actuation +TS and AP chucks

AT-PM actuation + collets

Pallet positioning accuracy < 0,005 mm

PISTON 1

 AT-PM actuation

PISTON 2

 Chuck actuation

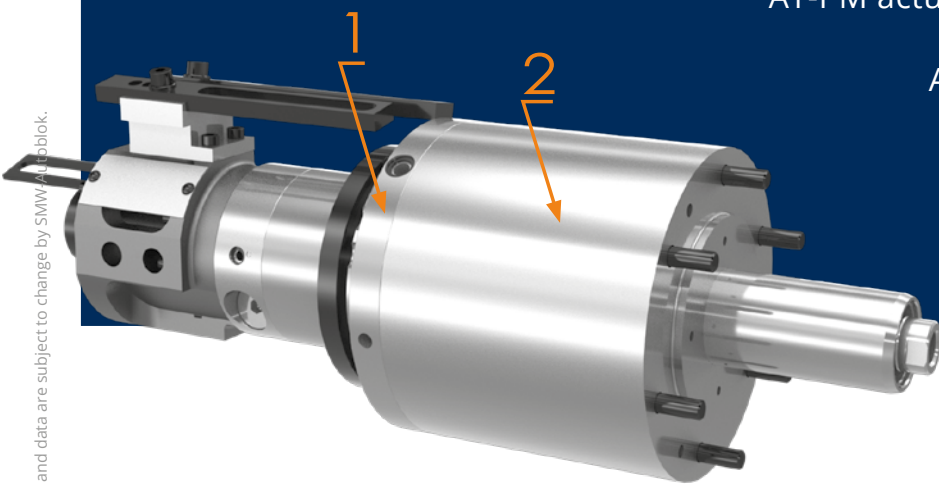

Drawings and data are subject to change by SMW-AUTOBLOK.



AT-PM 200/170

AUTOMATIC CHUCK CHANGE SYSTEM

CHUCKS: Ø170 Ø210 Ø260

Applications/Customer benefits

- Quick chucks change on lathe
- Quick chucks change Ø170 Ø210 Ø250 available diameter on lathe, quick connection to double cylinder between automatic feeding
- Pallet positioning accuracy pallet < 0,005 mm

Technical features

- Hardened materials for high accuracy and durability
- AT-PM operation with hydraulic double cylinder
- Air sensing function for pallet positioning
- Balancing 6.3

AT-PM MODEL	ID.NO.	REPEATABILITY	Ø170 CHUCK MAX RPM	Ø210 CHUCK MAX RPM	Ø260 CHUCK MAX RPM	WEIGHT Kg	EXTERNAL DRAW-BAR/ ACTUATION AT-PM		INTERNAL DRAW-BAR/ ACTUATION CHUCK OR COLLECT	
							MAX PULL-DOWN CYLINDER	MAX HOLDING FORCE PALLET	MAX PULL-DOWN FORCE CYLINDER	MAX PUSHING FORCE CYLINDER
Ø200/170 A6	65002009	0,005 mm	5000	4000	3000	12,5	30 kN	120 kN	68 kN	40 kN

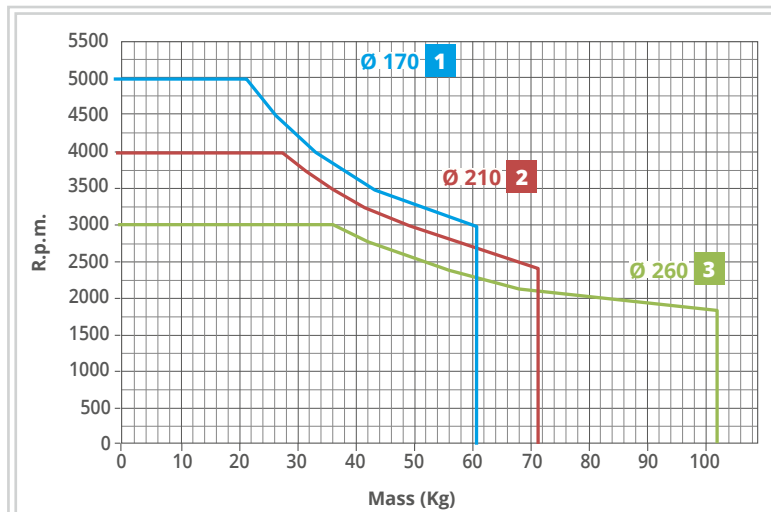

1 (*) Diagram is showing the rpm speed depending from:
 - total max weight (pallet + chuck or fixture + workpiece).
 - max overall dimension Ø 170 and 190 mm total length

2 (**) Diagram is showing the rpm speed depending from:
 - total max weight (pallet + chuck or fixture + workpiece).
 - max overall dimension Ø 210 and 220 mm total length

3 (***) Diagram is showing the rpm speed depending from:
 - total max weight (pallet + chuck or fixture + workpiece).
 - max overall dimension Ø 250 and 250 mm total length

(*) (**) (***) rpm max speed has to be reduced if used the chuck type has a lower rpm speed

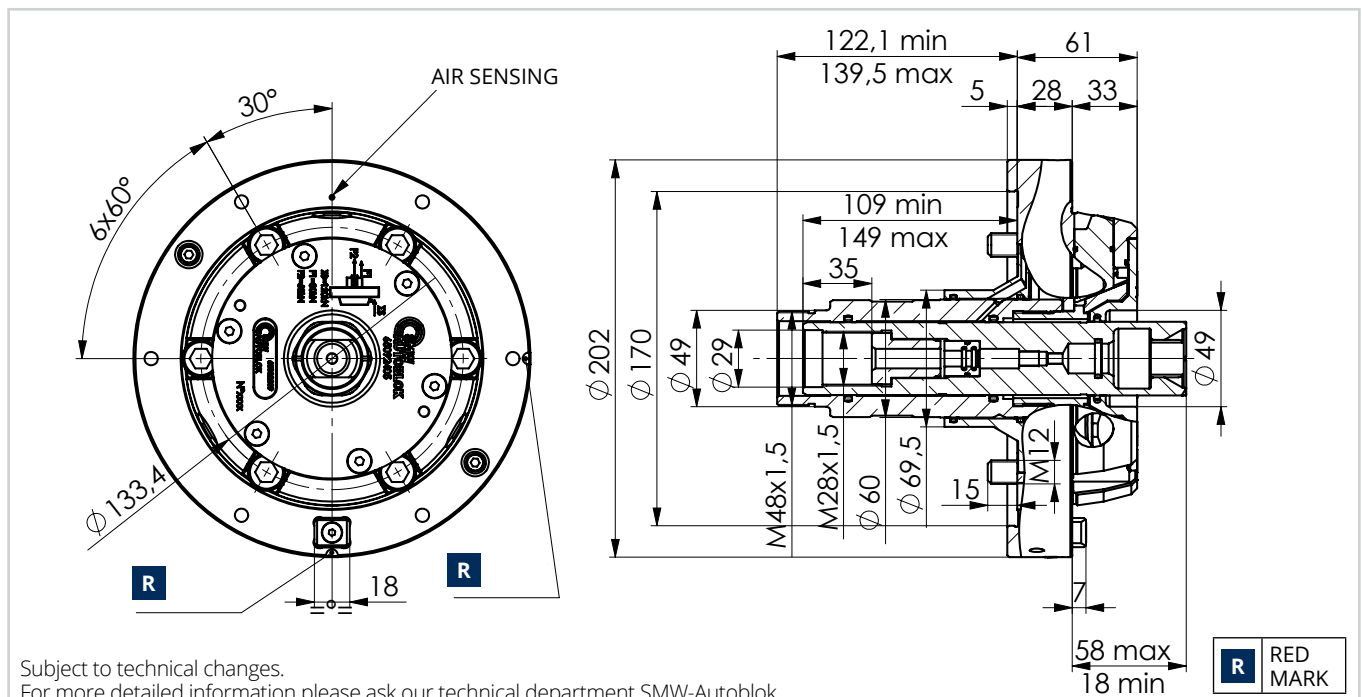

Drawings and data are subject to change by SMW-Autoblok.

AT-PM 240/220

AUTOMATIC CHUCK CHANGE SYSTEM

CHUCKS: Ø210 Ø260 Ø315

Applications/Customer benefits

- Quick chucks change on lathe
- Quick chucks change Ø210 Ø250 Ø315 available diameter on lathe, quick connection to double cylinder between automatic feeding
- Pallet positioning accuracy pallet < 0,005 mm

Technical features

- Hardened materials for high accuracy and durability
- AT-PM operation with hydraulic double cylinder
- Air sensing function for pallet positioning
- Balancing 6.3

AT-PM MODEL	ID.NO.	REPEATABILITY	Ø210 CHUCK MAX RPM	Ø260 CHUCK MAX RPM	Ø315 CHUCK MAX RPM	WEIGHT Kg	EXTERNAL DRAW-BAR/ ACTUATION AT-PM		INTERNAL DRAW-BAR/ ACTUATION CHUCK OR COLLECT	
							MAX PULL-DOWN CYLINDER	MAX HOLDING FORCE PALLET	MAX PULL-DOWN FORCE CYLINDER	MAX PUSHING FORCE CYLINDER
Ø240/220 A8	65002405	0,005 mm	4500	3500	2500	16	30 kN	120 kN	68 kN	40 kN

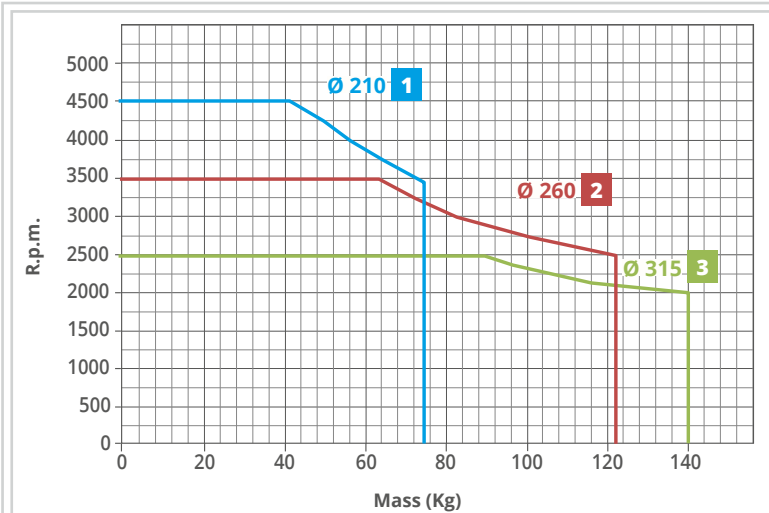

- (*) Diagram is showing the rpm speed depending from:
 - total max weight (pallet + chuck or fixture + workpiece).
 - max overall dimension Ø 210 and 220 mm total length
- (**) Diagram is showing the rpm speed depending from:
 - total max weight (pallet + chuck or fixture + workpiece).
 - max overall dimension Ø 250 and 250 mm total length
- (***) Diagram is showing the rpm speed depending from:
 - total max weight (pallet + chuck or fixture + workpiece).
 - max overall dimension Ø 315 and 250 mm total length

(*) (**) (***) rpm max speed has to be reduced if used the chuck type has a lower rpm speed

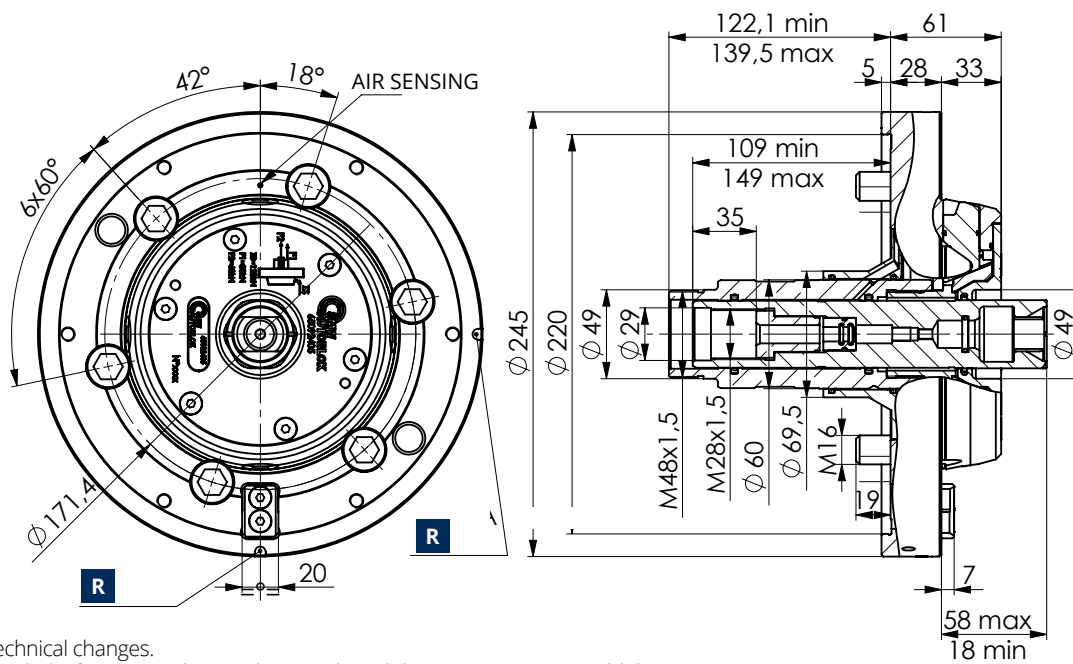

Subject to technical changes.
For more detailed information please ask our technical department SMW-Autoblok.

AT-PM 320/300

AUTOMATIC CHUCK CHANGE SYSTEM

CHUCKS: Ø315 Ø400 Ø530

Applications/Customer benefits

- Quick chucks change on lathe
- Quick chucks change Ø315 Ø400 Ø530 available diameter on lathe, quick connection to double cylinder between automatic feeding
- Pallet positioning accuracy pallet < 0,005 mm

Technical features

- Hardened materials for high accuracy and durability
- AT-PM operation with hydraulic double cylinder
- Air sensing function for pallet positioning
- Balancing 6.3

AT-PM MODEL	ID.NO.	REPEATABILITY	Ø315 CHUCK MAX RPM	Ø400 CHUCK MAX RPM	Ø530 CHUCK MAX RPM	WEIGHT Kg	EXTERNAL DRAW-BAR/ ACTUATION AT-PM		INTERNAL DRAW-BAR/ ACTUATION CHUCK OR COLLECT	
							MAX PULL-DOWN CYLINDER	MAX HOLDING FORCE PALLET	MAX PULL-DOWN FORCE CYLINDER	MAX PUSHING FORCE CYLINDER
Ø320/300 A11	65003205	0,005 mm	2500	1600	900	32	40 kN	160 kN	112 kN	65 kN

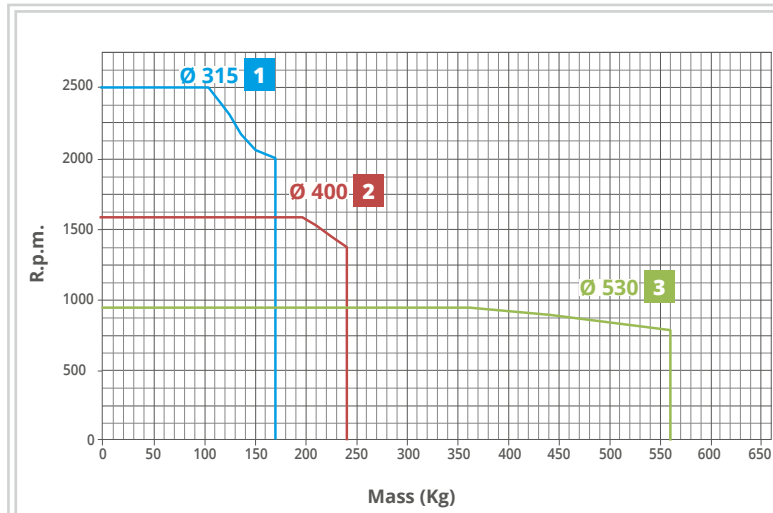

- 1 (*) Diagram is showing the rpm speed depending from:
 - total max weight (pallet + chuck or fixture + workpiece).
 - max overall dimension Ø 315 and 250 mm total length
- 2 (**) Diagram is showing the rpm speed depending from:
 - total max weight (pallet + chuck or fixture + workpiece).
 - max overall dimension Ø 420 and 300 mm total length
- 3 (***) Diagram is showing the rpm speed depending from:
 - total max weight (pallet + chuck or fixture + workpiece).
 - max overall dimension Ø 520 and 400 mm total length

(*) (**) (***) rpm max speed has to be reduced if used the chuck type has a lower rpm speed

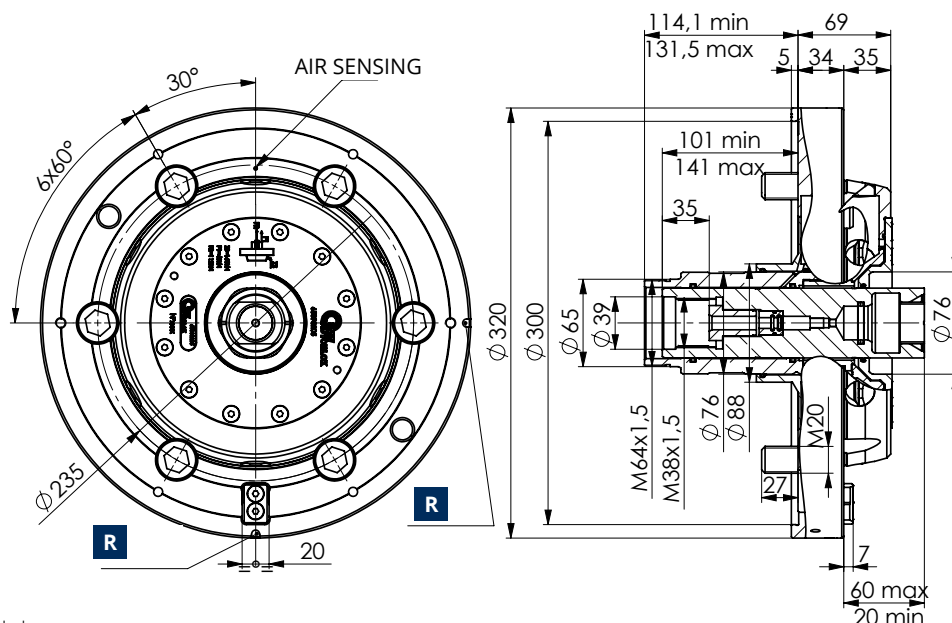

Subject to technical changes.
For more detailed information please ask our technical department SMW-Autoblok.



PALLET FOR QUICK CHUCKS CHANGE SYSTEM AT-PM

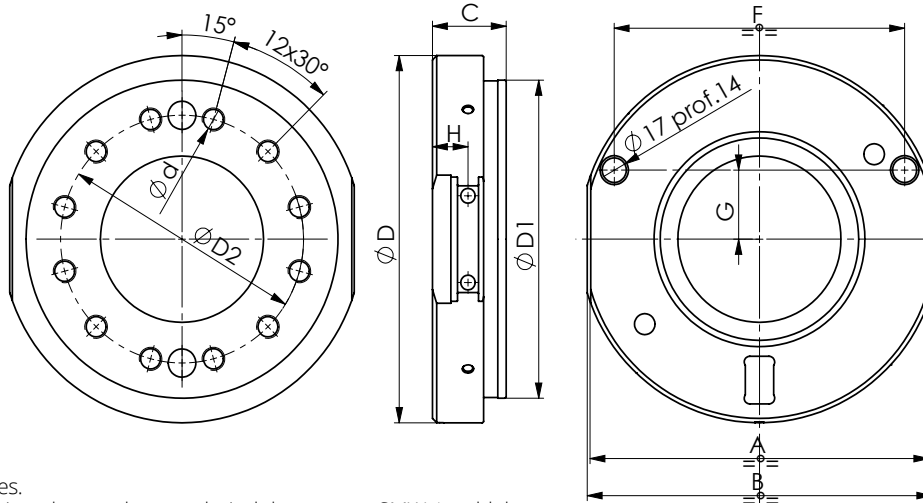

Subject to technical changes.
For more detailed information please ask our technical department SMW-Autoblok.

AT-PM MODEL	PALLET ID.No.	$\varnothing D$ pallet mm	$\varnothing D_1$ mm	$\varnothing D_2$ mm	$\varnothing d$ mm	A mm	B mm	C mm	F mm	G mm	H mm	Weight kg
AT-PM 200/170	65622009	206	140	104,8	M10	190	194	54	166,8	38,9	25	6,6
AT-PM 200/170	65612009	206	170	133,4	M12	190	194	52	166,8	38,9	25	6,3
AT-PM 200/170	65632009	206	220	171,4	M16	190	194	52	166,8	38,9	25	6,8
AT-PM 240/220	65622405	254	170	133,4	M12	239	243	52	204,8	47,8	25	11,8
AT-PM 240/220	65612405	254	220	171,4	M16	239	243	52	204,8	47,8	25	12
AT-PM 320/300	65623205	325	220	171,4	M16	304	308	59	262,8	61,3	25	20
AT-PM 320/300	65613205	325	300	235	M20	304	308	54	262,8	61,3	25	18,7
AT-PM 320/300	65633205	378	380	330,2	M24	345	349	55	262,8	61,3	25	31

PALLET SMF

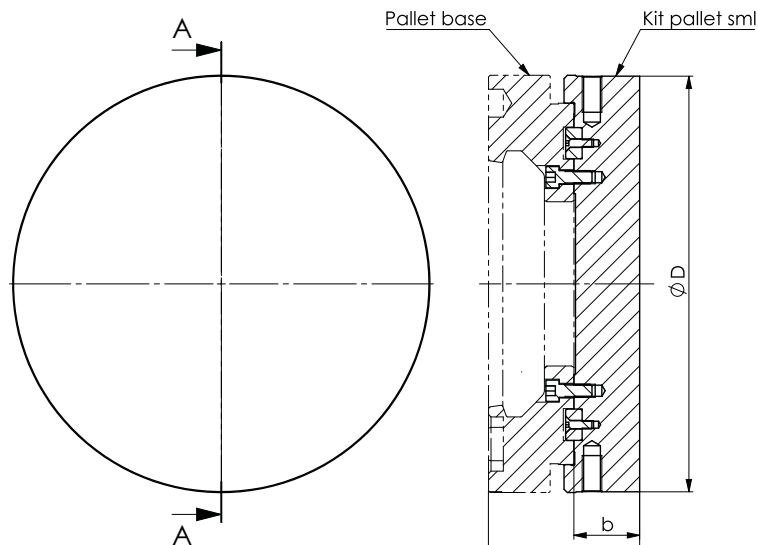

Subject to technical changes.
For more detailed information please ask our technical department SMW-Autoblok.

AT-PM MODEL	ID.No. KIT PALLET SMF	ID.No. PALLET BASE	$\varnothing D$ mm	b mm	b1 mm	Weight kg
AT-PM 200/170	65502009	65632009	254	40	92	16,5
AT-PM 240/220	65502009	65612405	254	40	92	16,5
AT-PM 320/300	65503205	65613205	354	40	94	32

EXAMPLE OF EXPANDING MANDRELS USABLE ON AT-PM
ask more details to SMW-Autoblok technical office department

EM-A model
pull-down
expanding mandrels



personalized
connection

EM-B model
expanding mandrels



personalized
connection

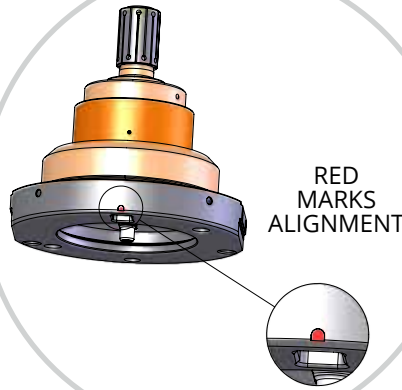

RED
MARKS
ALIGNMENT



personalized
connection



personalized
connection

EM-AL model
pull-down expanding
mandrels-body lengthened

KSZ-AZ model
draw collet chucks

EXAMPLE OF SELF-CENTERING CHUCKS USABLE ON AT-PM
watch the video using QR code

STEP1



STEP2



STEP3



STEP4



DOUBLE PISTON CYLINDERS

WITH 4 SAFETY VALVES FOR AT-PM CONTROL

Applications/Customer benefits

- AT-PM actuation +TS and AP chucks
- AT-PM actuation + collets
- Pallet positioning accuracy < 0,005 mm

Technical features

- Double piston cylinder with 4 way oil manifold for separate actuation of the 2 cylinders
- Pressure range 8 - 70 bar
- Horizontal or vertical installation
- Safety valves on the biggest cylinders and stroke control on each cylinder
- Central bore for air, coolant or oil with thread for rotary union
- Mounting from the rear side with bolts
- A 10 µm filter in pressure line is requested
- Use oil HM32 ISO 3448
- Air sensing function for pallet positioning
- Balancing 6.3

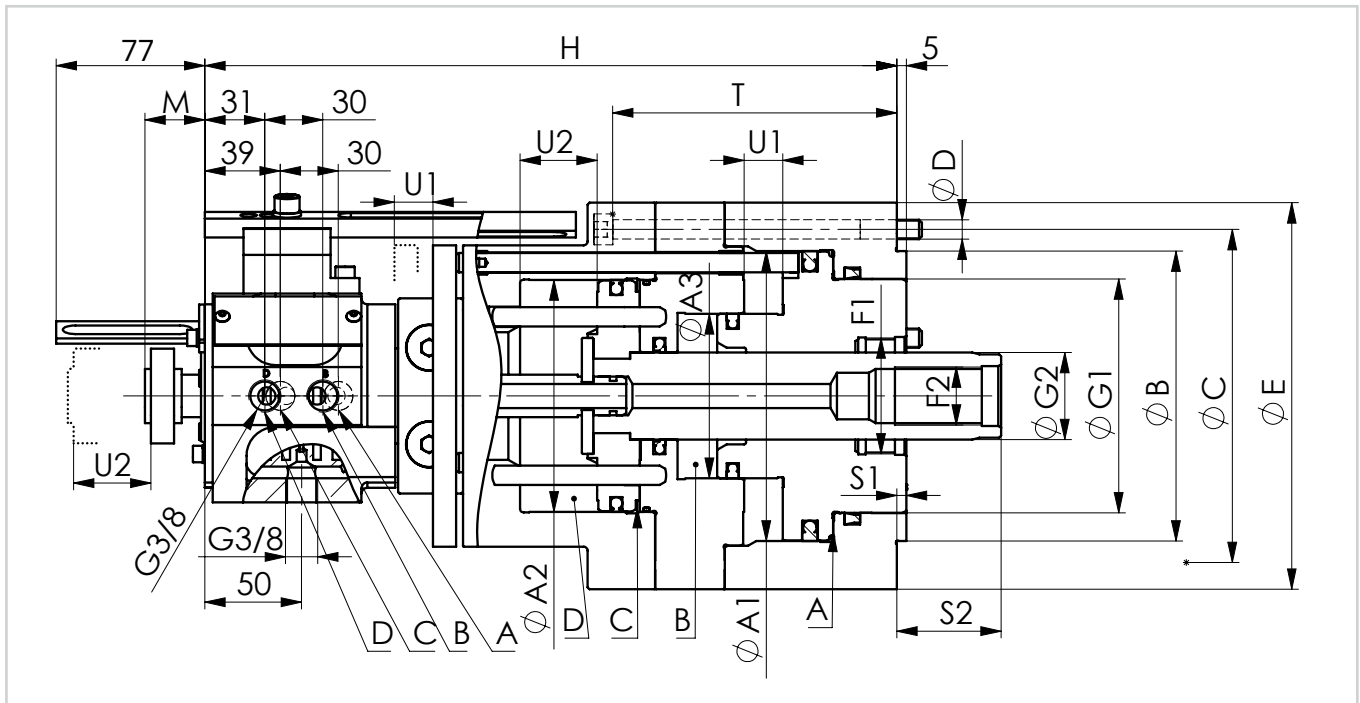

ID.No.	DOUBLE PISTON CYLINDER TYPE	Piston Area A (cm ²)	Piston Area B (cm ²)	Piston Area C (cm ²)	Piston Area D (cm ²)	A Piston force max/min (kN)	B Piston force max/min (kN)	C Piston force max/min (kN)	D Piston force max/min (kN)	Max speed (rpm)	Weight (kg)	Moment of inertia (kgm ²)	Pressure max/min (bar)
33981009	DCE-4V 64-64/30-40	66	63	63	66	46/5	44/5	44/5	46/5	5000	28,6	0,074	70/8
33981206	DCR-4V 60-100/20-40	61	41	97	109	43/5	29/3,3	68/7,7	76/8,7	5000	36	0,127	70/8
33981510	DCR-4V 90-160/20-40	90	41	160	173	63/7	29/3,3	112/13	121/14	4000	47,5	0,24	70/8

Total oil drainage 3 dm³/min at 30 bar /50°C

ID.No.	DOUBLE PISTON CYLINDER TYPE	A1	A2	A3	B	C	D 6x60°	E	F1	F2	G1	G2	H	M	S1 (max)	S2 (max)	T	U1	U2
33981009	DCE-4V 64-64/30-40	125	95	/	105	145	M10	174	M45x1,5	M20x1,5	85	30	362	31	40	76	151	30	40
33981206	DCR-4V 60-100/20-40	150	120	85	150	175	M10	200	M60x1,5	M30	121	45	358	31	5	54	147	20	40
33981510	DCR-4V 90-160/20-40	180	150	85	180	206	M12	234	M72x1,5	M30	145	45	360	31	5	52	144	20	40

AT-PM: Double piston cylinders and LPS 4.0 kit

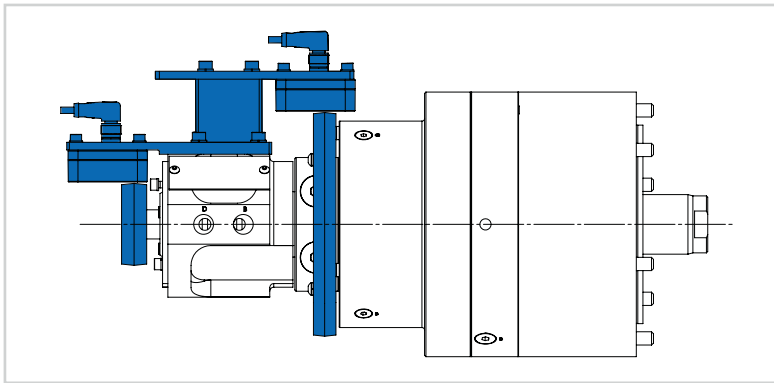
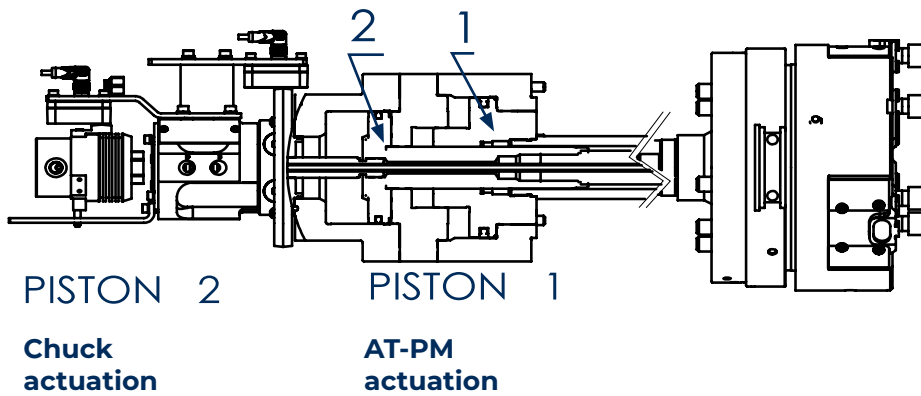

LPS 4.0 Kit - OPTIONAL

- kit for DCE-4V 64/64 ID.No. 60558306
- kit for DCR-4V 60/100 ID.No. 60558406
- kit for DCR-4V 90/160 ID.No. 60558407

Not included in the kit:

- sensor LPS 4.0 ID.No. 208108
- cable+connector ID.No. 208247

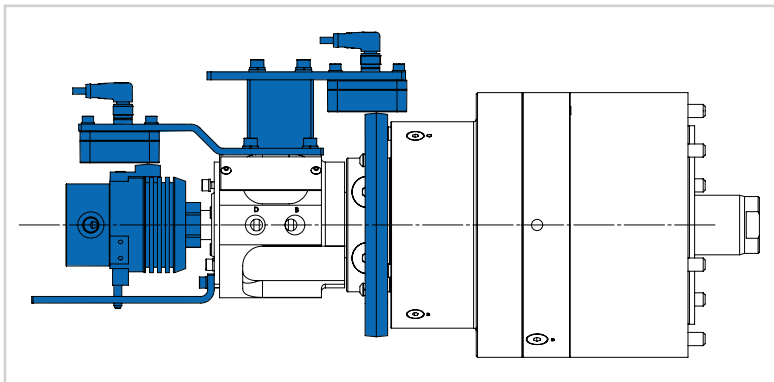

LPS 4.0 Kit - RU-2-22 - OPTIONAL

- kit for DCE-4V 64/64 ID.No. 60558336
- kit for DCR-4V 60/100 ID.No. 60558436
- kit for DCR-4V 90/160 ID.No. 60558437

Not included in the kit:

- sensor LPS 4.0 ID.No. 208108
- cable+connector ID.No. 208247
- rotary union for 2 media type RU-2-22 ID.No. 044970

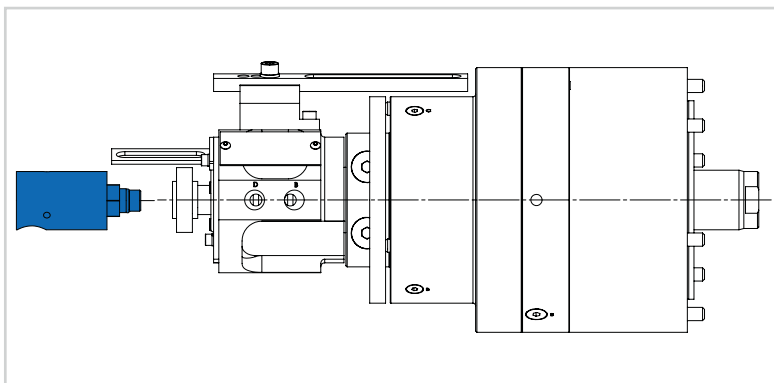

Rotary union RU-1-16 - OPTIONAL

- rotary union for 1 medium RU-1-16 ID.No. 043271

QUICK CHUCKS CHANGE SYSTEM AT-PM

pallet connecting instructions

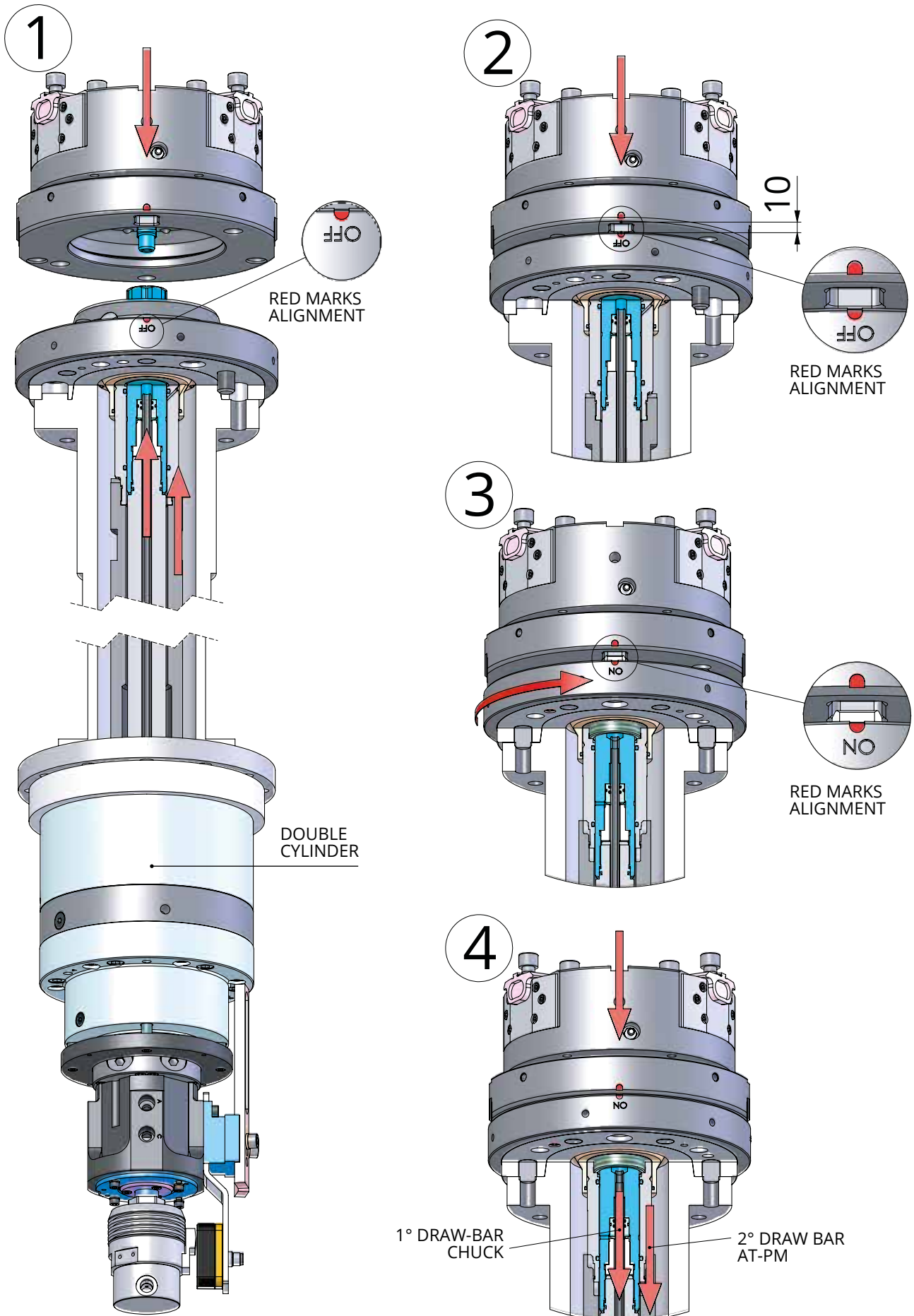

5

ONE APS PALLET and MULTIPLE CLAMPING PALLET



102

Semifinished PALLET

Prepared for robot loading

112

MULTIPLE Clamping PALLET

With 2 APS 140

Prepared for robot or manual loading

102

PALLET for chucks

DIN6350

Prepared for robot loading

113

MULTIPLE Clamping PALLET

With 4 APS 140

Prepared for robot or manual loading

103

PALLET for chucks

HG-N

Prepared for robot loading

114

MULTIPLE Clamping PALLET

With 6 APS 140

Prepared for robot or manual loading

104

Manual vises PALLET holder

Prepared for robot loading

115

MULTIPLE Clamping PALLET

Pallet prepared for self-centering assembly without and with feedings for grippers

105

Two parts PALLET

Prepared for robot loading

119

MACHINE SOLUTIONS

3-5 AXIS

Upper plate manual change or by robot

106

PALLET 88

Prepared for robot loading

107

STV PALLET holder

With SAB-1 STANDARD ZERO FEEDINGS

Prepared for robot loading

108

180 STV PALLET holder

With 2-4 FEEDINGS

Prepared for robot loading

109

MACHINE SOLUTIONS

5 AXIS

Upper plate manual change or by robot

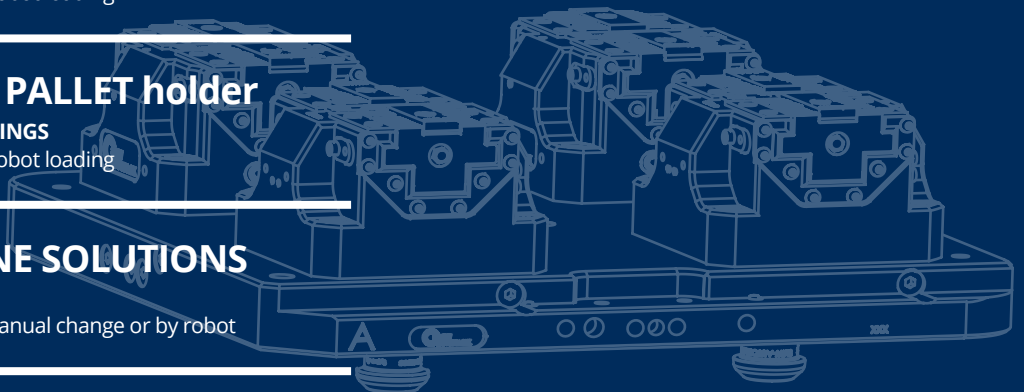

5.1 ROUND SEMIFINISHED PALLET prepared for robot loading

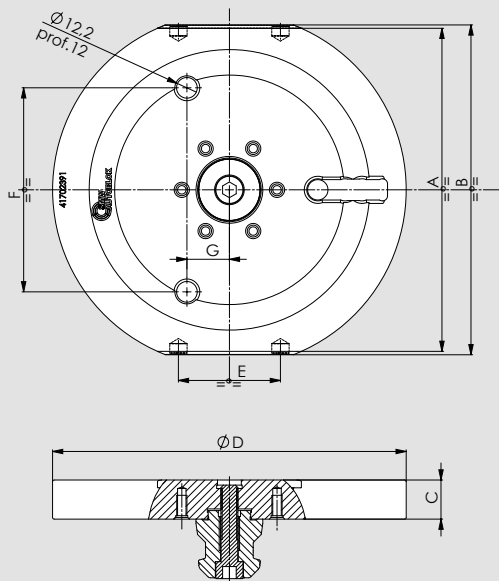

Induction-hardened material

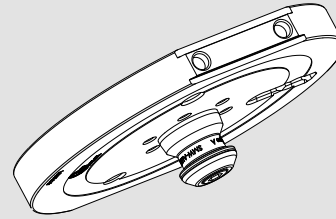

The pallets are prepared for handling with robot using the PP-L and PL-L grippers (refer to the grippers chapters).

MODULE	ID.N.	PALLET Ø D	A	B	C	E	F	G	FINGERS KIT 160 PP-L PL-L GRIPPERS	FINGERS KIT 200 PP-L PL-L GRIPPERS	Kg
100 APS	46200000	130	115	119	23	40	90	25	46204010		2,3
140 APS	46200005	166	150	154	23	50	120	25	46204020		4
140 APS	46200010	208	190	194	23	60	120	25	46204030	46204050	6
190 APS	46200015	208	190	194	23	60	120	25	46204030	46204050	6,8
190 APS	46200020	260	240	244	23	60	120	25		46204040	10,2

5.2 PALLET FOR CHUCKS DIN6350 prepared for robot loading

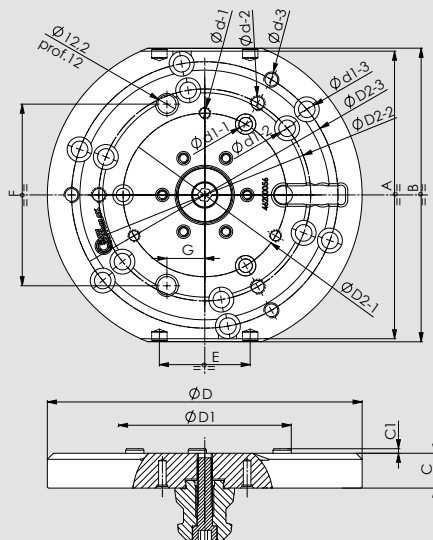

Hardened and tempered material

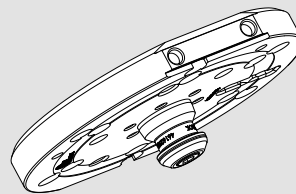

The pallets are prepared for handling with robot using the PP-L and PL-L grippers (refer to the grippers chapters).

MOD.	ID.N. without chuck	PALLET Ø D	Ø D1-1	Ø D1-2	Ø D1-3	Ø D2-1	Ø D2-2	Ø D2-3	Ø d-1	Ø d-2	Ø d-3	Ø d1-1	Ø d1-2	Ø d1-3	A	B	C	C1	E	F	G	Kg
100 APS	46200030	133	94,9	-	-	108	-	-	3xM8	-	-	3xØ9	-	-	118	122	25	3	40	90	25	2,5
140 APS	46200035	172	94,9	124,9	-	108	140	-	3xM8	3xM10	-	3xØ9	6xØ11	-	155	159	25	3	50	120	25	4,2
140 APS	46200054	208	94,9	124,9	159,9	108	140	176	3xM8	3xM10	3xM10	3xØ9	6xØ11	6xØ11	190	194	25	3	60	120	25	5,5
190 APS	46200055	208	94,9	124,9	159,9	108	140	176	3xM8	3xM10	3xM10	3xØ9	6xØ11	6xØ11	190	194	25	3	60	120	25	6,2

MODULE	ID.N.	FINGERS KIT FOR 160 PP-L PL-L GRIPPERS	FINGERS KIT FOR 200 PP-L PL-L GRIPPERS	MANUAL CHUCKS OPTIONALS
100 APS	46200030	46204010	-	SGSF 125-35
140 APS	46200035	46204020	-	SGSF 125-35 / SGSF 160-42
140 APS	46200054	46204030	46204050	SGSF 125-35 / SGSF 160-42 / SGSF 200-55
190 APS	46200055	46204030	46204050	SGSF 125-35 / SGSF 160-42 / SGSF 200-55

5.3 PALLET FOR HG-N CHUCKS prepared for robot loading

SUITABLE
WITH DIN 702/4

Induction-hardened material

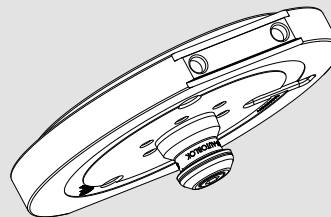
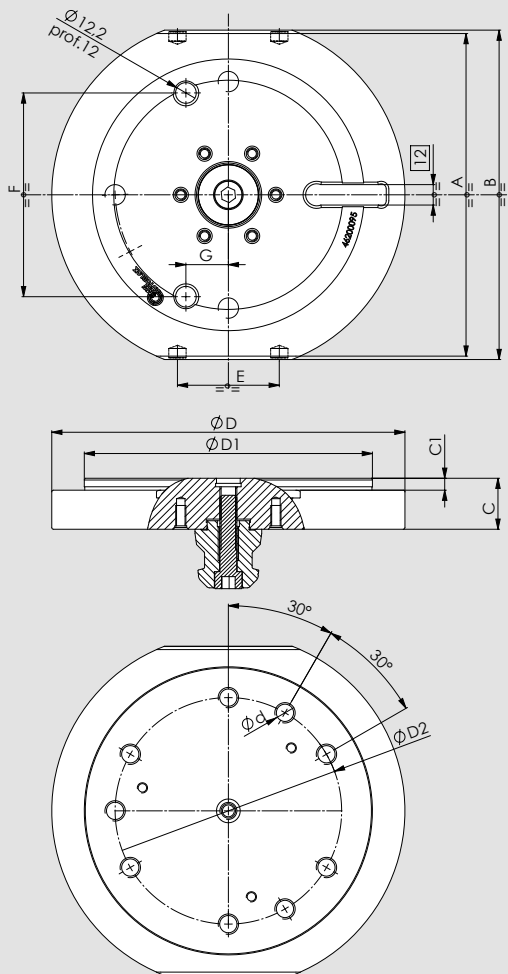

The pallets are prepared for handling with robot using the PP-L and PL-L grippers (refer to the grippers chapters).

MODULE	ID.N. without chuck	PALLET $\varnothing D$	$\varnothing D1$	$\varnothing D2$	$\varnothing d$	A	B	C	C1	E	F	G	FINGERS KIT 160 PP-L PL-L GRIPPERS	FINGERS KIT 200 PP-L PL-L GRIPPERS	WEIGHT
140 APS	46200090	208	139,7	104,8	12xM10	190	194	30	7	60	120	25	46204030	46204050	6,6 Kg
140 APS	46200091	208	169,7	133,4	9xM12	190	194	30	7	60	120	25	46204030	46204050	7 Kg
190 APS	46200092	208	139,7	104,8	12xM10	190	194	30	7	60	120	25	46204030	46204050	7,4 Kg
190 APS	46200093	208	169,7	133,4	9xM12	190	194	30	7	60	120	25	46204030	46204050	7,8 Kg

MANUAL CHUCKS recommended for pallet with manual chucks

Manual chuck HG-N
suitable with flange
DIN702/4
(see side table)

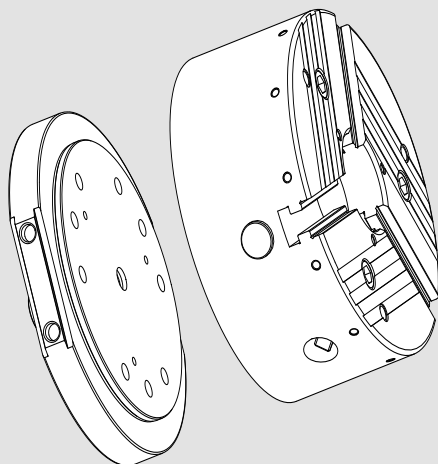

Pallet for chucks HG-N
(see table above)

MANUAL CHUCKS HG-N OPTIONALS

CHUCK MODEL	WITH MODULE	ID.N. FOR PALLET
160/46 HG-N	140 APS	46200090
	190 APS	46200092
210/60 HG-N	140 APS	46200091
	190 APS	46200093

see on the www.smwautoblok.com
the HG-N top jaws

5.4 MANUAL VISES PALLET HOLDER prepared for robot loading

Hardened and tempered material

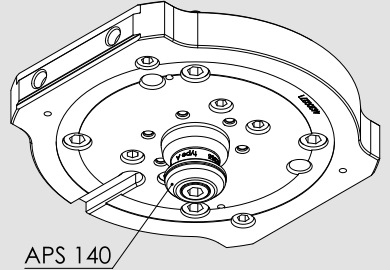
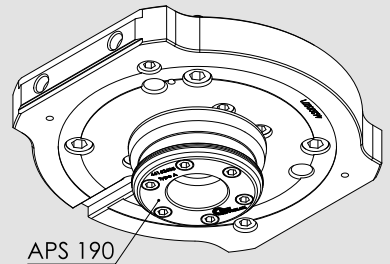

APS 190

APS 140

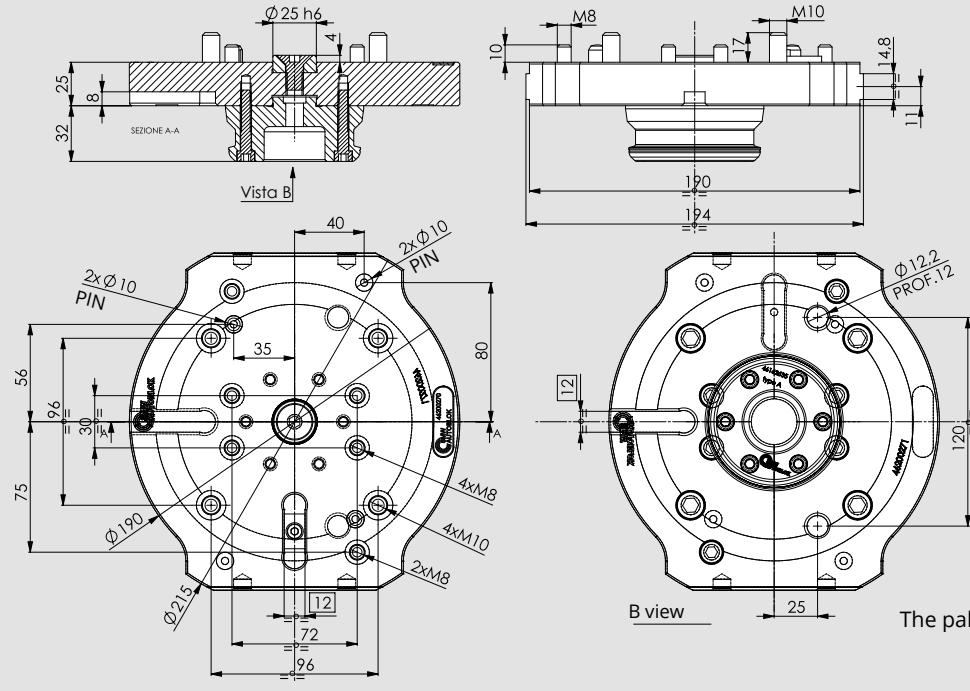

The pallets are prepared for handling with robot using the PP-L and PL-L grippers (refer to the grippers chapters).

ID.N. PALLET WITHOUT VISE	WEIGHT	VISE MODEL (SEE SCHEME BELOW)		
46200275 PALLET HOLDER VISES LOADING ROBOT APS140	6 Kg	100-125 SINTEX	125x220 IMG	125ST5-2G
46200270 PALLET HOLDER VISES LOADING ROBOT APS190	6,7 Kg		125x320 IMG 160x270 IMG	

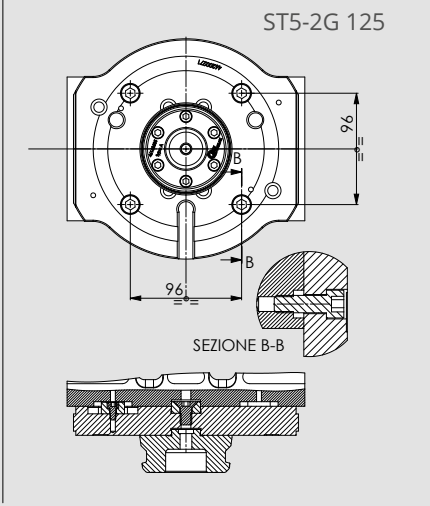
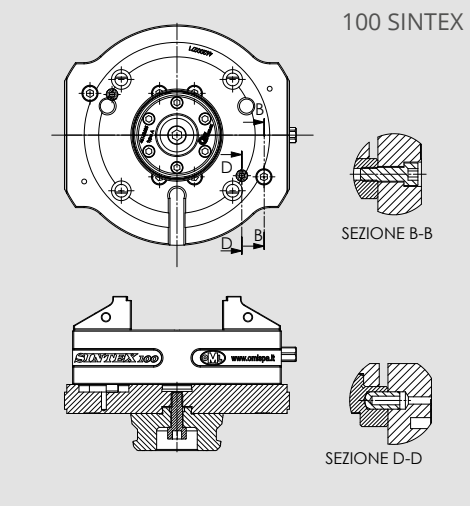
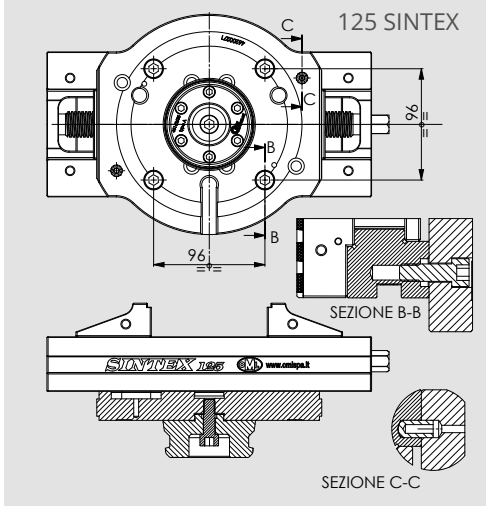
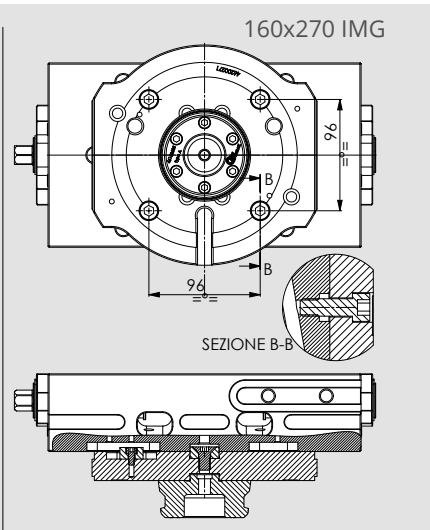
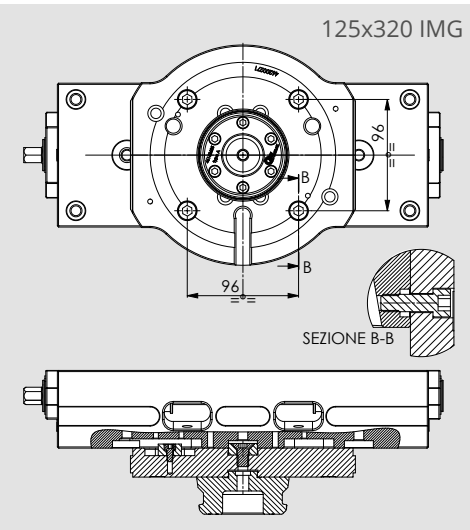
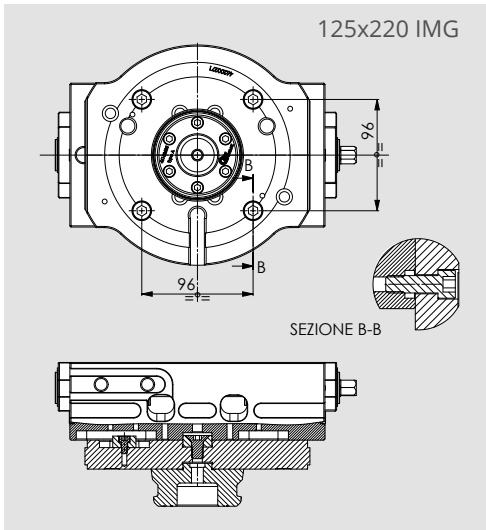

5.5.1 TWO PARTS PALLET prepared for robot loading

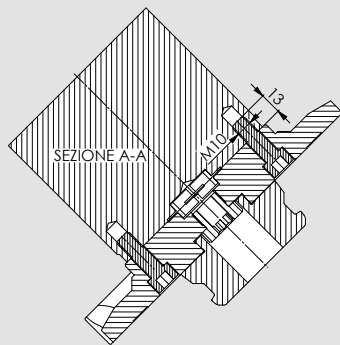
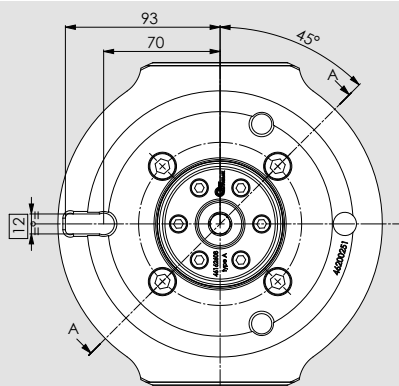

Induction-hardened material

NOT INCLUDED

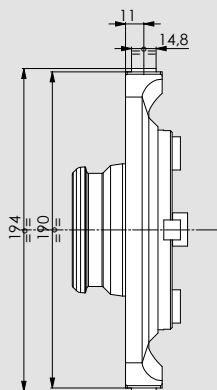
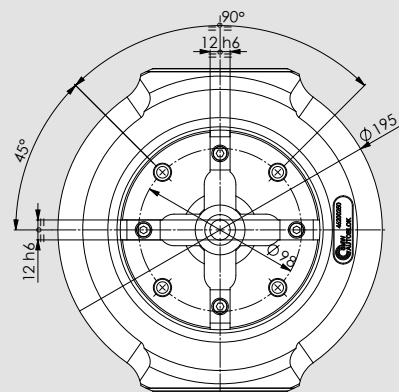
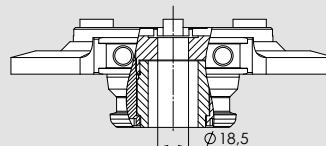
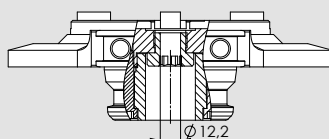
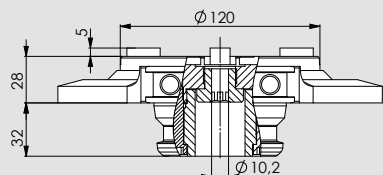
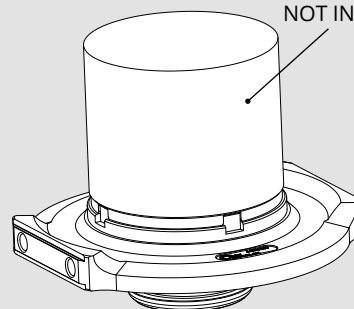

The pallets are prepared for handling with robot using the PP-L and PL-L grippers (refer to the grippers chapters).

ID.N. (SEMI-FINISHED TOOL NOT INCLUDED)

WEIGHT

46200250 - TWO PARTS PALLET WITH CENTRAL SCREW APS190 ROBOT LOADING

5,3 Kg

5.5.2 SEMIFINISHED TOOL for two-pieces pallet

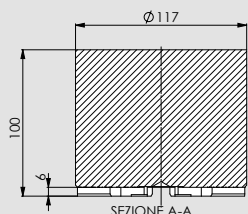
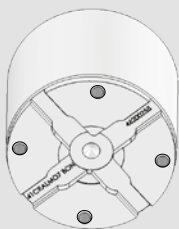
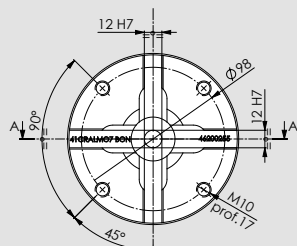

Material: 41CrAlMo7 BON

ID SEMIFISHED TOOL N.

WEIGHT

46200255 - SEMIFINISHED TOOLS- 2PZ WITH CENTRAL SCREW APS 190

8,2 Kg

APPLICATION EXAMPLE

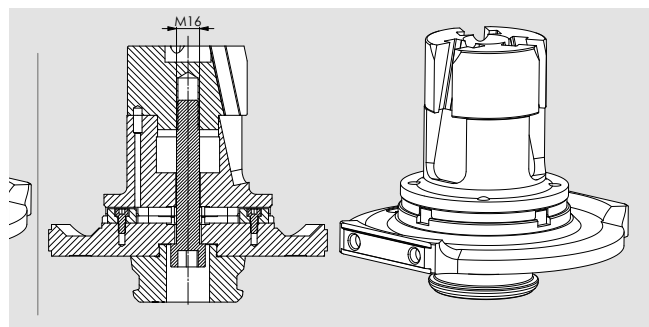
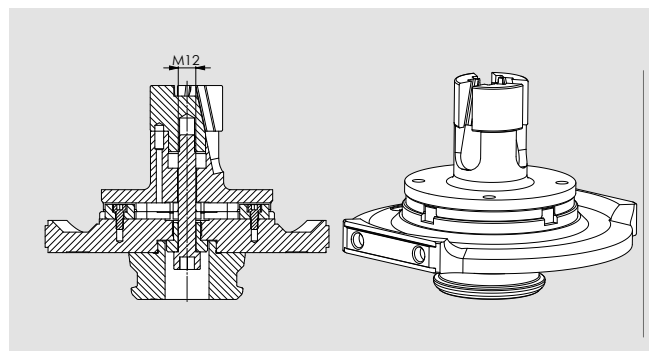

5.6 PALLET-88 prepared for robot loading

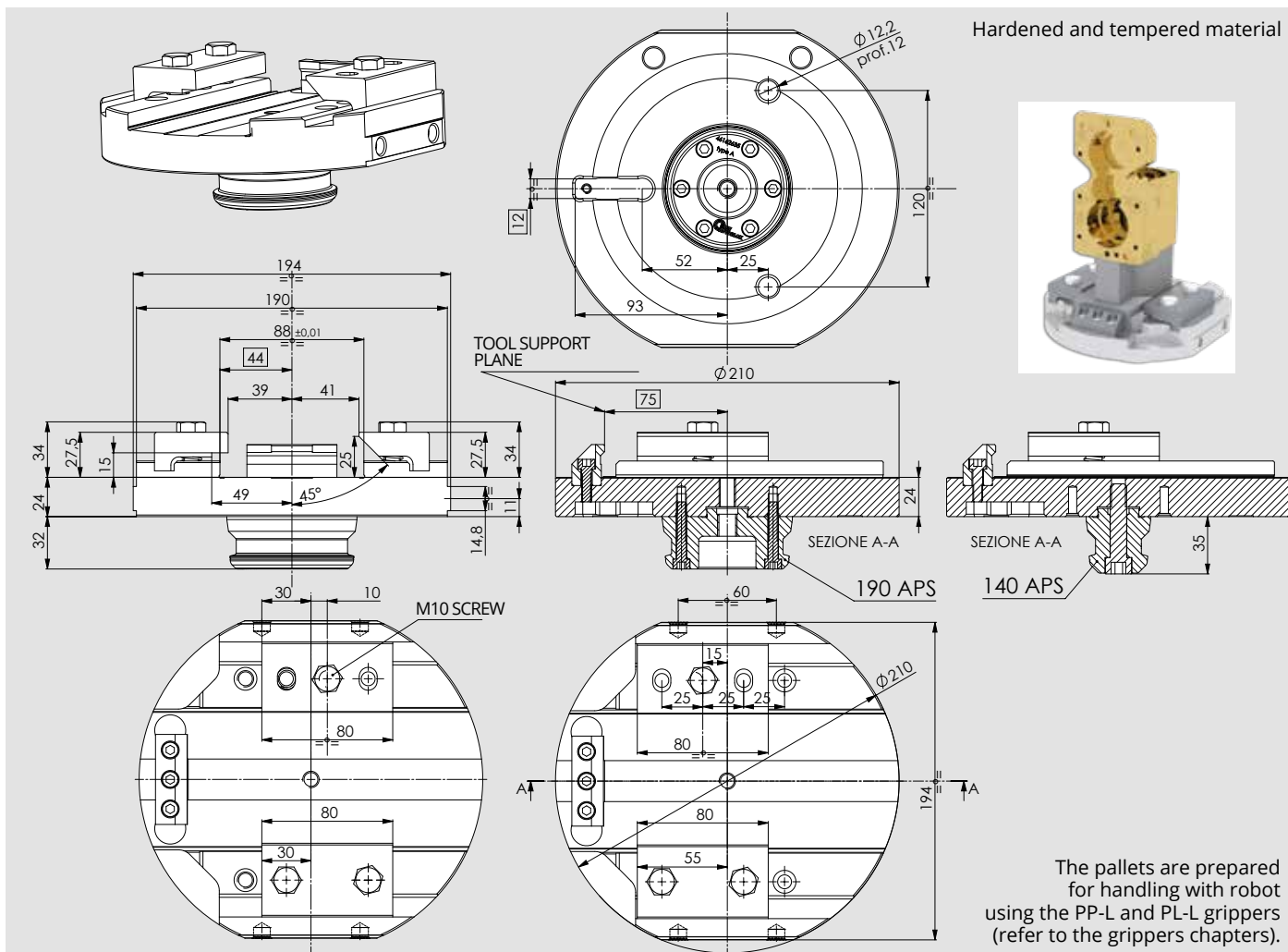

ID.N.	WEIGHT
46200216 - PALLET-88 D210 APS140 LOADING ROBOT	8 Kg
46200210 - PALLET-88 D210 APS190 LOADING ROBOT	8,7 Kg

EXAMPLE OF USE

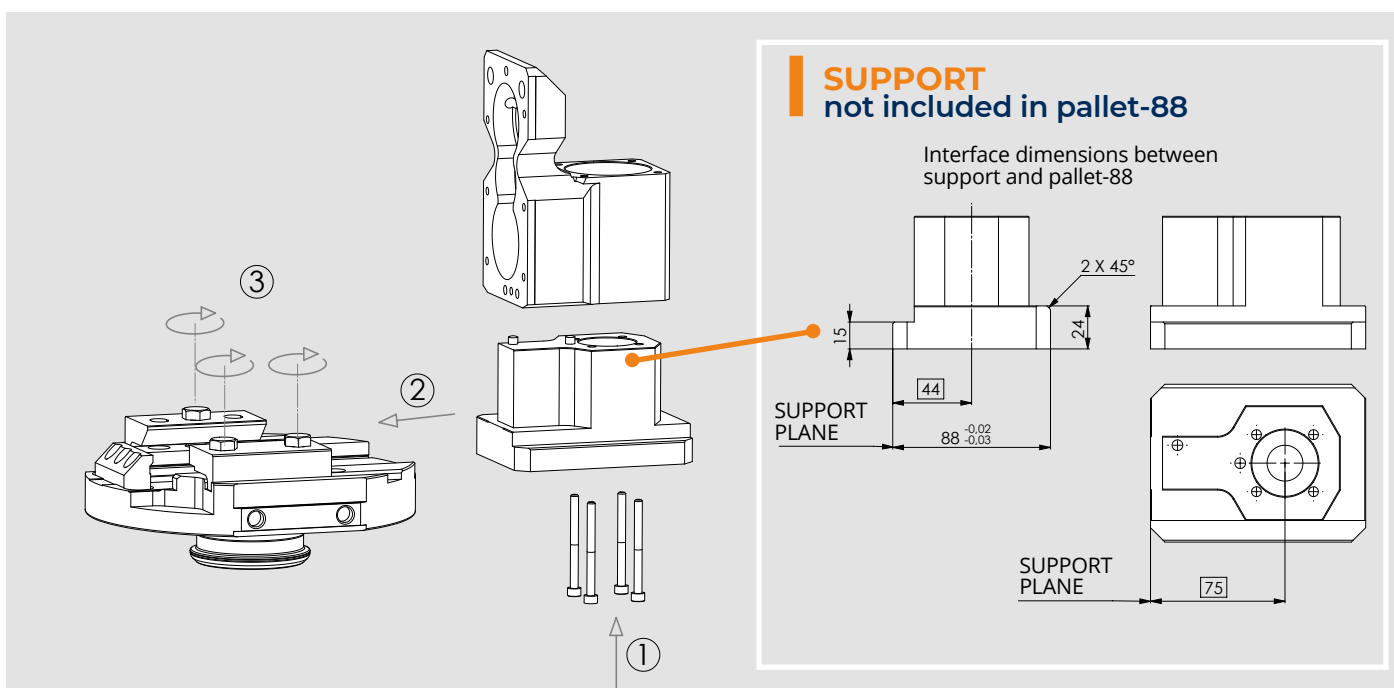

Drawings and data are subject to change by SMW-Autoblok.

5.7 STV PALLET HOLDER WITH ZERO FEEDINGS AND SAB-1 prepared for robot loading

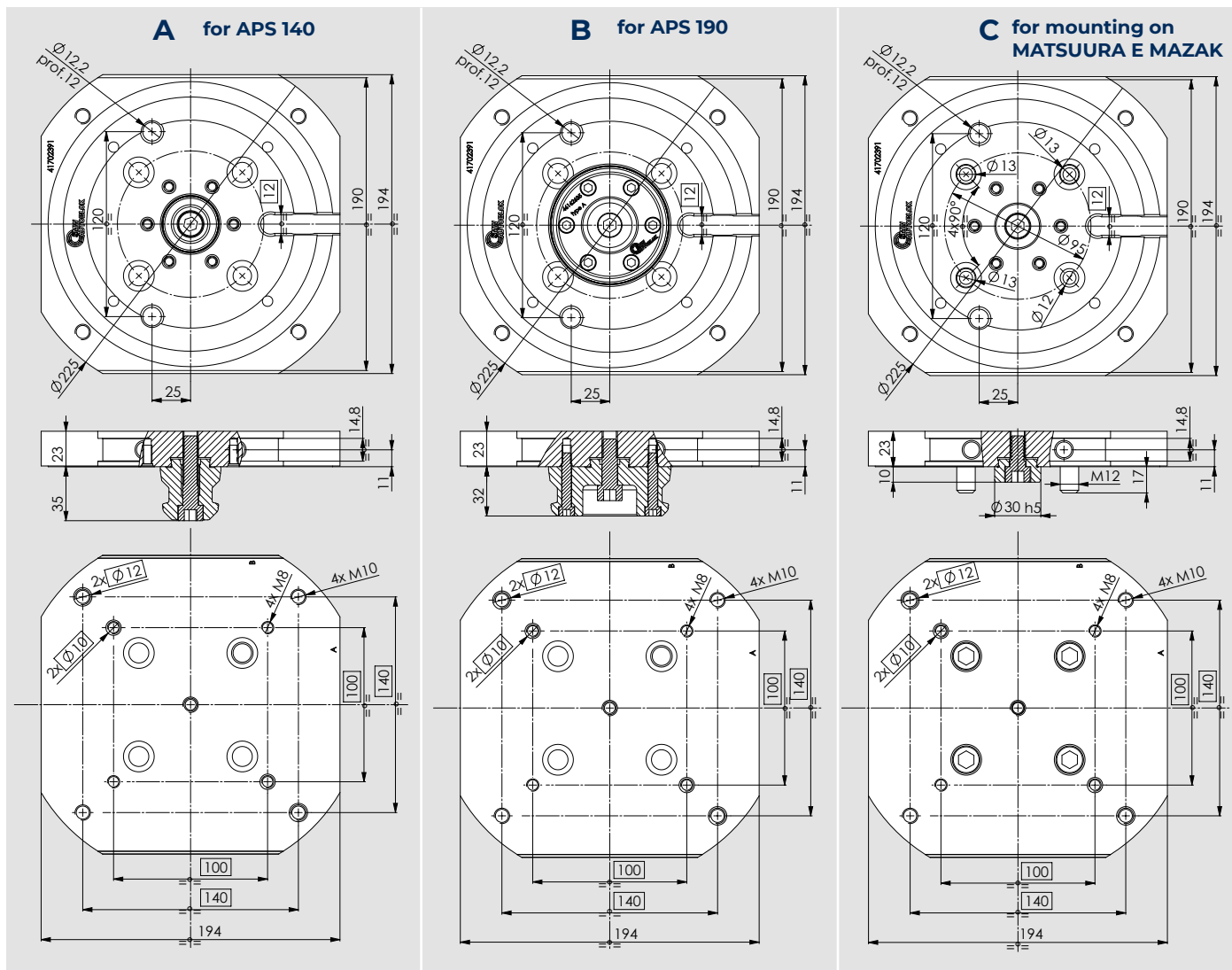

NOT INCLUDED

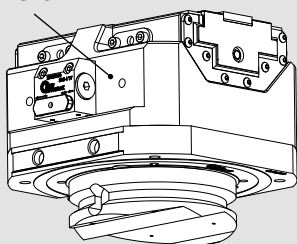

Mounting pallet used on machine tools indicated on the table.

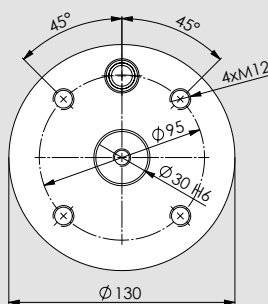

Hardened and tempered material

The pallets are prepared for handling with robot using the PP-L and PL-L grippers (refer to the grippers chapters).

On these pallets the TWIN VISE can be mounted only if the SAB-1 valve is mounted.

ID.N. PALLET (VISE NOT INCLUDED)	WEIGHT	TWIN VISE MODEL +SAB-1 STD USABLE (OPTIONAL)	MODULE APS	MACHINE TOOLS PALLET
A 46200280 GRP PALLET Q194 STV HOLDER VISE ON APS 140	6,2 Kg		APS 140	-
B 46200281 GRP PALLET Q194 STV HOLDER VISE ON APS 190	6,8 Kg	125 STV-2 180 STV-2 180 STV-3	APS 190	-
C 46200282 GRP PALLET Q194 STV HOLDER VISE ON PALLET Ø 130	6,1 Kg		-	MATSUURA MAM-72 MATSUURA MX 330 MAZAK 300 HSK 100

5.8A 180 STV PALLET HOLDER WITH 2-4 FEEDINGS prepared for robot loading

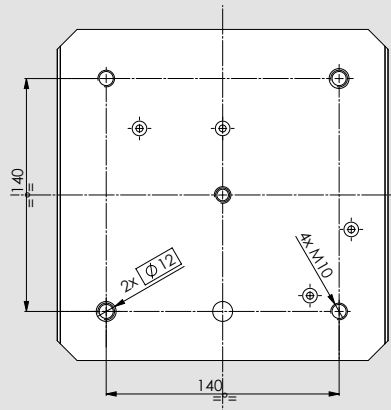
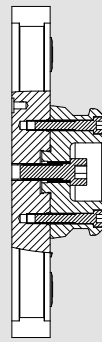
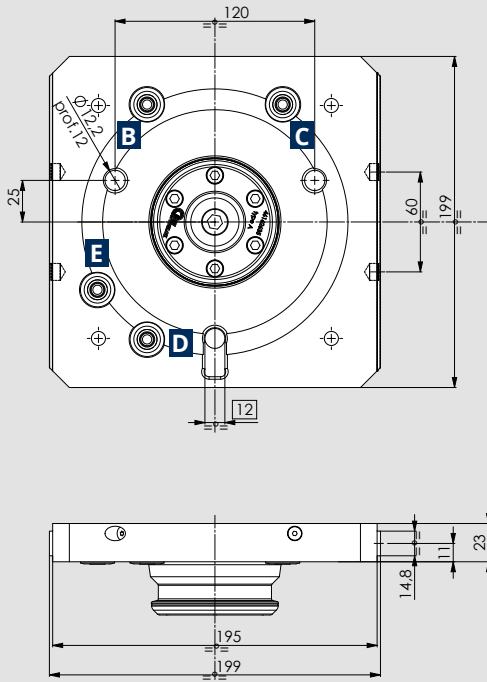

Hardened
and tempered
material

The pallets are
prepared for handling
with robot
using the PP-L and
PL-L grippers (refer
to the grippers
chapters).

NOT INCLUDED

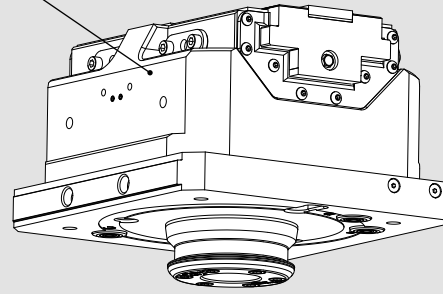

- B** TWIN VISE open
- C** TWIN VISE closed
- D** TWIN VISE stroke control valve
- E** Air sensing Twin vise

ID.N. PALLET (VISE AND COUPLERS NOT INCLUDED)

FEEDINGS
TO USE

WEIGHT

46200104 PALLET HOLDER 180STV 2-3J APS190 ROBOT LOADING PREPARED FOR 4 FEMALE COUPLERS

B-C-D-E

7,7 Kg

71718105 FEMALE COUPLER

-

0,030 kg

5.8B 225 STV PALLET HOLDER WITH 2-4 FEEDINGS prepared for robot loading

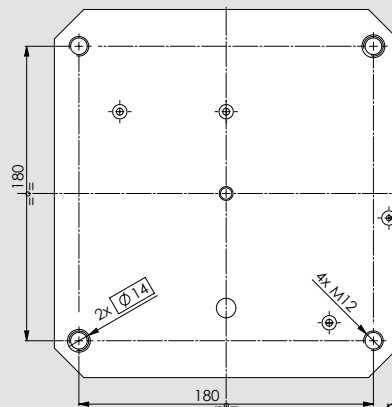
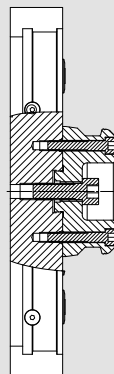
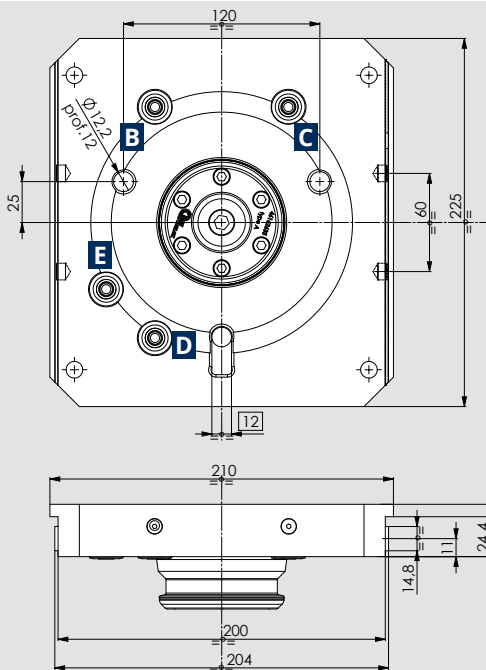

Hardened
and tempered
material

The pallets are
prepared for handling
with robot
using the PP-L and
PL-L grippers (refer
to the grippers
chapters).

NOT INCLUDED

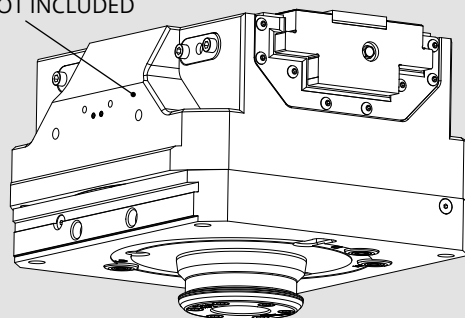

- B** TWIN VISE open
- C** TWIN VISE closed
- D** Stroke control valve TWIN VISE
- E** Air sensing Twin vise

ID.N. PALLET (VISE AND COUPLERS NOT INCLUDED)

FEEDINGS
TO USE

WEIGHT

46200109 PALLET HOLDER 225STV 2-3J APS190 ROBOT LOADING PREPARED FOR 4 FEMALE COUPLERS

B-C-D-E

12 Kg

71718105 FEMALE COUPLER

-

0,030 kg

5 AXIS SOLUTION WITH N.4 PNEUMATIC FEEDINGS: all feedings for APS control

Upper plate manual change or by robot



46200055

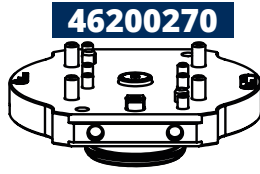

46200270

125 STV-2N + SAB1 STD **77904812**

125 STV-2L + SAB1 STD **77904912**

180 STV-2N + SAB1 STD **77904818**

180 STV-2L + SAB1 STD **77904918**

180 STV-3N + SAB1 STD **77905018**

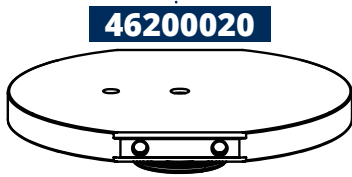

46200020



46200092

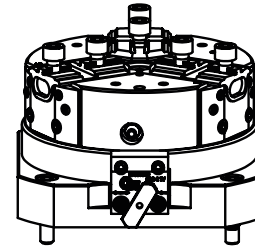

46200281

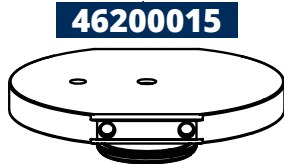

46200015



46200093

REFER TO THE GRIPPERS
CHAPTERS

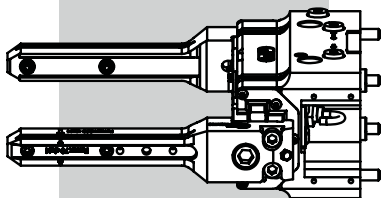

Antirotation key

46162333

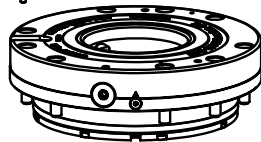

APS190 E PREMIUM SC

46165640

PORT1 = APS opening (A)
PORT2 = APS air sensing (C)
PORT3 = APS turbo function (T)
PORT4 = APS stroke control SC (E)

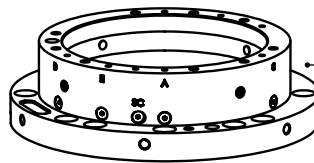

Extension module for APS

46203000



T-Nuts set

(only if required)



Customized distributor

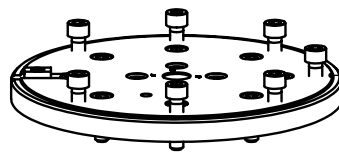

Adapting flange

(only if required)

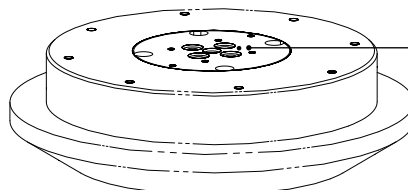

N.4 FEEDINGS

PORT1 = APS opening (A)
PORT2 = APS air sensing (C)
PORT3 = APS turbo function (T)
PORT4 = APS stroke control SC (E)

5 AXIS SOLUTION WITH N.4 PNEUMATIC FEEDINGS:
n.2 on APS + n.2 on the pallet

Upper plate manual change or by robot
Workpiece manual loading or by robot



77904618

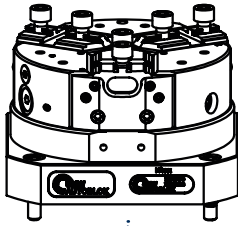

180STV-2N **77904318**
180STV-2L **77904418**

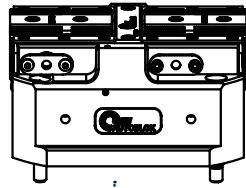

225STV-2N **77904322**
225STV-2L **77904422**

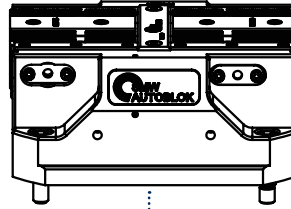

225STV-3N **77904622**
225STV-3L **77904722**

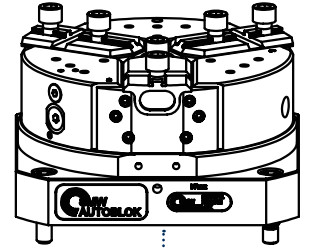

46200104

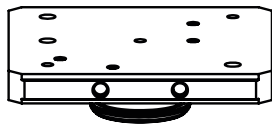

PORT3 = STV vise opening (B)
PORT4 = STV vise closing (C)

46200109

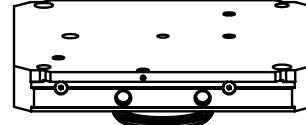

REFER TO THE GRIPPERS
CHAPTERS

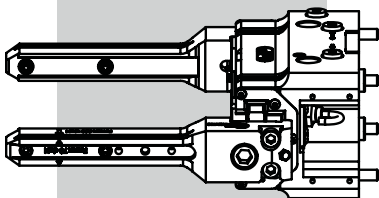

* SEE TWIN VISES
CATALOGUE

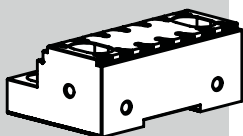

Antirotation key

46162333

Male coupler

71718106

APS190 E PREMIUM SC 6S

46162650

PORT1 = APS opening (A)
PORT2 = APS air sensing (T)



Extension module for APS

46203000

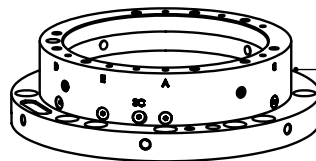

T-Nuts set
(only if required)



Customized distributor



Adapting flange
(only if required)

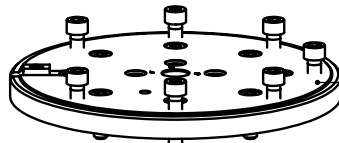

N.4 FEEDINGS

PORT1 = APS opening (A)
PORT2 = APS air sensing (T)
PORT3 = STV vise opening (B)
PORT4 = STV vise closing (C)

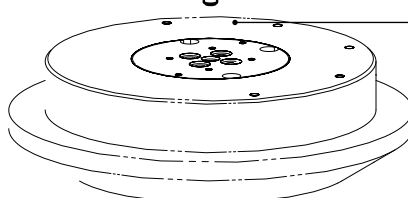

5 AXIS SOLUTION WITH N.6 PNEUMATIC FEEDINGS: n.3 on APS + n.3 on the pallet

Upper plate manual change or by robot
Workpiece manual loading or by robot

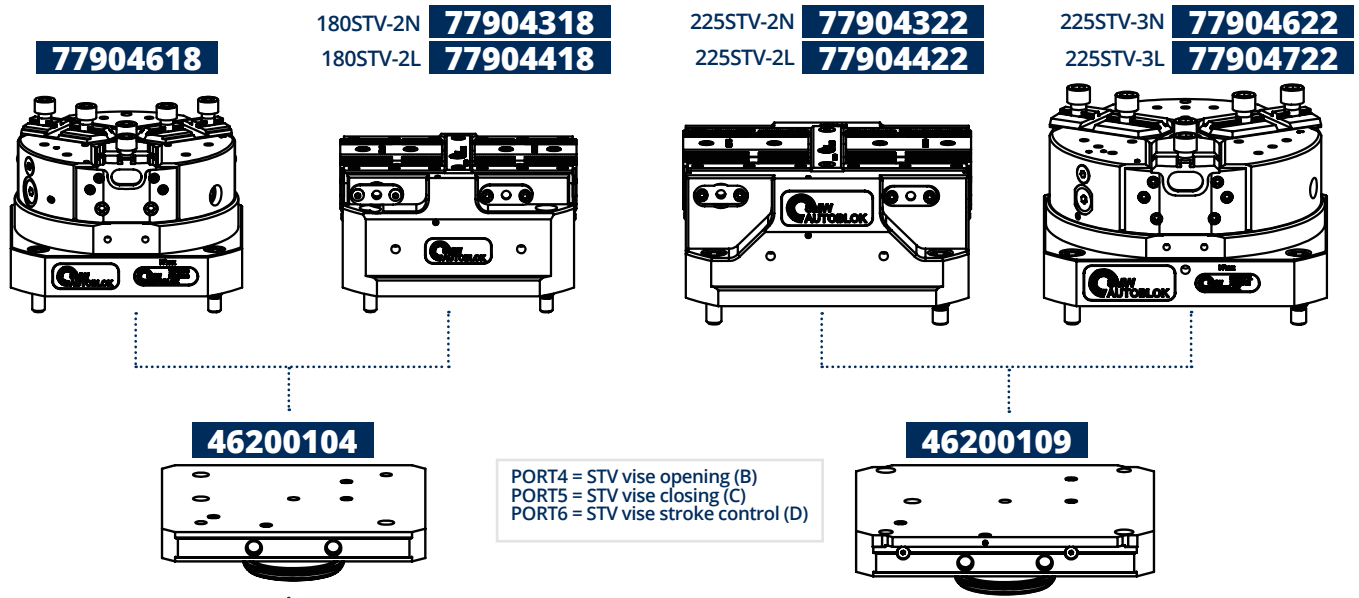
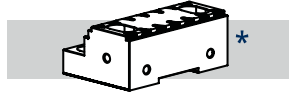

REFER TO THE GRIPPERS
CHAPTERS

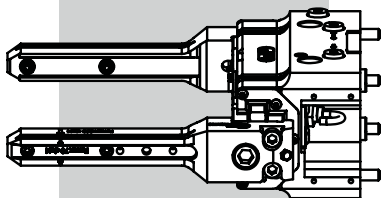

* SEE TWIN VISES
CATALOGUE

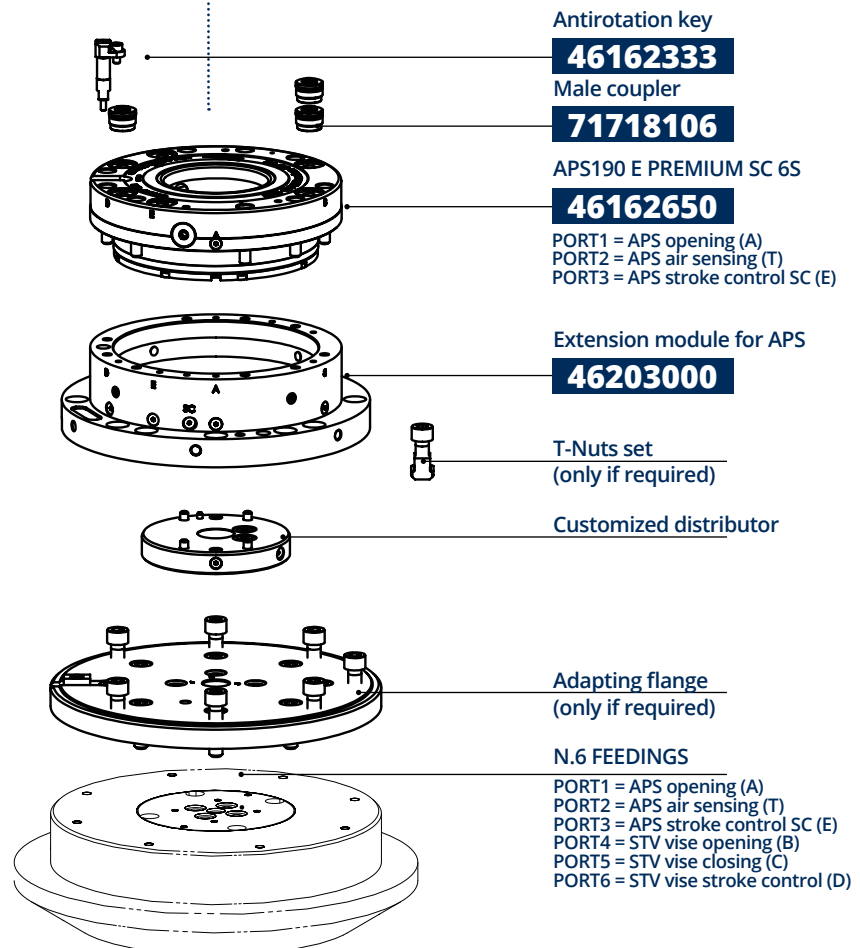
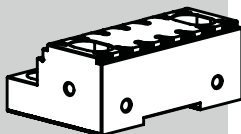

MULTIPLE CLAMPING PALLET WITH 2 APS 140 semifinished pallet

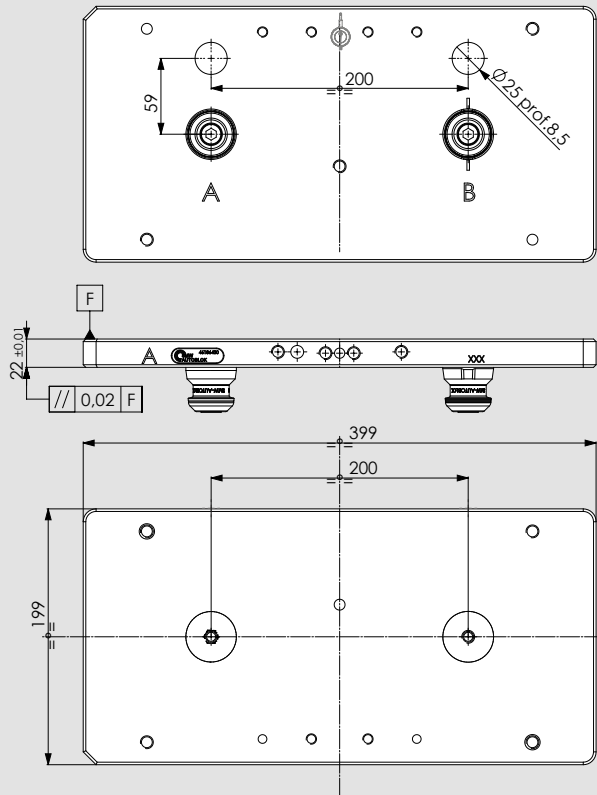

BASIC VERSION

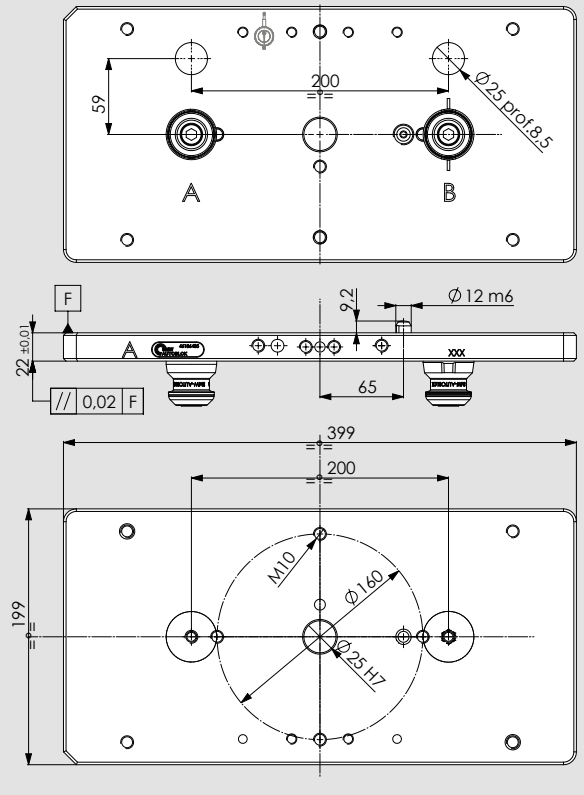

PREMIUM VERSION

The pallets are prepared for loading with robot using the PL-N and PP-N 200 grippers (refer to the grippers chapter).

ID.N. COMPLETE PALLET	WEIGHT
46186435 CLAMPING PALLET PREMIUM SP22 2APS-140	14 Kg
46186430 CLAMPING PALLET BASIC SP22 2APS-140	14 Kg

APPLICATION EXAMPLE with PREMIUM CLAMPING PALLET 2 APS 140

- 460113 MODULE HEIGHT EXTENSION APS 140 H80
- 460114 MODULE HEIGHT EXTENSION APS 140 H120
- 460115 MODULE HEIGHT EXTENSION APS 140 H180

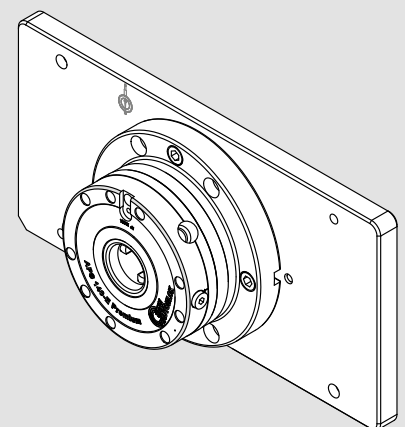
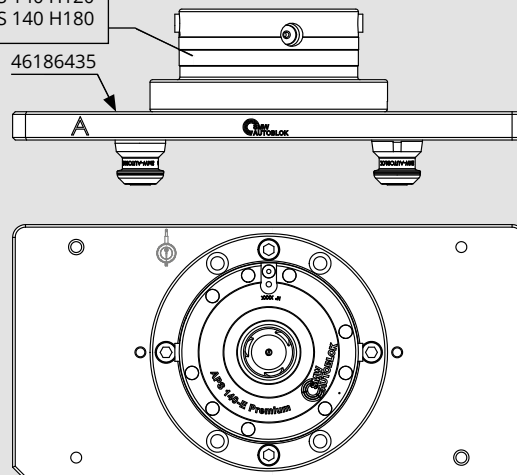

Drawings and data are subject to change by SMW-Autoblok.

MULTIPLE CLAMPING PALLET WITH 4 APS 140 semifinished pallet

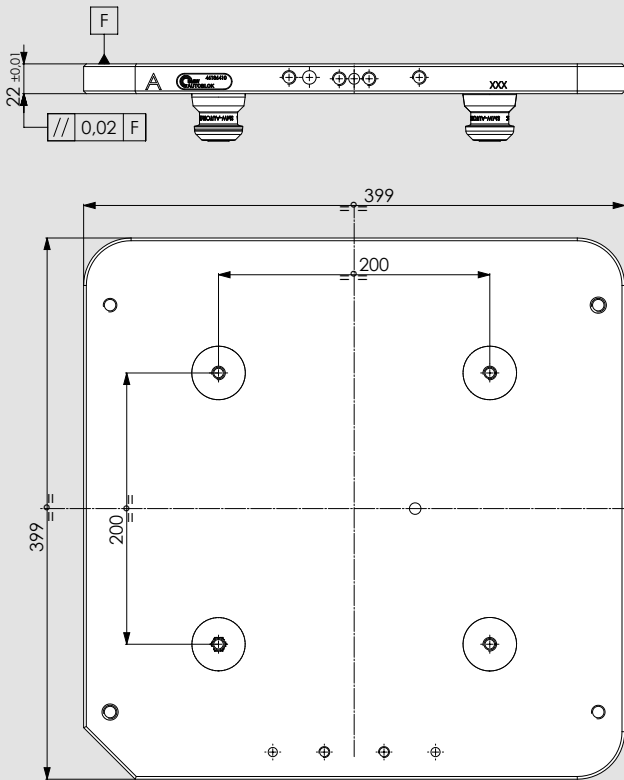

BASIC VERSION

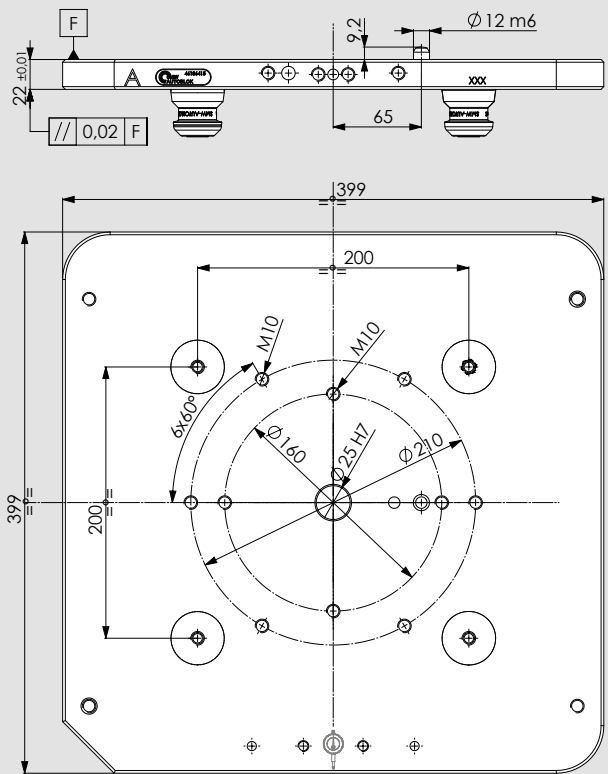

PREMIUM VERSION

The pallets are prepared for loading with robot using the PL-N and PP-N 200 grippers (refer to the grippers chapter).

ID.N.COMPOSITE PALLET	WEIGHT
46186415 CLAMPING PALLET PREMIUM SP22 4APS-140	28 Kg
46186410 CLAMPING PALLET BASIC SP22 4APS-140	28 Kg

APPLICATION EXAMPLE with PREMIUM CLAMPING PALLET 4 APS 140

- 460113 MODULE HEIGHT EXTENSION APS 140 H80
- 460114 MODULE HEIGHT EXTENSION APS 140 H120
- 460115 MODULE HEIGHT EXTENSION APS 140 H180
- 460111 MODULE HEIGHT EXTENSION APS 190 H100
- 41702305 MOD.HEIGHT EXTENSION APS 190+SAB1 STD H100

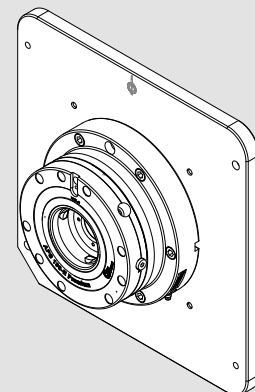
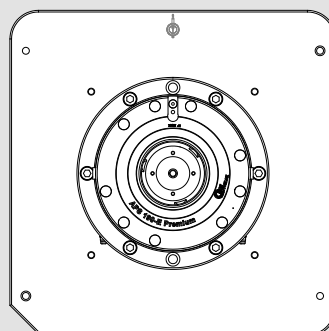
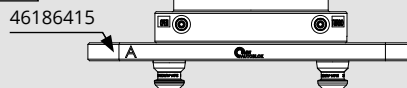

MULTIPLE CLAMPING PALLET WITH 6 APS 140 semifinished pallet

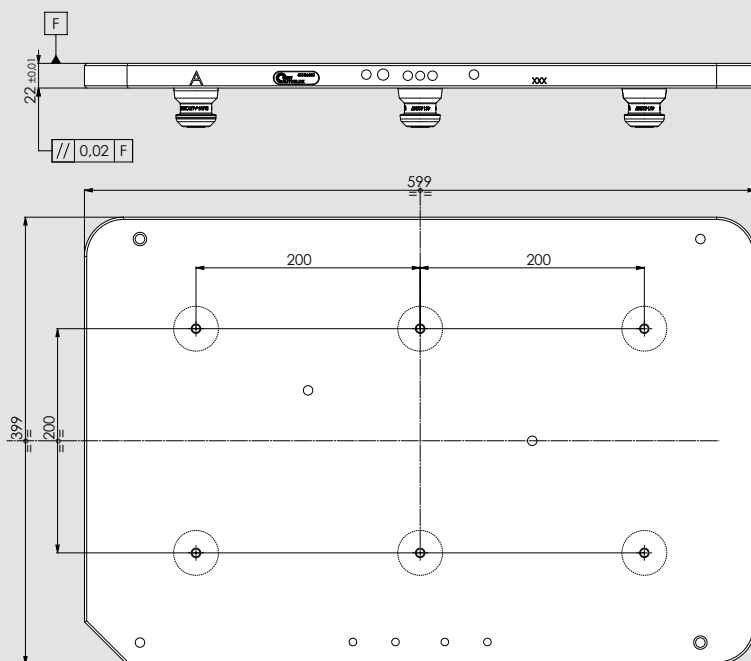

ID.N. COMPLETE PALLET

46186680 CLAMPING PALLET BASIC SP22 6APS-140

WEIGHT

42 Kg

APPLICATION EXAMPLE with BASIC CLAMPING PALLET 6 APS 140

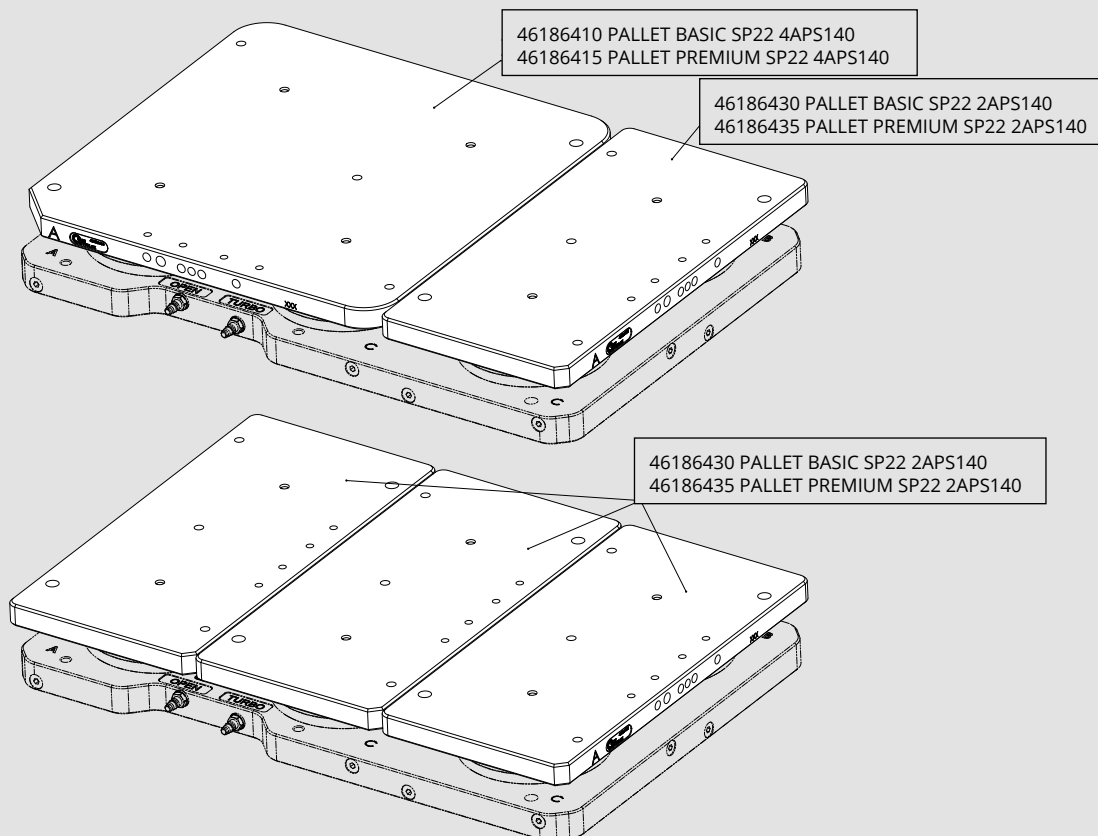

Q400 CLAMPING PALLET CHUCK SGSF

pallet prepared for mounting SGSF chucks

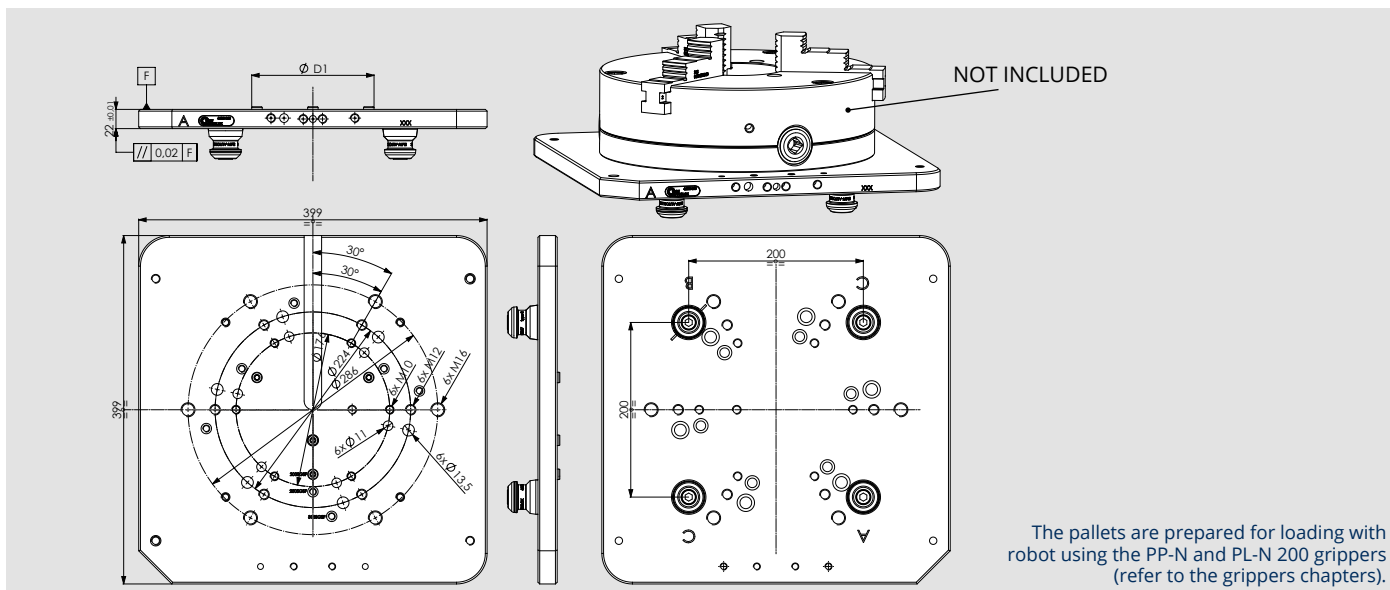

The pallets are prepared for loading with robot using the PP-N and PL-N 200 grippers (refer to the grippers chapters).

PALLET ID.N. (CHUCK NOT INCLUDED)	WEIGHT	MANUAL CHUCKS SGSF (OPTIONAL)	
46201020 CLAMPING PALLET Q400 PREPARED FOR CHUCKS 200-250-315 SGSF HANDLING ROBOT	28 Kg	$\varnothing D1$	CHUCK MODEL
		159,9	200 SGSF
		199,9	250 SGSF
		259,9	315 SGSF

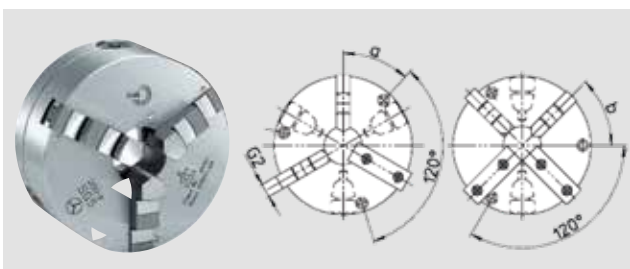

CHUCK TYPE SGS-SGSF	200-55	250-76	315-103
Front thread 3+3	33031220	33031225	33031231
Front thread 4+4	33033220	33033225	33033231
 Set-3 GRC	03652030	03652530	03653130
 Set-4 GRC	03652040	03652540	03653140
 Set-3 Soft jaws	03602030	03602530	03603130
 Set-4 Soft jaws	03602040	03602540	03603140

Q400 CLAMPING PALLET CHUCKS HG-N

pallet prepared for mounting HG-N chucks

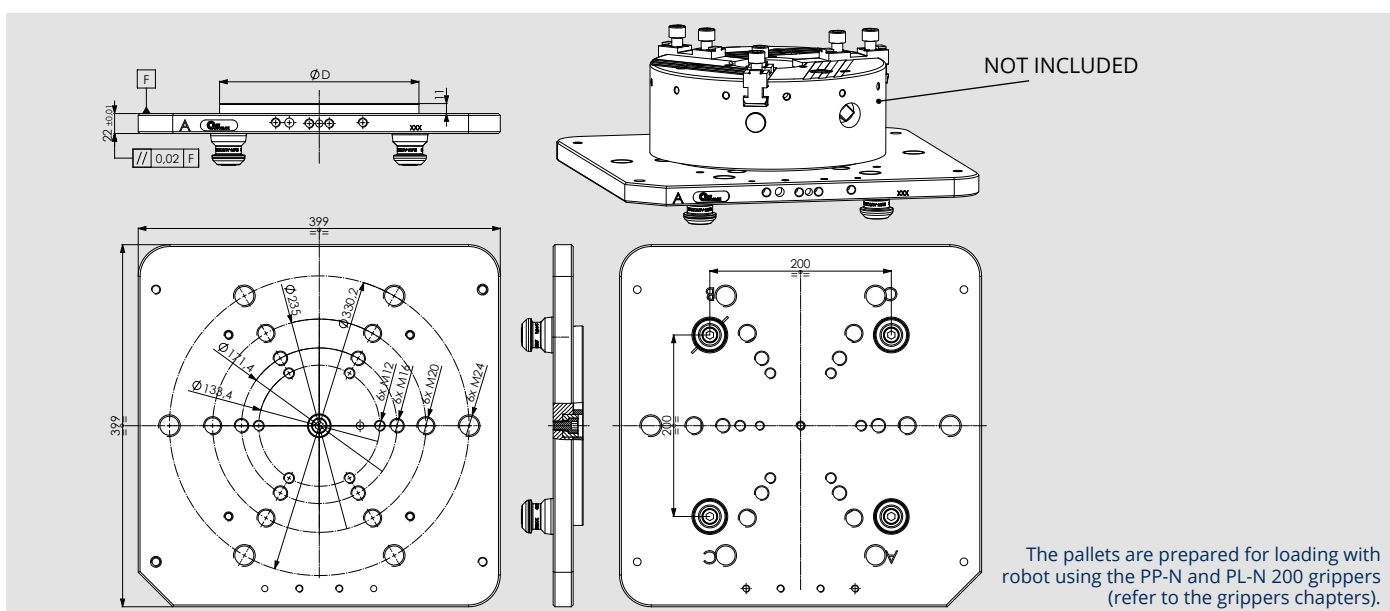

The pallets are prepared for loading with robot using the PP-N and PL-N 200 grippers (refer to the grippers chapters).

PALLET ID.N. (CHUCK NOT INCLUDED)	$\varnothing D$	WEIGHT
46201012 GRP PALLET Q400 + MOUNTING D220 AUTC 260HG LOADING ROBOT	219,7	30 Kg
46201013 GRP PALLET Q400 + MOUNTING D300 AUTC 315HG LOADING ROBOT	299,7	32 Kg
46201014 GRP PALLET Q400 + MOUNTING D380 AUTC 400-500HG MANUAL LOADING	379,7	36 Kg

4 APS 140 CLAMPING PALLET STV SAB-1 HOLDER pallet without feedings for vises STV+SAB-1 STANDARD

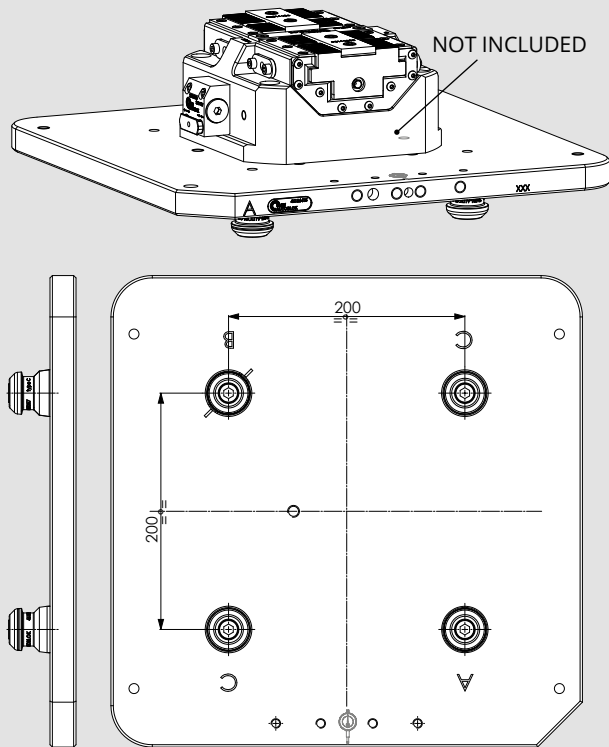
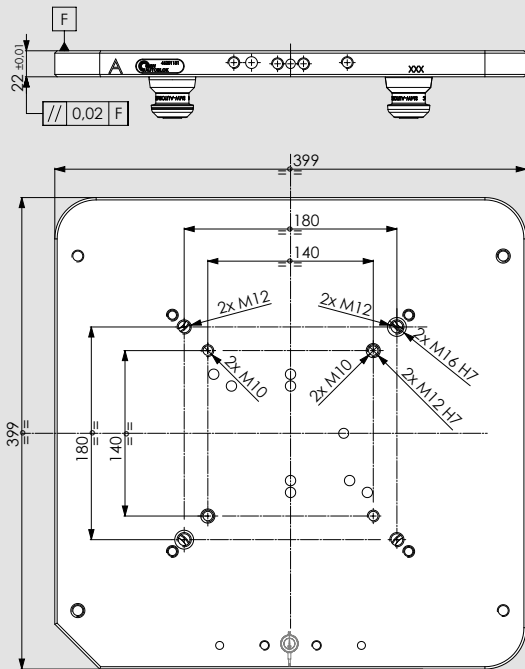

The pallets are prepared for loading with robot using the PP-N and PL-N 200 grippers (refer to the grippers chapters).

PALLET ID.N. (VISE NOT INCLUDED)

WEIGHT

46201131 CLAMPING PALLET Q400 PREPARED FOR 180/225 STV WITH SAB-1 STD ROBOT LOADING

28 Kg



STV MODELS AVAILABLE ON THIS PALLET:

MODEL	ID.N.
180 STV-2N + SAB-1 STD	77904818*
180 STV-2L + SAB-1 STD	77904918*
180 STV-3N + SAB-1 STD	77905018*
225 STV-2N + SAB-1 STD	77904822**
225 STV-2L + SAB-1 STD	77904922**
225 STV-3N + SAB-1 STD	77905022**
225 STV-3L + SAB-1 STD	77905122**

*attention! this STV vise must be mounted in standard solution1 (see product manual)
**attention! this STV vise must be mounted in standard solution2 (see product manual)



4 APS 140 CLAMPING PALLET STV HOLDER pallet with n.4 feedings

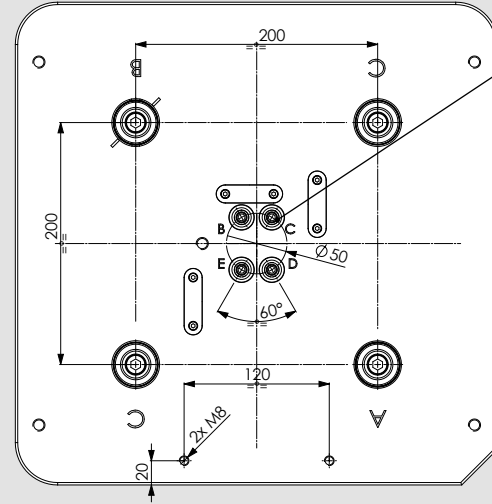
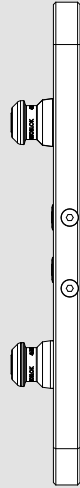
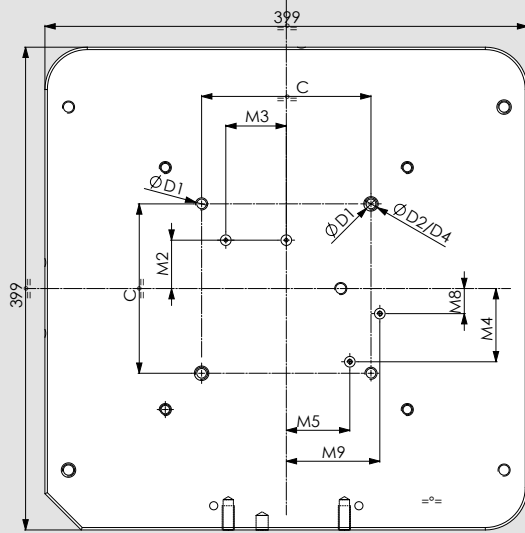
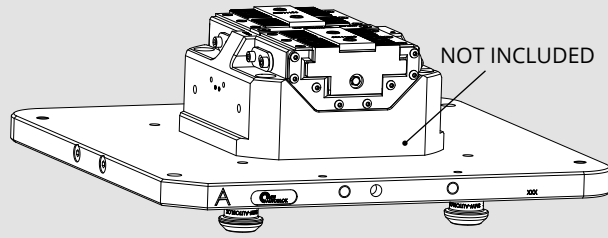
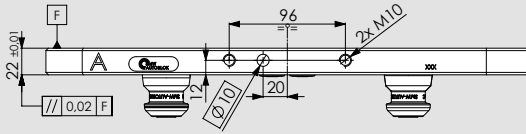

The pallets are prepared for loading with robot using the PP-N e PL-N 200 grippers (refer to the grippers chapters).

ID N. PALLET (NOT INCLUDED VISES AND COUPLERS)	WEIGHT
46201115 CLAMPING PALLET Q400 180 STV 2/3J ROBOT LOADING PREPARED FOR 4 FEMALE COUPLERS	28 Kg
46201105 CLAMPING PALLET Q400 225 STV 2/3J ROBOT LOADING PREPARED FOR 4 FEMALE COUPLERS	28 Kg
71718105 FEMALE COUPLER	0,030 Kg

PALLET	C	D1	D2 H7	D4 H7	M2	M3	M4	M5	M8	M9	STV MODELS AVAILABLE ON THIS PALLET:	
											MODEL	ID.N.
46201115	140	M10	12	/	40	50	60,5	52,5	20,7	77,3	180 STV-2N	77904318*
											180 STV-2L	77904418*
											180 STV-3N	77904618*
46201105	180	M12	/	16	50	65	79	63	15	99,9	225 STV-2N	77904322**
											225 STV-2L	77904422**
											225 STV-3N	77904622**
											225 STV-3L	77904722**

*attention! this STV vise must be mounted in standard solution 1 (see product manual)
 **attention! this STV vise must be mounted in standard solution 2 (see product manual)



The feedings **B C D E** are transferred on the pallet between pneumatic/hydraulic couplers

- B** TWIN VISE open
- C** TWIN VISE closed
- D** Stroke control valve TWIN VISE
- E** Air sensing TWIN VISE

4 APS 140 MULTIPLE CLAMPING PALLET HOLDER N.4 125 STV pallet with 4 FEEDINGS

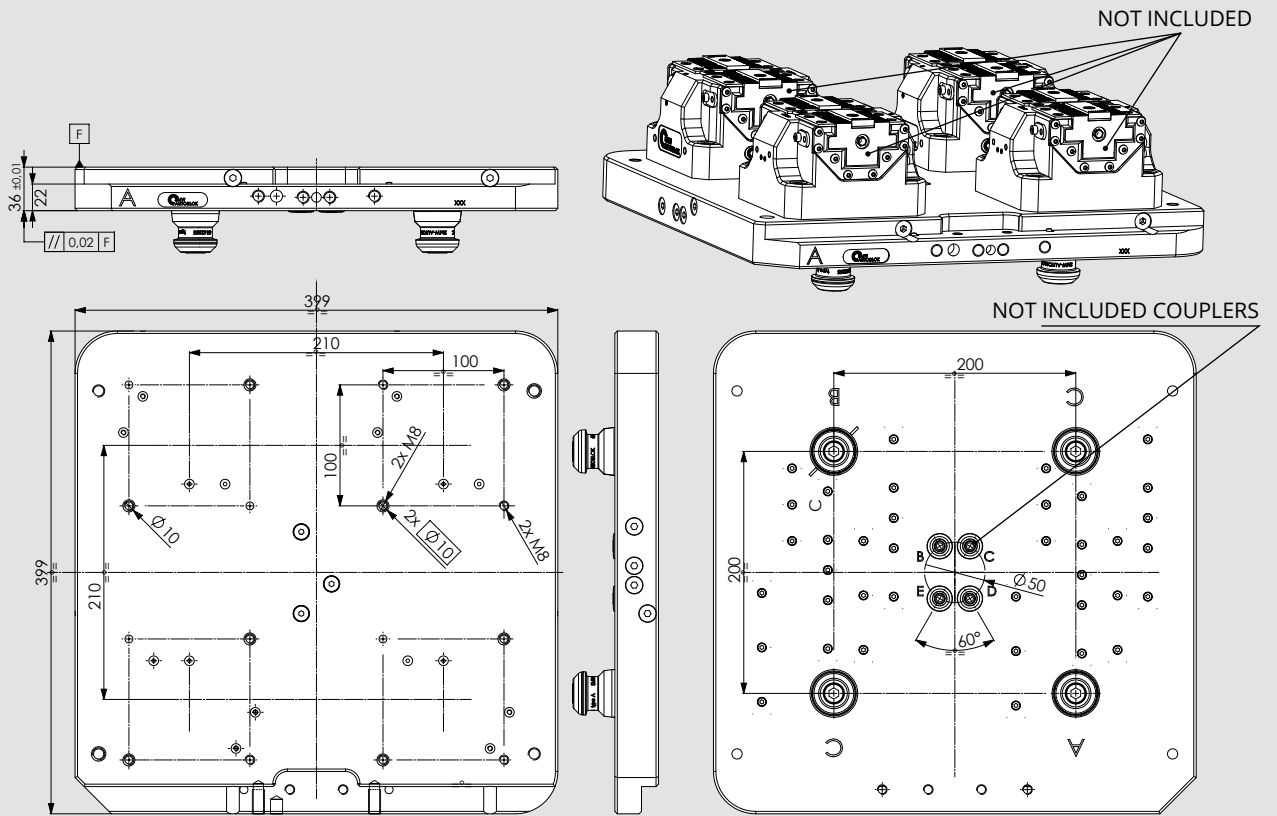

The pallets are prepared for loading with robot using the PP-N and PL-N 200 grippers (refer to the grippers chapters).

ID.N. PALLET (NOT INCLUDED VISES AND COUPLERS)	WEIGHT
46201125 CLAMPING PALLET Q400 125 STV ROBOT LOADING PREPARED FOR 4 FEMALE COUPLERS	44 Kg
71718105 FEMALE COUPLERS	0,030 Kg



STV MODEL AVAILABLE ON THIS PALLET:	
MODEL	ID.N.
125 STV-2N	77904312
125 STV-2L	77904412

The feedings **B C D E** are transferred on the pallet between pneumatic/hydraulic couplers

- B** TWIN VISE open
- C** TWIN VISE closed
- D** Stroke control valve TWIN VISE
- E** Air sensing TWIN VISE

5 AXIS MACHINE SOLUTION WITH N.2 PNEUMATIC FEEDINGS: all feeding on the APS control

Upper plate manual change or by robot

46201012
46201013
46201014

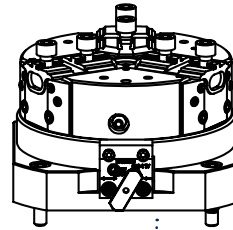
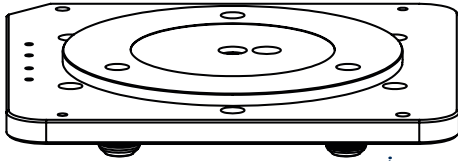

180STV-2N+ SAB1* **77904818**
180STV-2L+ SAB1* **77904918**
180STV-3N+ SAB1* **77905018**
225STV-2N+ SAB1* **77904822**
225STV-2L+ SAB1* **77904922**
225STV-3N+ SAB1* **77905022**
225STV-3L+ SAB1* **77905122**

NOTE: SAB1*=SAB-1 STANDARD



46201020



46201131

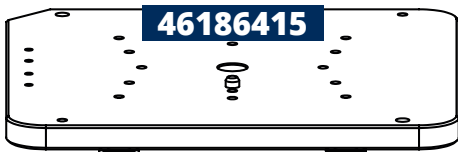

46186415

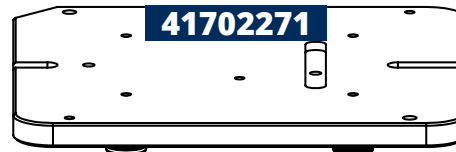

41702271

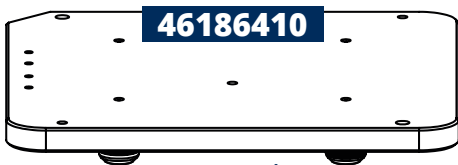

46186410

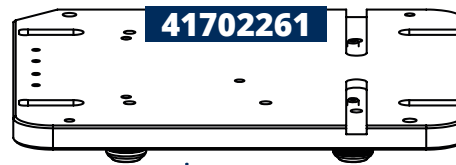

41702261

REFER TO THE GRIPPERS CHAPTERS

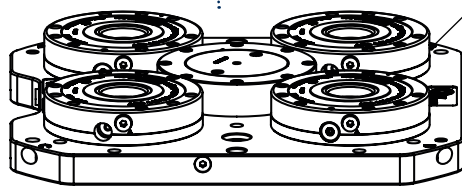
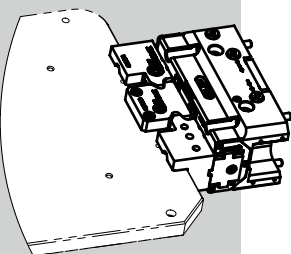

Pallet with 4APS140

46202000

PORT1 = APS opening (A)
PORT2 = APS air sensing and
APS miniturbo function (T)

T-Nuts set
(only if required)

Customized distributor

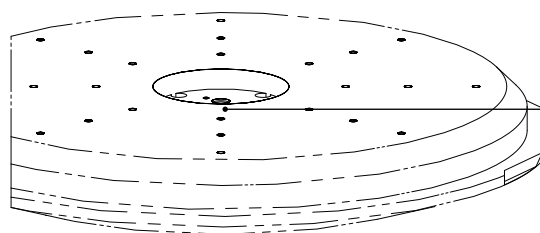

N.2 FEEDINGS

PORT1 = APS opening (A)
PORT2 = APS air sensing and
APS miniturbo function (T)

5 AXIS MACHINE SOLUTION WITH N.4 PNEUMATIC FEEDINGS:
n.2 for APS control + n.2 for upper plate

Upper plate manual change or by robot
Workpiece manual loading or by robot

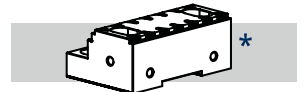
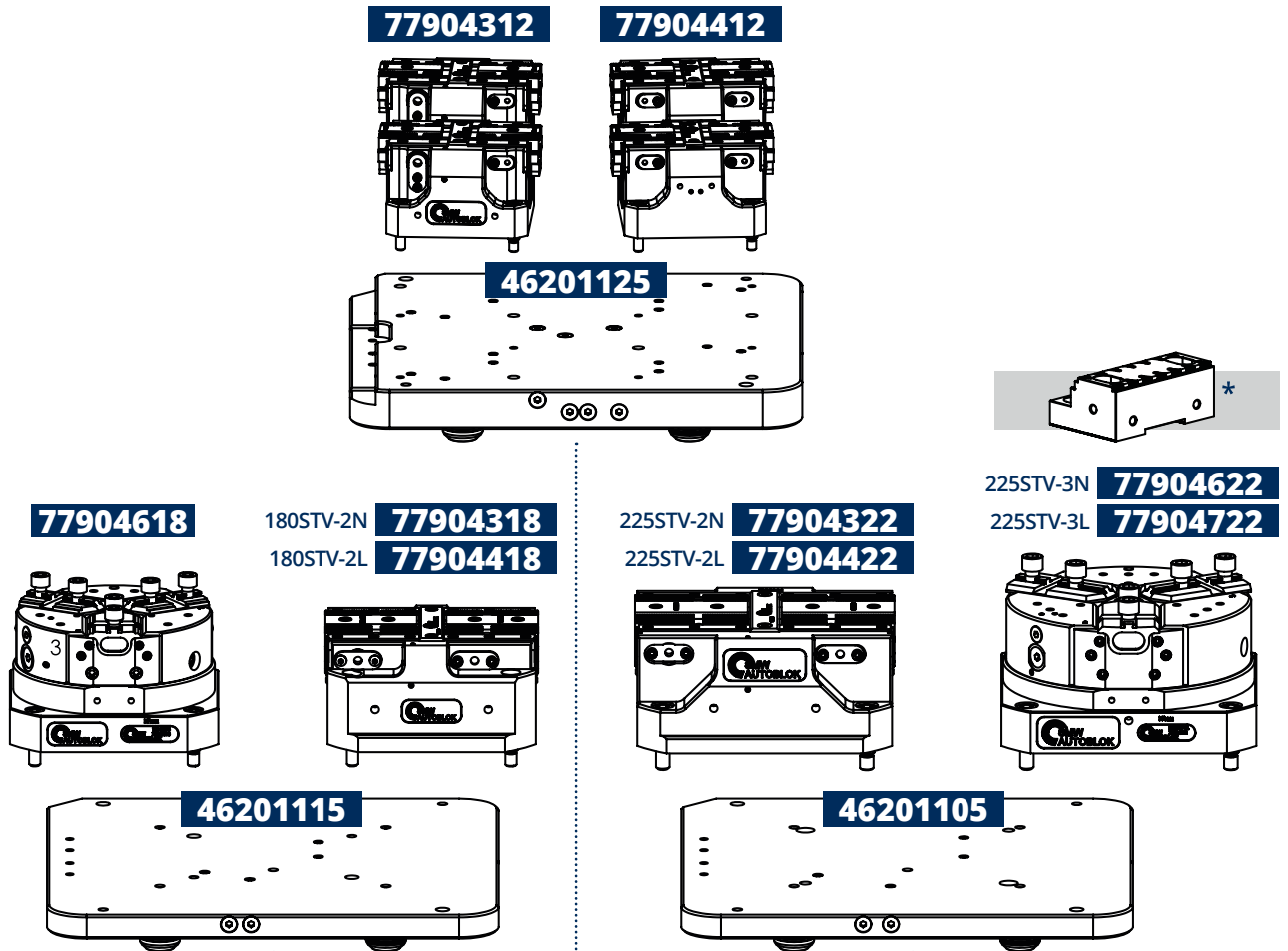

PORT3 = STV vise opening (B)
PORT4 = STV vise closing (C)

REFER TO THE GRIPPERS
CHAPTERS

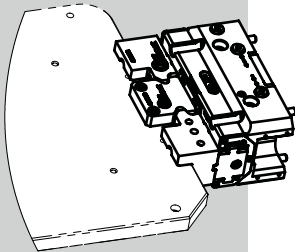

* SEE TWIN VISES
CATALOGUE

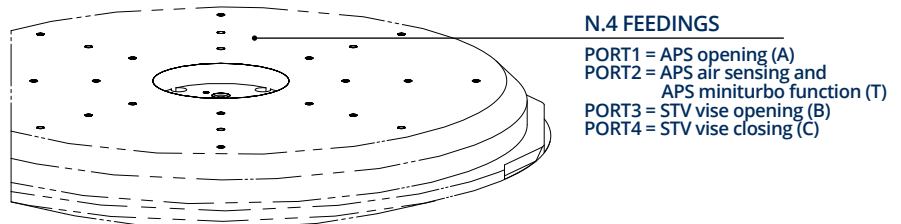
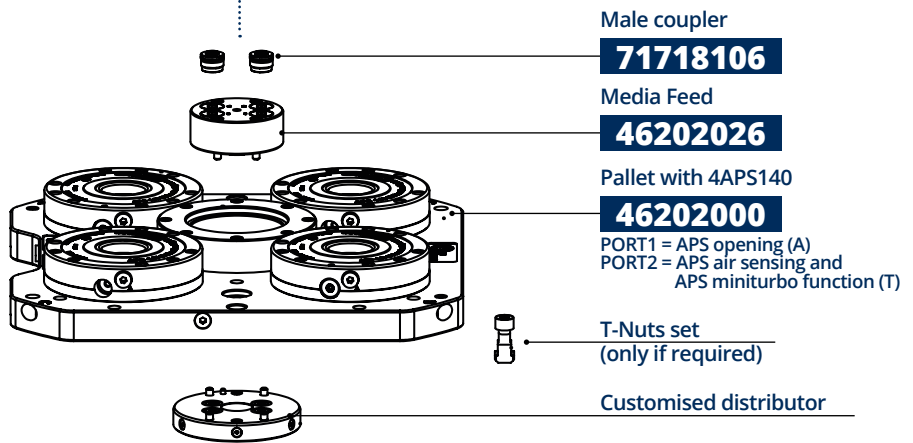
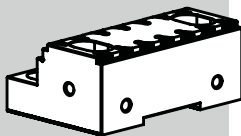

5 AXIS MACHINE SOLUTION WITH N.6 PNEUMATIC FEEDINGS: n.2 for APS control + n.4 for upper plate

Upper plate manual change or by robot
Workpiece manual loading or by robot

77904312

77904412

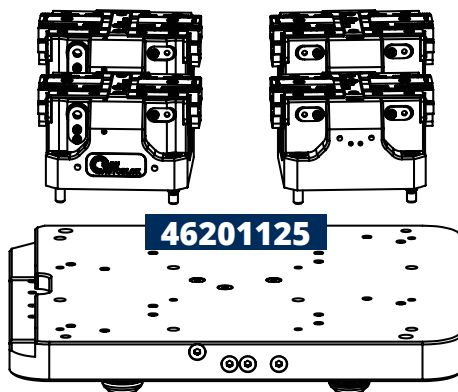

46201125

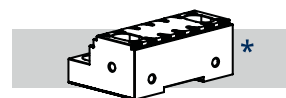

77904618

180STV-2N **77904318**

225STV-2N **77904322**

225STV-3N **77904622**

180STV-2L **77904418**

225STV-2L **77904422**

225STV-3L **77904722**

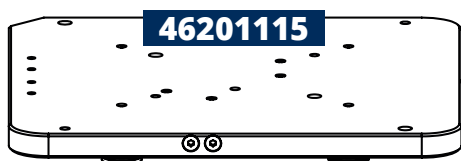
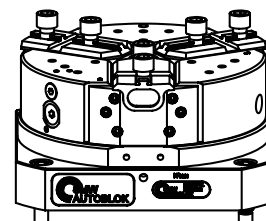
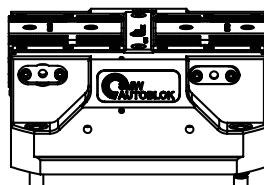
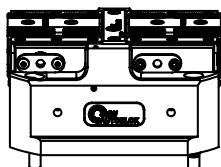
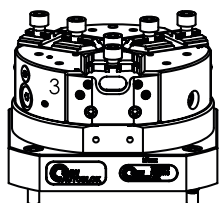

46201115

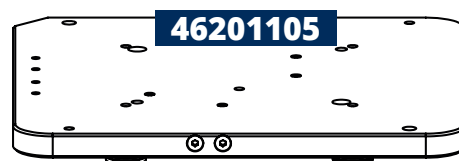

46201105

PORT3 = STV vise opening (B)
PORT4 = STV vise closing (C)
PORT5 = STV vise stroke control (D)
PORT6 = STV vise air sensing (E)

REFER TO THE GRIPPERS
CHAPTERS

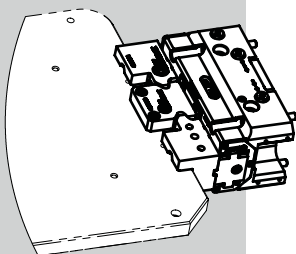

Male coupler

71718106

Media Feed

46202026

Pallet with 4APS140

46202000

PORT1 = APS opening (A)
PORT2 = APS air sensing and
APS miniturbo function (T)

T-Nuts set
(only if required)

Customised distributor

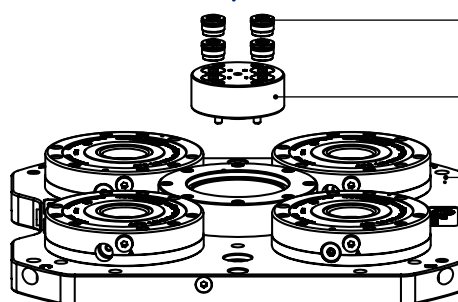

* SEE TWIN VISES
CATALOGUE

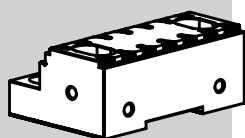

N.6 FEEDINGS

PORT1 = APS opening (A)
PORT2 = APS air sensing and
APS miniturbo function (T)
PORT3 = STV vise opening (B)
PORT4 = STV vise closing (C)
PORT5 = STV vise stroke control (D)
PORT6 = STV vise air sensing (E)

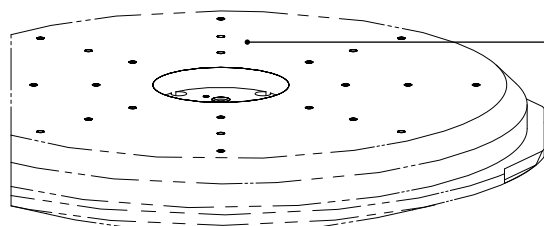

3 AXIS MACHINE SOLUTION WITH N.3 PNEUMATIC FEEDINGS for APS

Upper plate manual change or by robot

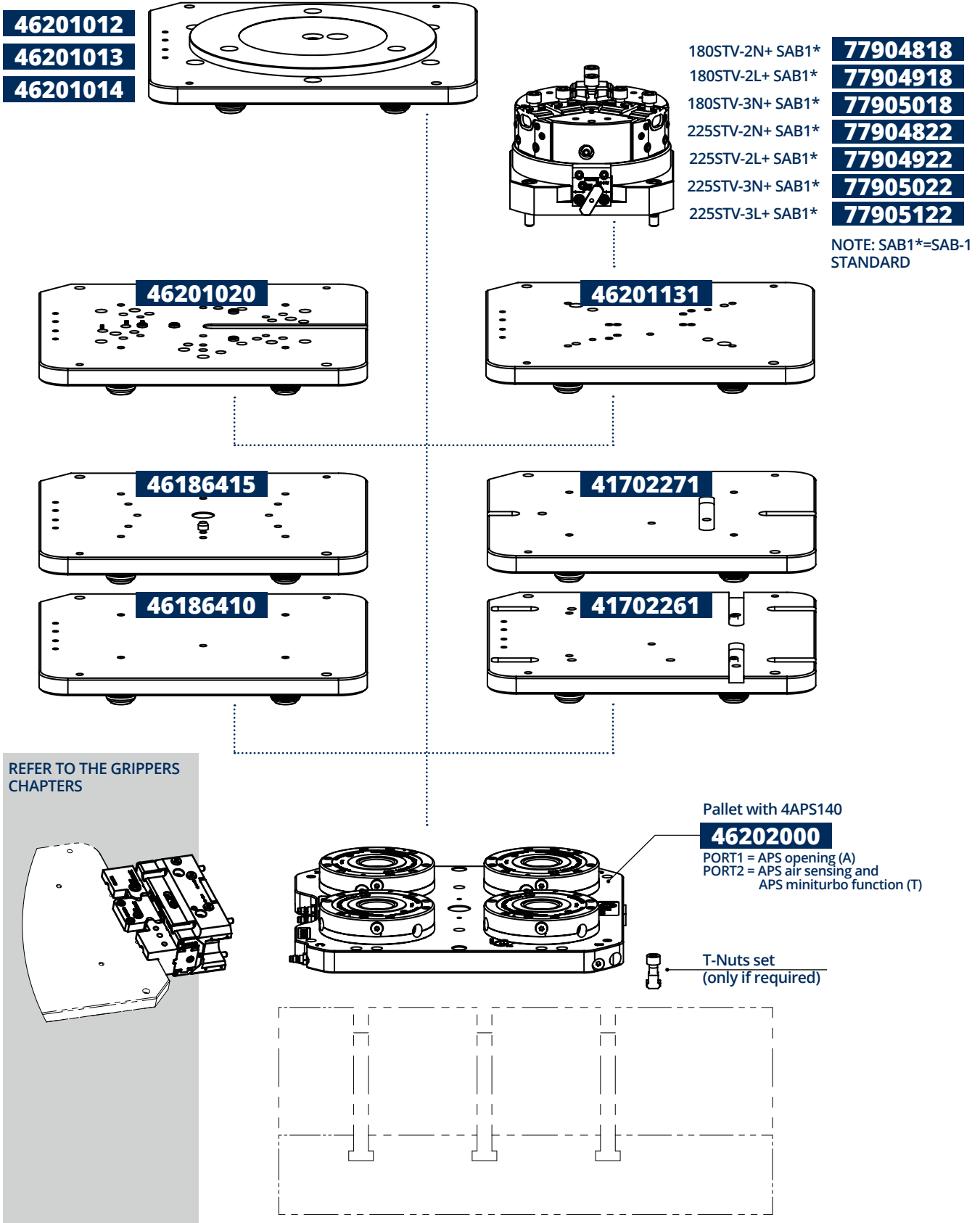

3 AXIS MACHINE SOLUTION WITH N.3 PNEUMATIC FEEDINGS for APS + n.4 for upper plate

Upper plate manual change or by robot
Workpiece manual loading or by robot

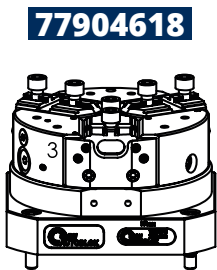
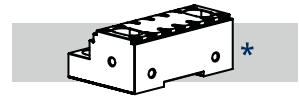
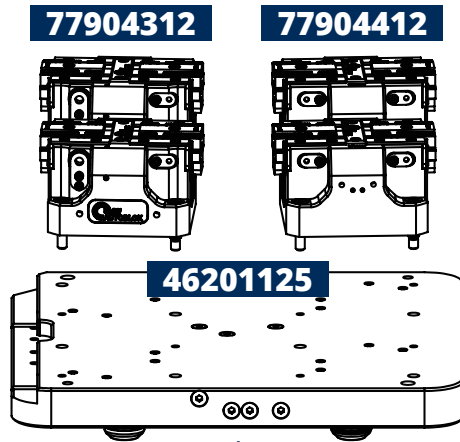

180STV-2N **77904318**
180STV-2L **77904418**

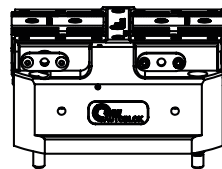

225STV-2N **77904322**
225STV-2L **77904422**

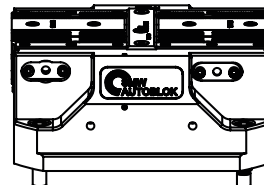

225STV-3N **77904622**
225STV-3L **77904722**

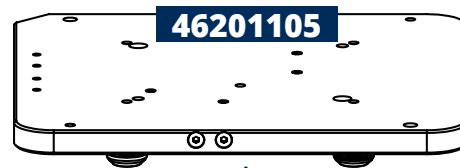
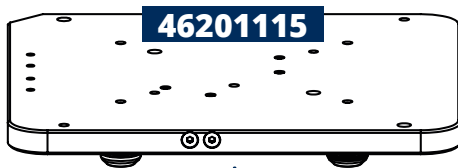
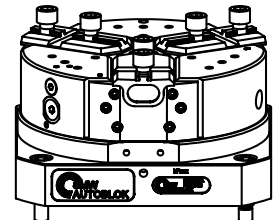

PORT3 = STV vise opening (B)
PORT4 = STV vise closing (C)
PORT5 = STV vise stroke control (D)
PORT6 = STV vise air sensing (E)

Male coupler

71718106

Media Feed

46202041

PORT4 = STV vise opening (B)
PORT5 = STV vise closing (C)
PORT6 = STV vise stroke control (D)
PORT7 = STV vise air sensing (E)
Pallet with 4APS140 SC

46202220

PORT1 = APS opening (A)
PORT2 = APS air sensing/minat. function (T)
PORT3 = APS stroke control (SC)

T-Nuts set

(only if required)

REFER TO THE GRIPPERS
CHAPTERS

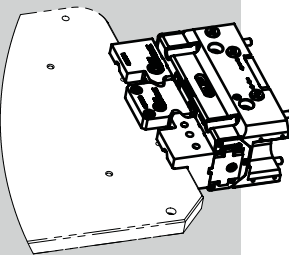

* SEE TWIN VISES
CATALOGUE

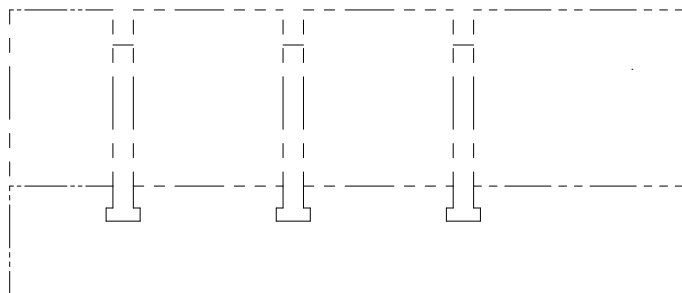
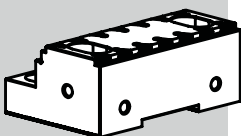

6

GRIPPERS - 2 or 3 jaws

126

2-GRIPPERS 2 JAWS - SUMMARY
THREE TYPES OF 2-GRIPPERS

a

128

PP 2-GRIPPERS

2 jaws self-centering protected grippers, steel body
Ø125-160-200-250

134

PL 2-GRIPPERS

2 jaws self-centering protected grippers, aluminium
body. Ø64-80-100-125-160-200-250

143

PL / PL-RR 2-GRIPPERS

2 jaws self-centering protected grippers
Ø320-380. Quick jaw change - optional

149

PP PL FINGERS FOR PALLET

PP / PL grippers fingers - features list.

156

**2PXS 2PXM 2PXL
2-UNIVERSAL GRIPPERS**

2 jaws self-centering grippers, aluminium-body

166

2PXS 2PXM 2PXL SENSORS

Inductive, analogics and magnetics sensors

168

3-GRIPPERS 3 JAWS - SUMMARY
TWO TYPES OF 3-GRIPPERS

b

170

3MN 3-GRIPPERS

3 jaws self-centering grippers, aluminium body
Ø64-80-100-125-160-200-250

179

3MN / 3MN-RR 3-GRIPPERS

3 jaws self-centering grippers.
Ø320-380. Quick jaw change - optional

186

3MN ANALOGIC SENSOR

Analogic inductive sensor for the linear jaw stroke
control (optional)

188

**3PXS 3PXM 3PXL
3-UNIVERSAL GRIPPERS**

3 jaws self-centering grippers, aluminium body

198

3PXS 3PXM 3PXL SENSORS

Inductive, analogics and magnetics sensors

200

FINGERS FOR GRIPPERS

Aluminium fingers for grippers.

a

b

GRIPPERS

with 2-jaws
for precise handling
of workpieces

THREE TYPES OF 2-GRIPPERS

PP

PL

2PXS
2PXM
2PXL

Type	Size									Jaws			Stroke		Quick jaw change	Clamping		
	64	80	100	125	160	200	250	320	380	n°	Tongue & Groove	Bush	Normal	Long		OD	ID	
PP				125						2			PP-N	PP-L				
					160					2			PP-N	PP-L				
						200				2			PP-N	PP-L				
							250			2			PP-N	PP-L				
PL	64									2				PL-L				
		80								2				PL-L				
			100							2				PL-L				
				125						2			PL-N	PL-L				
					160					2			PL-N	PL-L				
						200				2			PL-N	PL-L				
							250			2			PL-N	PL-L				
								320		2			PL-N-	PL-L-	RR			
									320	2			PLS-N-	PLS-L-	RR			
										380	2			PL-N-	PL-L-	RR		
										380	2			PLS-N-	PLS-L-	RR		
2PXS	64									2			2PXS-N	2PXS-L				
		80								2			2PXS-N	2PXS-L				
			100							2			2PXS-N	2PXS-L				
	64									2			2PXS-NS	2PXS-LS		E	I	
	80								2			2PXS-NS	2PXS-LS		E	I		
		100							2			2PXS-NS	2PXS-LS		E	I		
2PXM				125						2			2PXM-N	2PXM-L				
					160					2			2PXM-N	2PXM-L				
						200				2			2PXM-N	2PXM-L				
				125						2			2PXM-NS	2PXM-LS		E	I	
					160					2			2PXM-NS	2PXM-LS		E	I	
						200				2			2PXM-NS	2PXM-LS		E	I	
2PXL							250		2			2PXL-N	2PXL-L					
								250	2			2PXL-NS	2PXL-LS		E	I		

PP

2 jaws self-centering protected grippers with steel body Ø125-160-200-250

STEEL

Protected - Pneumatics - Hydraulics

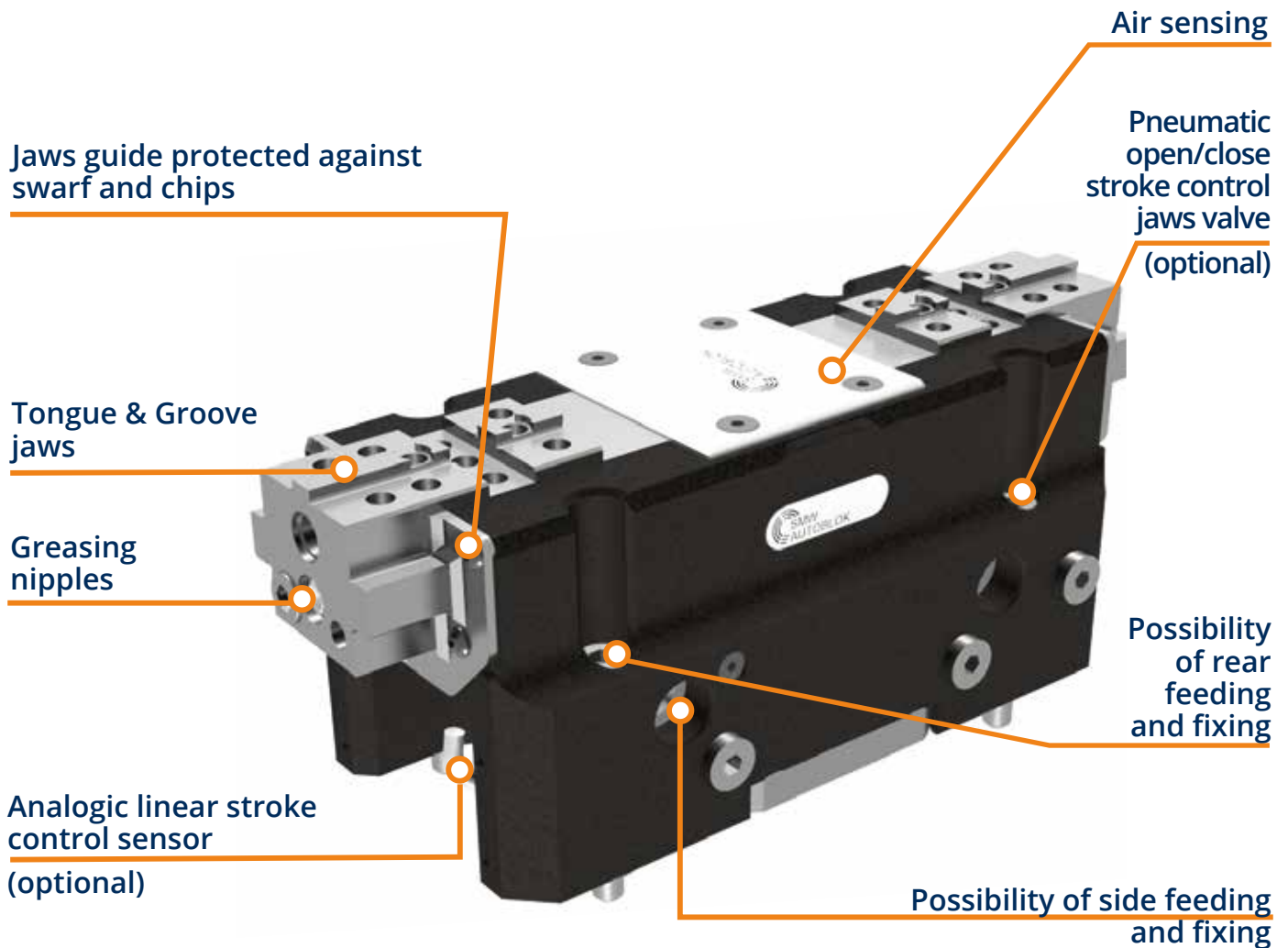

Applications /Customer benefits

- Pneumatic (max. 8 bar) as well as hydraulic (max. 30 bar) use
- OD and/or ID clamping
- Side or rear feeding and fixing
- Integrated greasing system on jaws (use SMW-Autoblok K67 grease)
- Possibility of element presence control (air sensing)

Standard equipment

Grippers without fingers and without sensors. All screws for the double mounting, all centering bushings and all interface OR included

Technical features

- Body and functional parts steel hardened for high precision and long life
- Tongue & Groove jaws
- Protection class IP64
- Highest rigidity and repeatability: see table
- Prepared for air purge

OPTIONAL

- Pneumatic stroke control valve
- Analogue linear stroke control sensor

PP grippers technical data

SMW-Autoblok Type	Id.No.	Clamping force (daN)		U (mm) jaw stroke	Pressure (bar) min./max.		Weight (Kg)	Recommended workpiece weight (Kg)		Repeatability (mm)	e (mm) min./max.	R1 (mm) min./max.	R2 (mm) min./max.
		at 6 bar PN	at 30 bar H		PN	H		PN	H				
PP-N 125	77901862	290	1460	5,5	3/8	8/30	4,9	14,5	73	0,01	47,5/53	72/77,5	24,5/30
PP-L 125	77901962	130	650	13	3/8	8/30	4,9	6,5	32,5	0,01	47,5/60,5	72/85	24,5/37,5
PP-N 160	77901866	400	1900	5,5	3/8	8/30	5,7	20	95	0,01	62,5/68	87/92,5	24,5/30
PP-L 160	77901966	170	840	13	3/8	8/30	5,7	8,5	42	0,01	62,5/75,5	87/100	24,5/37,5
PP-N 200	77901870	580	2850	7	3/8	8/30	11	29	142,5	0,02	62,5/69,5	106/113	37/44
PP-L 200	77901970	250	1270	16,5	3/8	8/30	11	12,5	63,5	0,02	62,5/79	106/122,5	37/53,5
PP-N 250	77901875	870	4370	10	3/8	8/30	19,5	43,5	218,5	0,02	78/88	131/141	48/58
PP-L 250	77901975	320	1580	29,8	3/8	8/30	19,5	16	79	0,02	78/107,8	131/160,8	48/77,8

Note: PP-N: Normal stroke PP-L: Long stroke

Application examples PP grippers/vises

vise
use

hydraulic

grippers
use

pneumatic

125

PP

PNEUMATIC VERSION (6 bar)

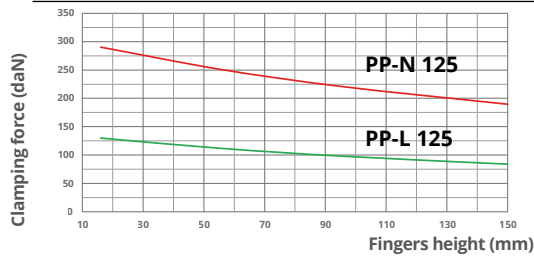

HYDRAULIC VERSION (30 bar)

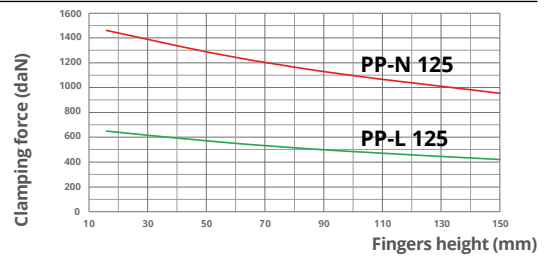

For fingers characteristics (height/weight), please contact SMW-Autoblok technical department.
 In I.D. clamping; consider +5% of the clamping force shown in the diagram.
 Use connecting screws class 12.9.



maximum allowed temperature using proximities is 60°C

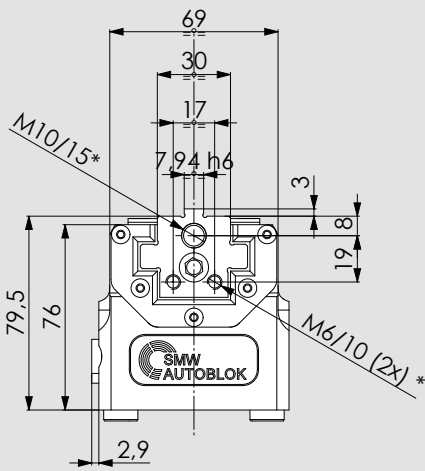
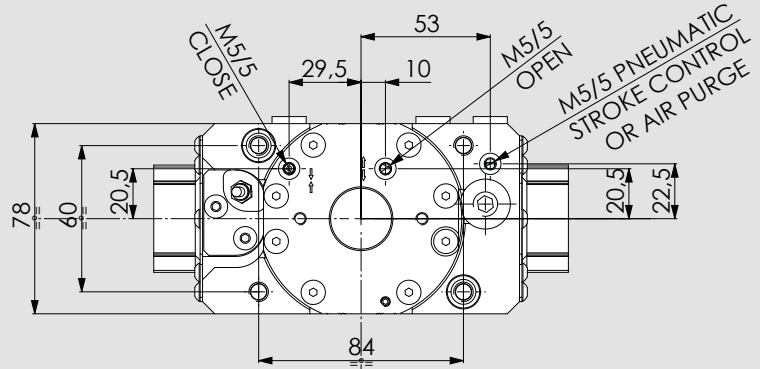

*: HOLES ONLY ON 125 PP-L VERSION

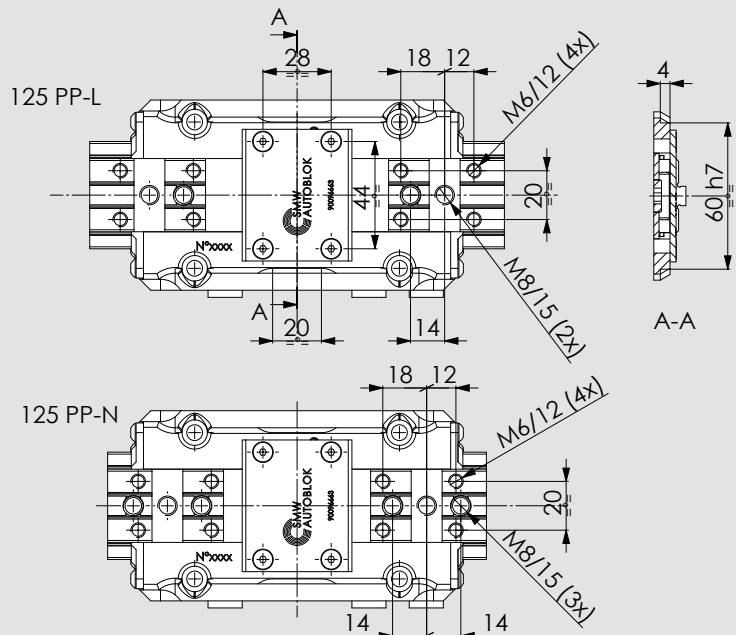
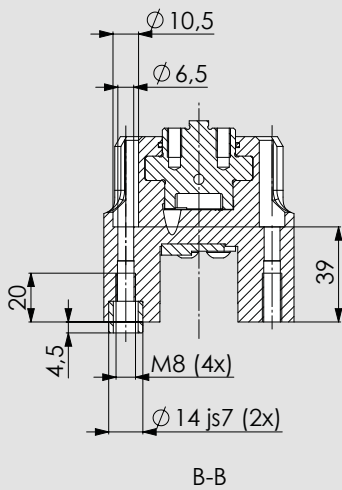
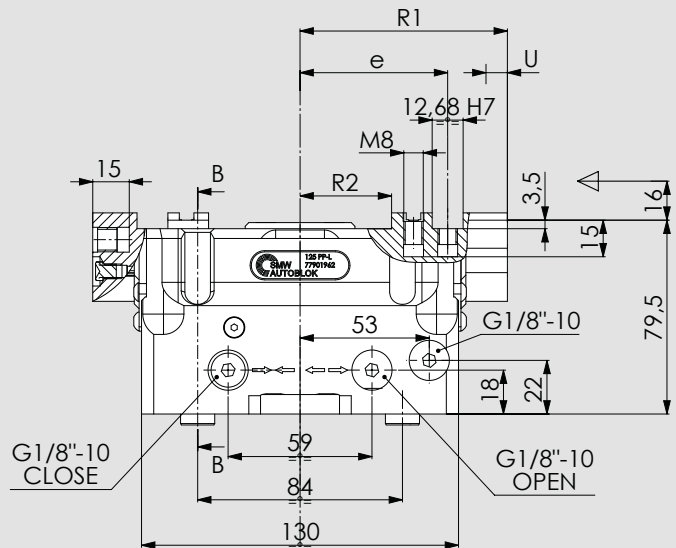

160

PP

PNEUMATIC VERSION (6 bar)

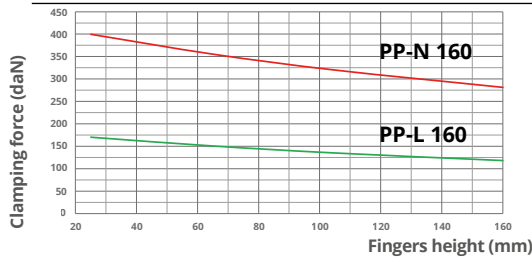

HYDRAULIC VERSION (30 bar)

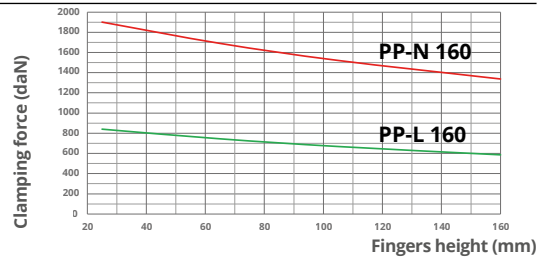

For fingers characteristics (height/weight), please contact SMW-Autoblok technical department.
In I.D. clamping: consider +5% of the clamping force shown in the diagram.
Use connecting screws class 12.9.



maximum allowed temperature using proximities is 60°C

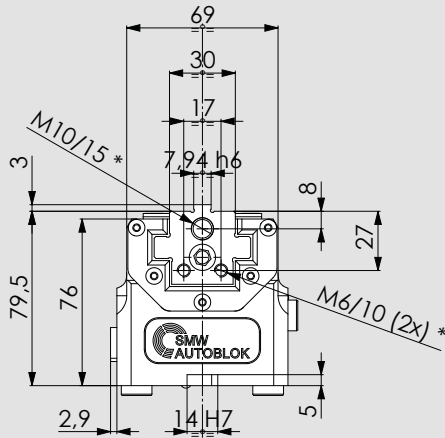

** HOLES ONLY ON 160 PP-L VERSION

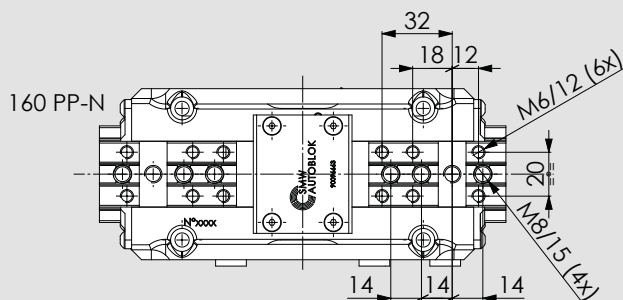
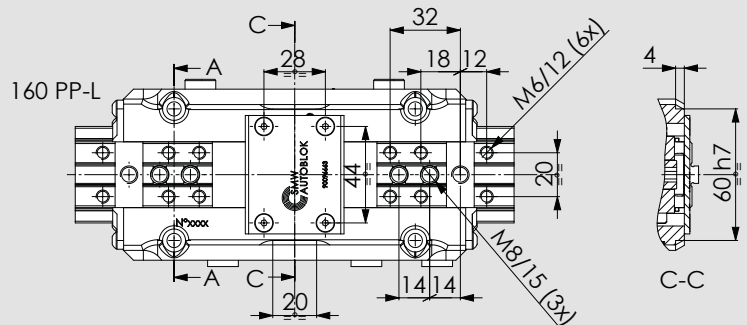
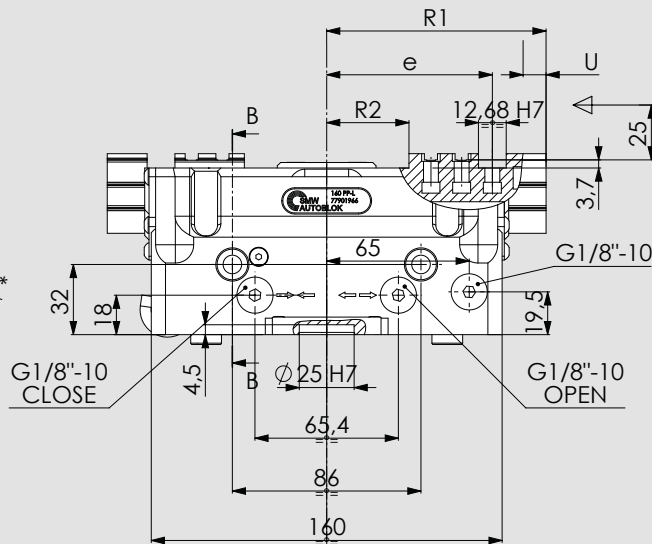
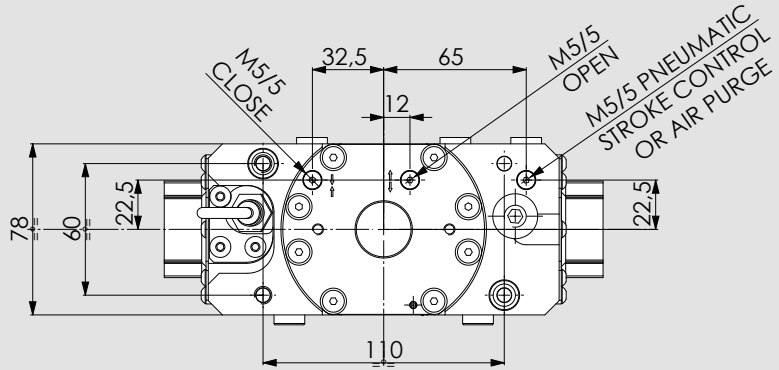
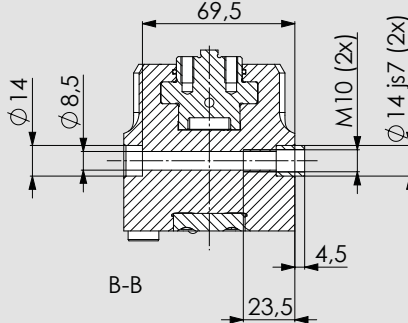
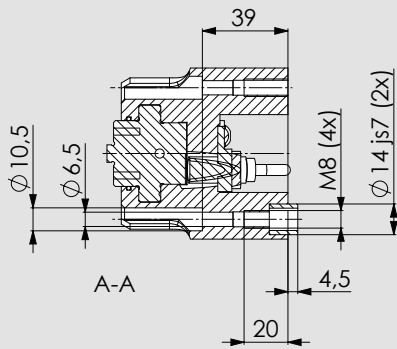

200

PP

PNEUMATIC VERSION (6 bar)

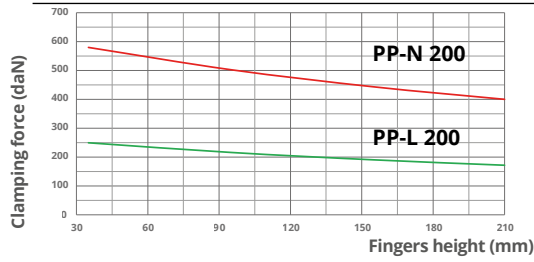

HYDRAULIC VERSION (30 bar)

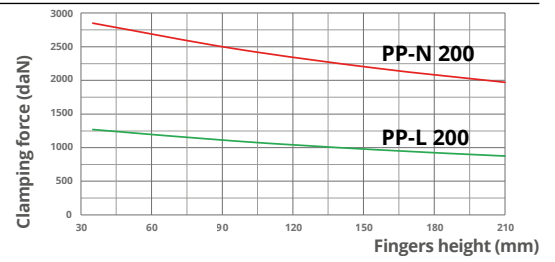

For fingers characteristics (height/weight), please contact SMW-Autoblok technical department.
 In I.D. clamping; consider +5% of the clamping force shown in the diagram.
 Use connecting screws class 12.9.



maximum allowed temperature using proximities is 60°C

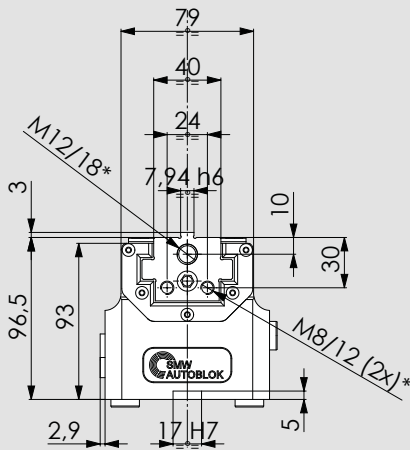
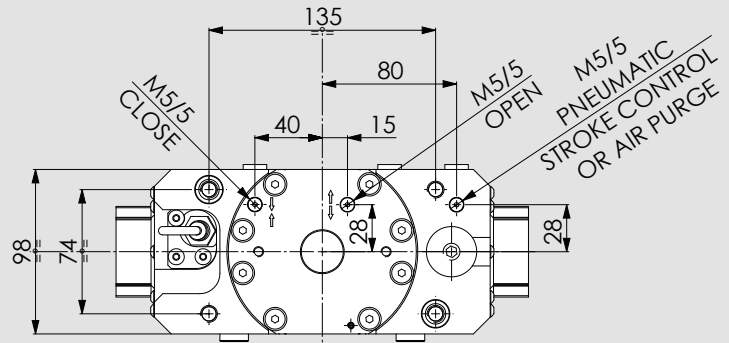

*: HOLES ONLY ON 200 PP-L VERSION

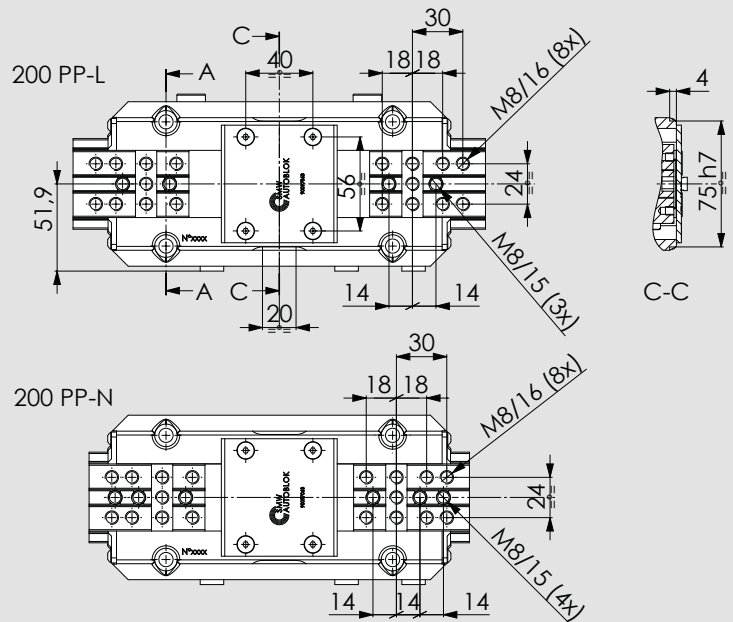
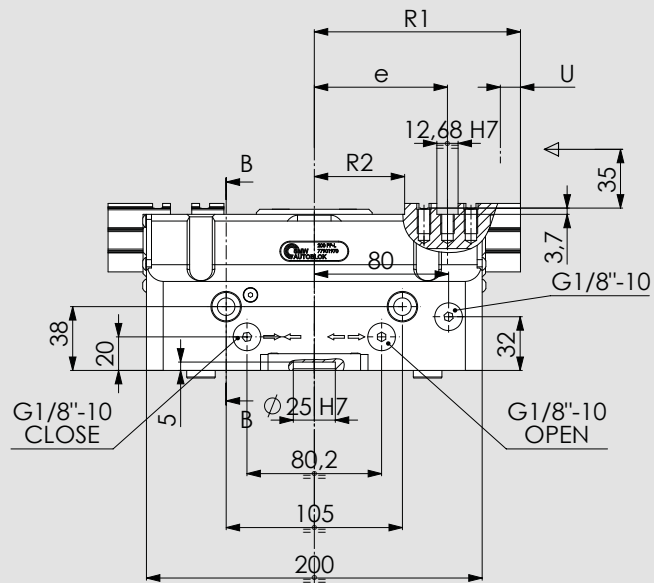
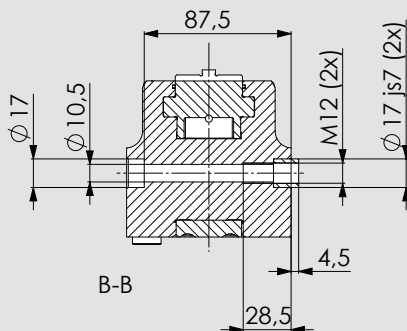
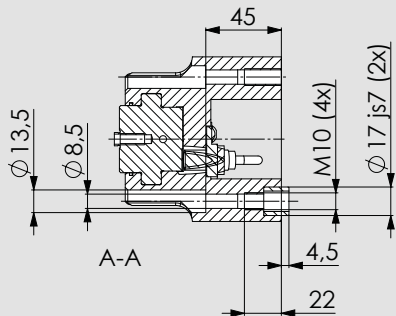

250

PP

PNEUMATIC VERSION (6 bar)

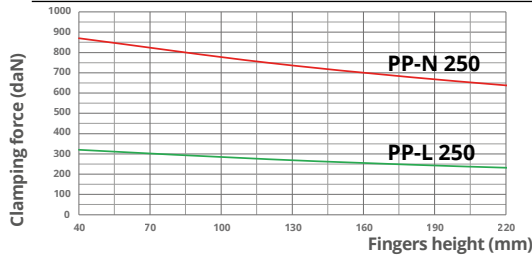

HYDRAULIC VERSION (30 bar)

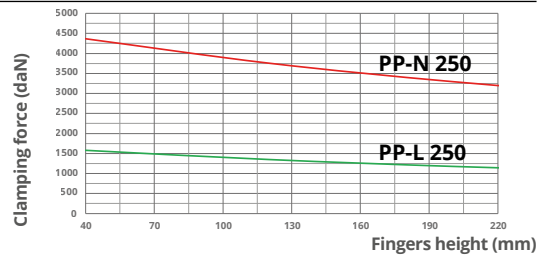

For fingers characteristics (height/weight), please contact SMW-Autoblok technical department.
In I.D. clamping: consider +3% of the clamping force shown in the diagram.
Use connecting screws class 12.9.



maximum allowed temperature using proximities is 60°C

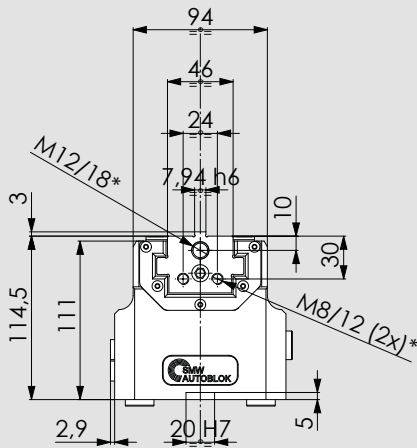
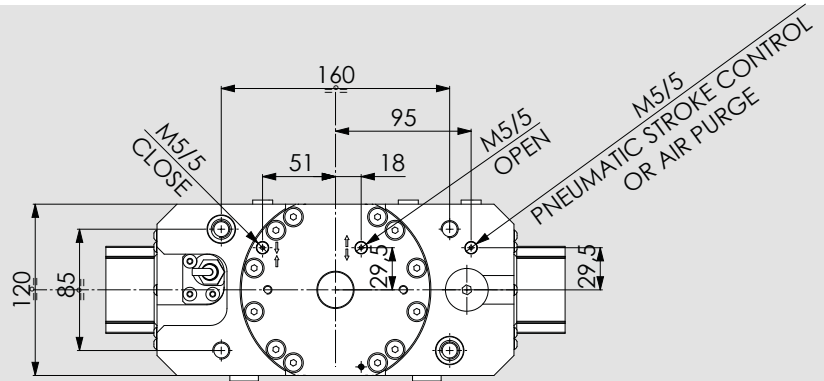

*: HOLES ONLY ON 250 PP-L VERSION

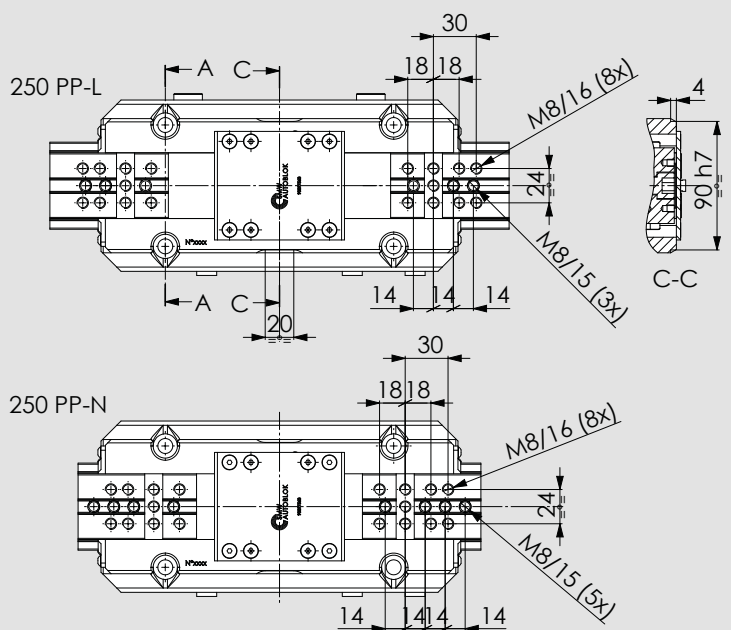
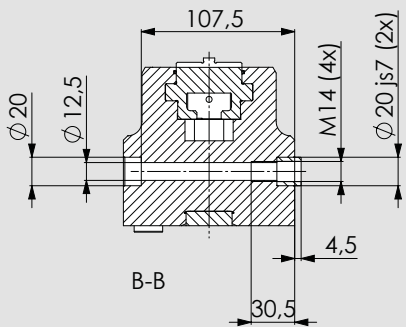
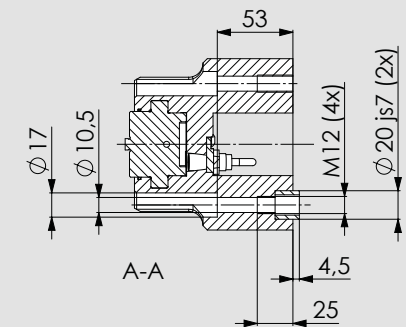
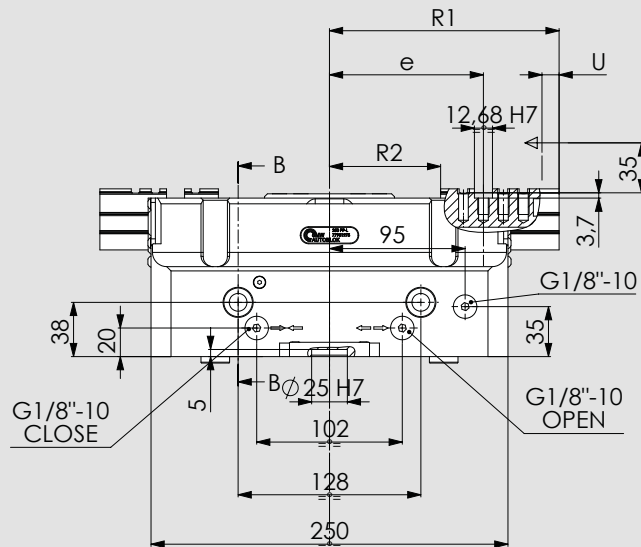

PL

2 jaws self-centering grippers Ø64-80-100

ALUMINIUM

Pneumatics - Protected



Technical features

- Aluminium body to contain the gripper weight
- Functional parts heat-treated for high precision and long life
- Jaws with calibrated bushings and groove
- PL-L long stroke
- Protection class IP64
- Highest rigidity and Repeatability: 0,01 mm
- Prepared for Air purge

OPTIONAL

- Analogic linear stroke control sensor

Applications/Customer benefits

- Compact and light design
- OD and/or ID clamping
- Side or rear feeding and fixing
- Integrated greasing system on jaws (use SMW-Autoblok K67 grease)

Standard equipment

Grippers without fingers and without sensors.
All screws for the double mounting, all centering bushings and all interface OR included

SMW-Autoblok TYPE	Id. No.	Clamping force (daN) at 6 bar	U (mm) jaw stroke	Air volume (cm ³)	Pressure (bar) min./max.	Opening/ Closing time (s) at 6 bar	Weight (Kg)	Workpiece weight recommended (Kg)	e (mm) min. /max.	R1 (mm) min. /max.	R2 (mm) min. /max.
PL-L 64	77901957	30	6	8	2/8	0,03/0,03	0,5	1,5	14,25/20,25	47,5/53,5	9,75/15,75
PL-L 80	77901959	45	8	15	2/8	0,04/0,04	0,8	2,3	18,5/26,5	54,5/62,5	62,5/72,5
PL-L 100	77901961	70	10	30	2/8	0,07/0,07	1,3	3,5	23,5/33,5	62,5/72,5	17/27

80

PL

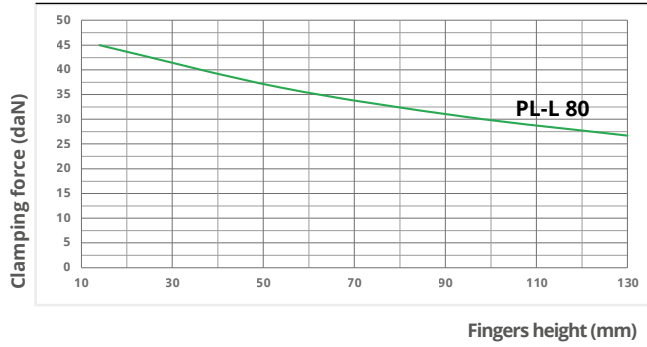

Clamping force calculated at **6 bar**.
 Max. recommended fingers height: **130 mm**
 Max. fingers weight: **0,7 Kg**
 For I.D. clamping consider **+10%** of the clamping force shown in the diagram.
 Use connecting screws **class 12.9**

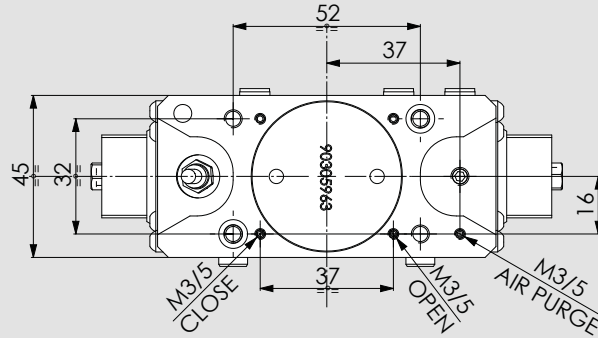
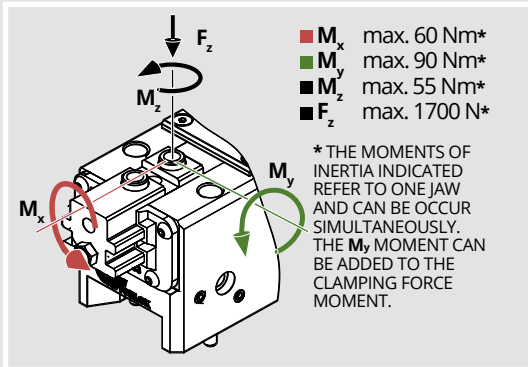

maximum allowed temperature using proximities is 60°C

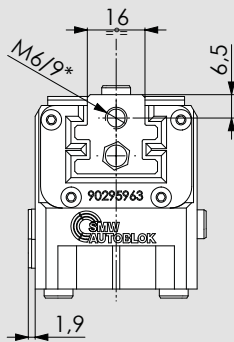

*: HOLES ONLY ON 80 PL-L VERSION

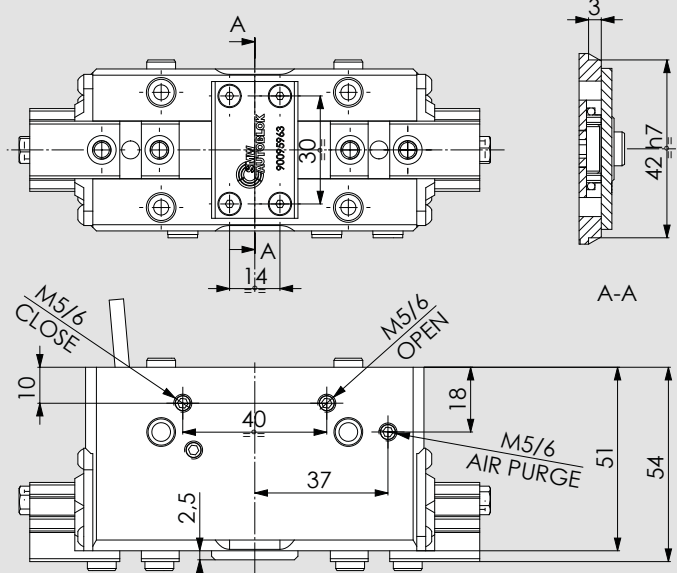
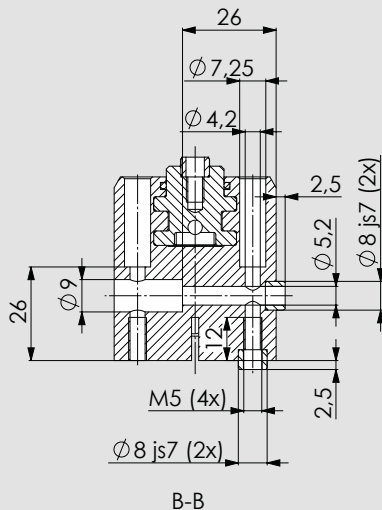
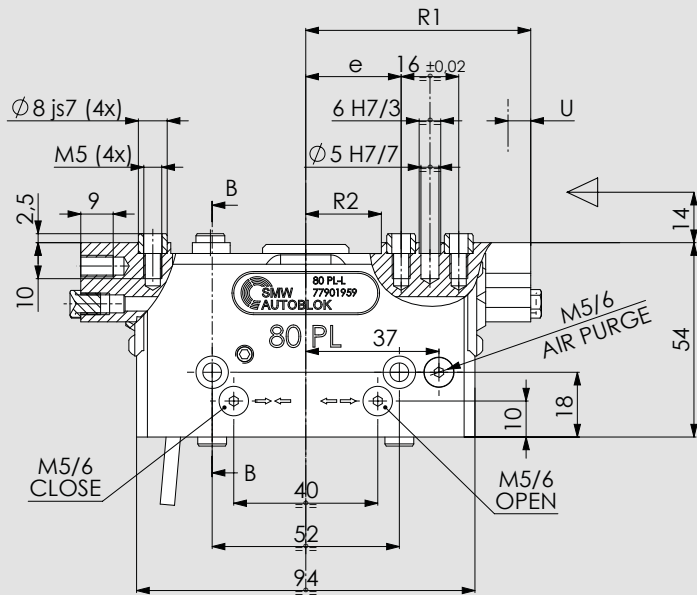

100

PL

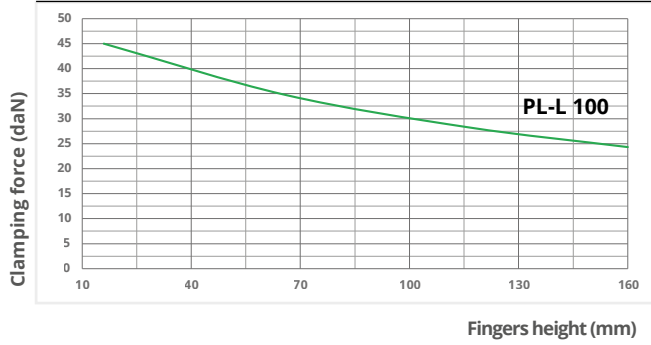

Clamping force calculated at **6 bar**.
Max. recommended fingers height: **160 mm**
Max. fingers weight: **1,2 Kg**
For I.D. clamping consider **+7%** of the clamping force shown in the diagram.
Use connecting screws **class 12.9**

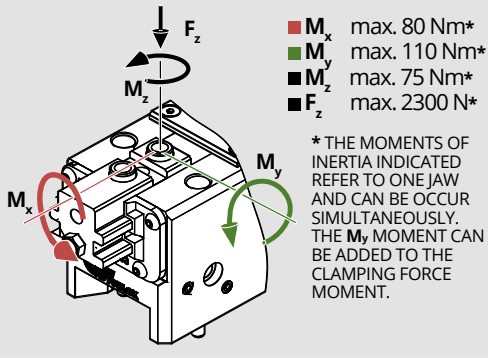

+10°C +70°C
maximum allowed temperature using proximities is 60°C

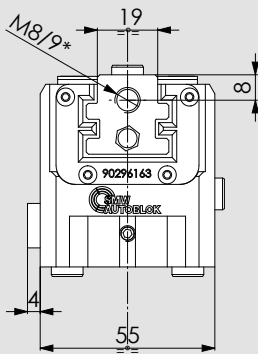

*: HOLES ONLY ON 100 PL-L VERSION

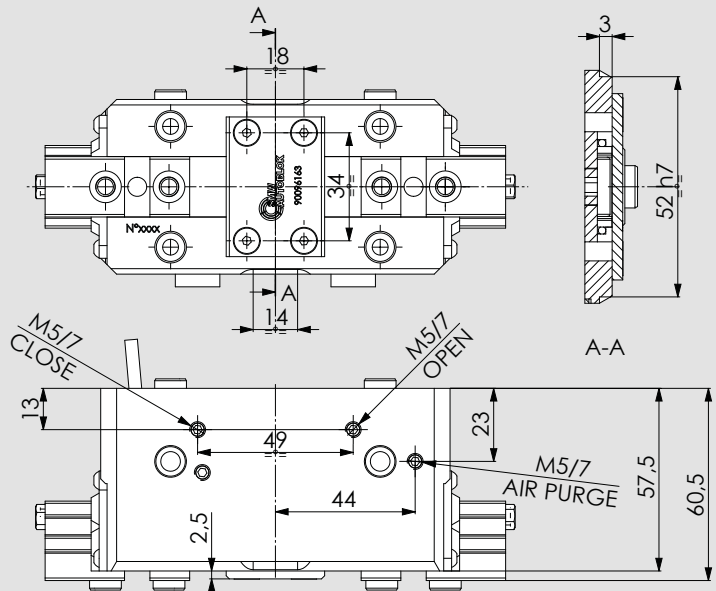
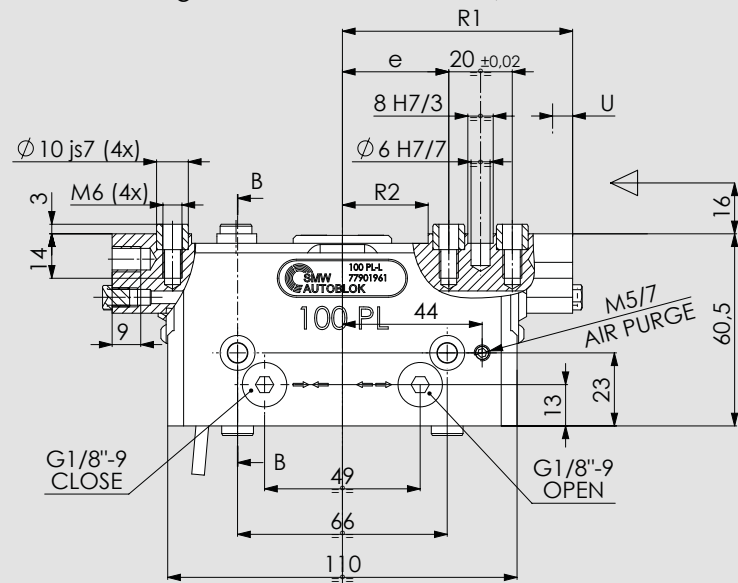
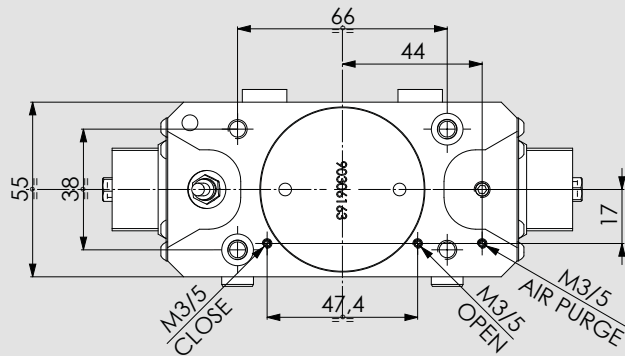
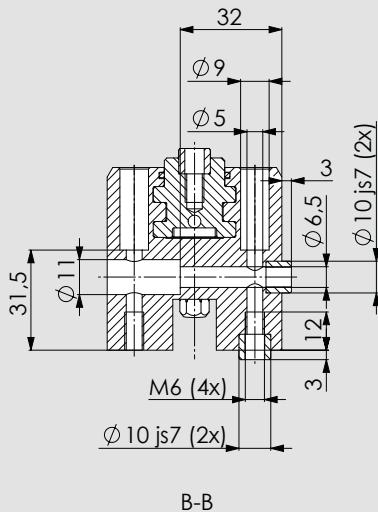

PL

2 jaws self-centering grippers Ø125-160-200-250

ALUMINIUM

Pneumatics - Protected



Technical features

- Aluminium body to contain the gripper weight
- Functional parts heat-treated for high precision and long life
- Tongue & Groove jaws
- PL-N: Normal stroke PL-L: Long stroke
- Protection class IP64
- Highest rigidity and Repeatability: 0,02 mm
- Prepared for Air purge

OPTIONAL

- Analogic linear stroke control sensor
- Pneumatic stroke control valve

Applications/Customer benefits

- Compact and light design
- OD and/or ID clamping
- Side or rear feeding and fixing
- Integrated greasing system on jaws (use SMW-Autoblok K67 grease)

Standard equipment

Grippers without fingers and without sensors.
All screws for the double mounting, all centering bushings and all interface OR included

SMW-Autoblok TYPE	Id. No.	Clamping force (daN) at 6 bar	U (mm) jaw stroke	Air volume (cm ³)	Pressure (bar) min./max.	Opening/ Closing time (s) at 6 bar	Weight (Kg)	Workpiece weight recommended (Kg)	e (mm) min. /max.	R1 (mm) min. /max.	R2 (mm) min. /max.
PL-N 125	77901863	290	5,5	79,5	2/8	0,1/0,1	3	14,5	47,5/53	72/77,5	24,5/30
PL-L 125	77901963	130	13	79,5	2/8	0,1/0,1	3	6,5	47,5/60,5	72/85	24,5/37,5
PL-N 160	77901867	400	5,5	102	2/8	0,14/0,14	3,6	20,0	62,5/68	87/92,5	24,5/30
PL-L 160	77901967	170	13	102	2/8	0,14/0,14	3,6	8,5	62,5/75,5	87/100	24,5/37,5
PL-N 200	77901871	580	7	200	2/8	0,3/0,3	6,5	29,0	62,5/69,5	106/113	37/44
PL-L 200	77901971	250	16,5	200	2/8	0,3/0,3	6,5	12,5	62,5/79	106/122,5	37/53,5
PL-N 250	77901876	870	10	422,5	2/8	0,45/0,45	11	43,5	78/88	131/141	48/58
PL-L 250	77901976	320	29,8	422,5	2/8	0,45/0,45	11	16,0	78/107,8	131/160,8	48/77,8

125

PL

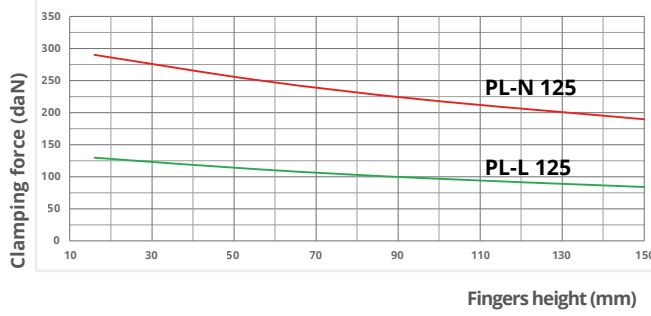

Clamping force calculated at **6 bar**.
For I.D. clamping consider **+5%** of the clamping force shown in the diagram.
Use connecting screws **class 12.9**
For fingers characteristics (height/weight), please contact SMW-Autoblok technical department.



maximum allowed temperature using proximities is **60°C**

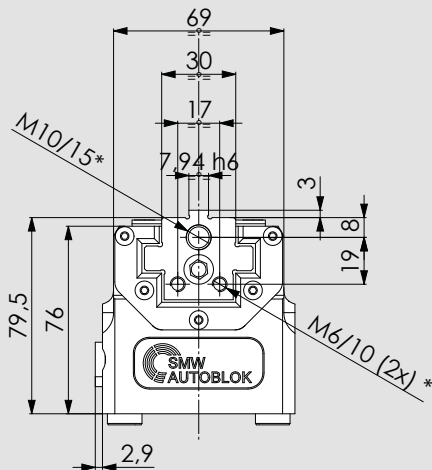
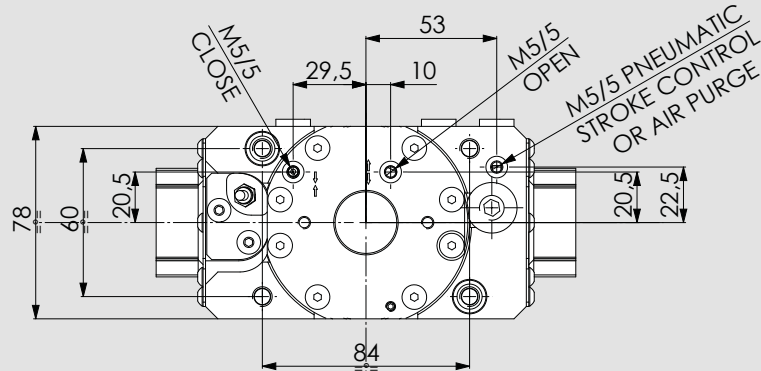

*: HOLES ONLY ON 125 PL-L VERSION

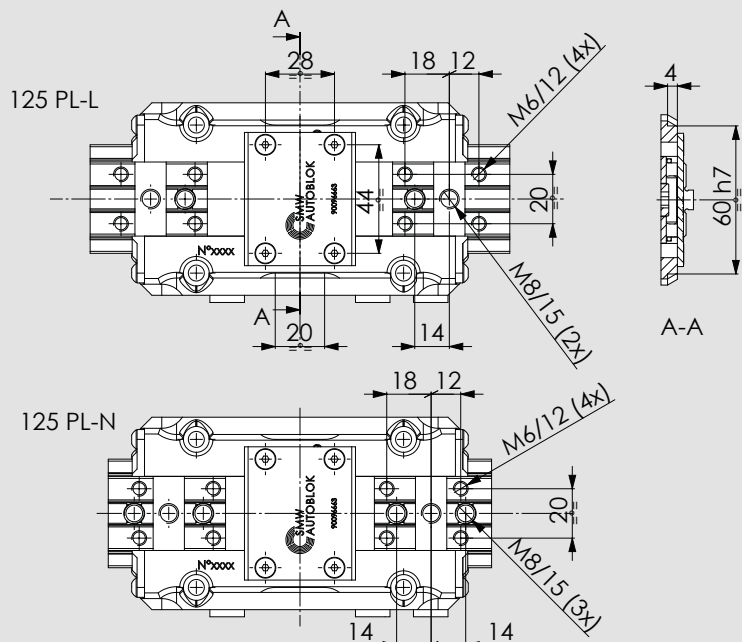
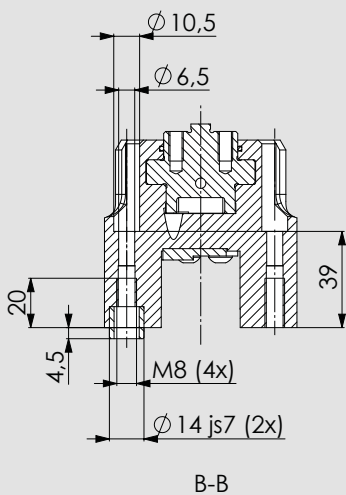
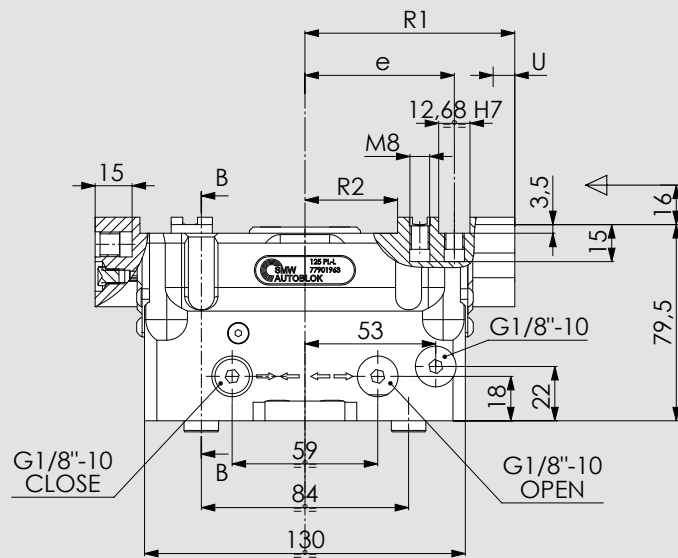

160

PL

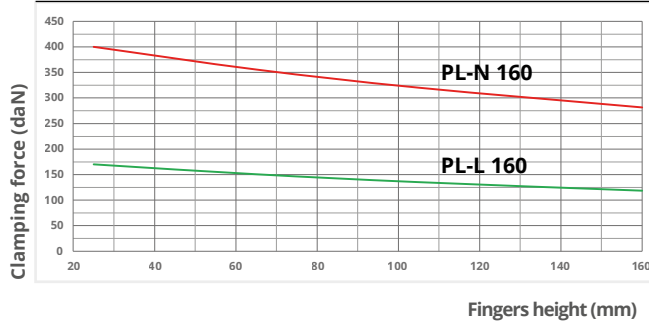

Clamping force calculated at 6 bar.
For I.D. clamping consider +5% of the clamping force shown in the diagram.
Use connecting screws class 12.9
For fingers characteristics (height/weight), please contact SMW-Autoblok technical department.



maximum allowed temperature using proximities is 60°C

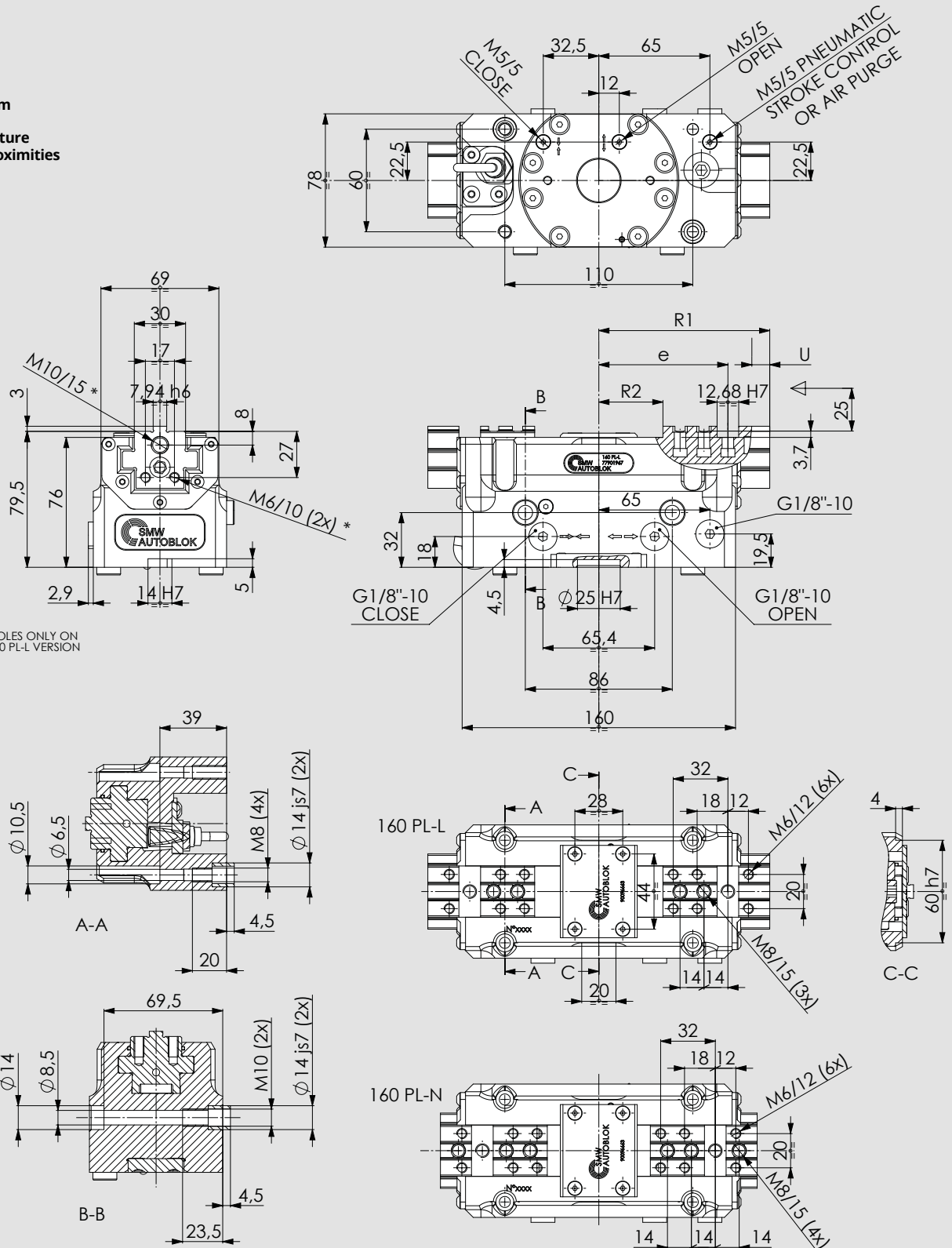

200

PL

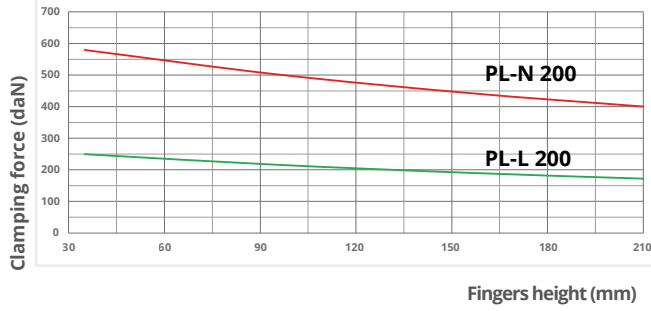

Clamping force calculated at **6 bar**.

For I.D. clamping consider **+5%** of the clamping force shown in the diagram.

Use connecting screws **class 12.9**

For fingers characteristics (height/weight), please contact SMW-Autoblok technical department.



maximum allowed temperature using proximities is **60°C**

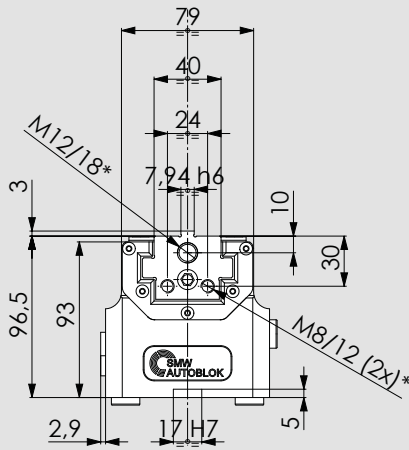
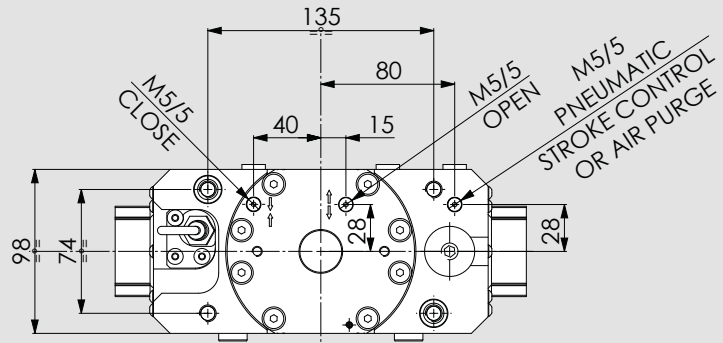

*: HOLES ONLY ON 200 PL-L VERSION

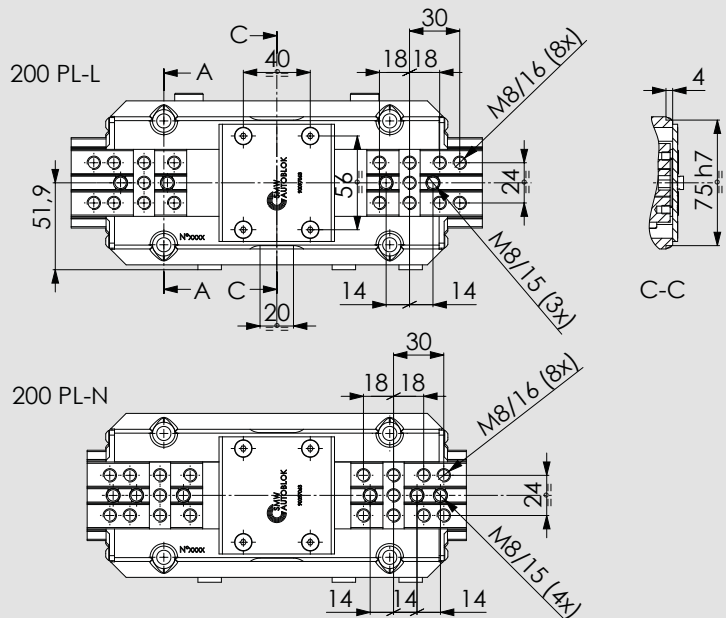
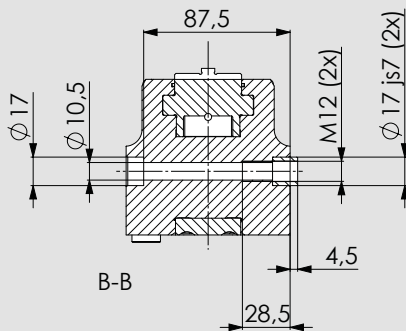
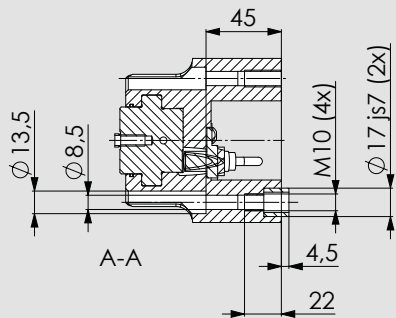
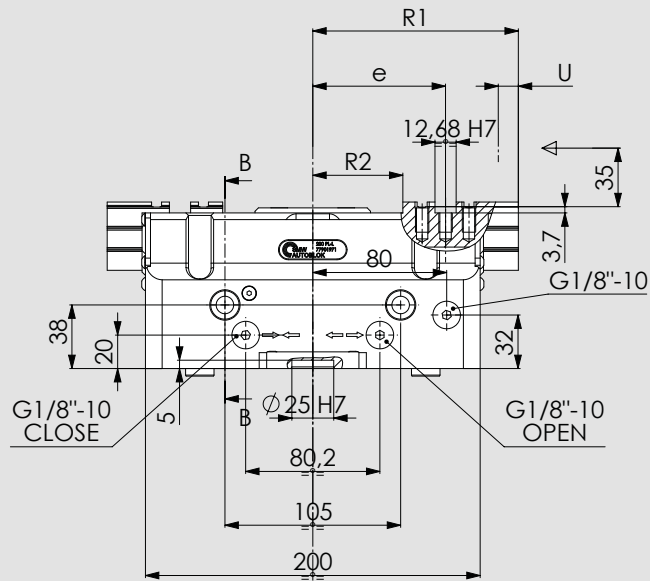

250

PL

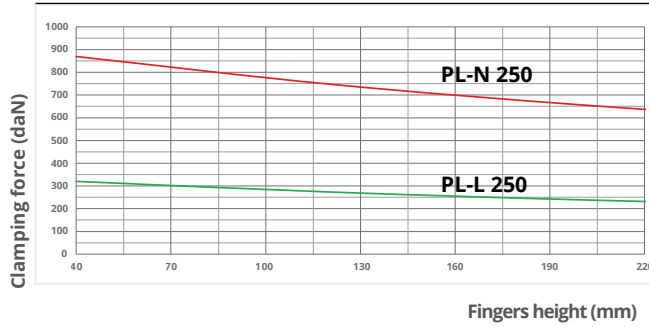

Clamping force calculated at **6 bar**.
For I.D. clamping consider **+3%** of the clamping force shown in the diagram.
Use connecting screws **class 12.9**
For fingers characteristics (height/weight), please contact SMW-Autoblok technical department.



maximum allowed temperature using proximities is 60°C

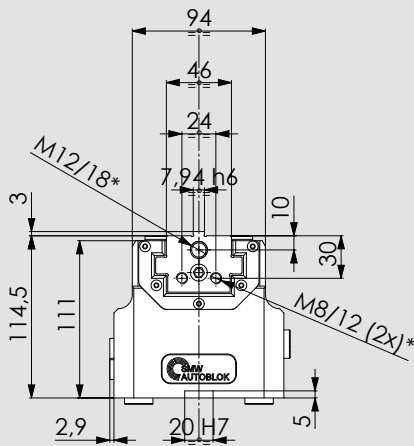
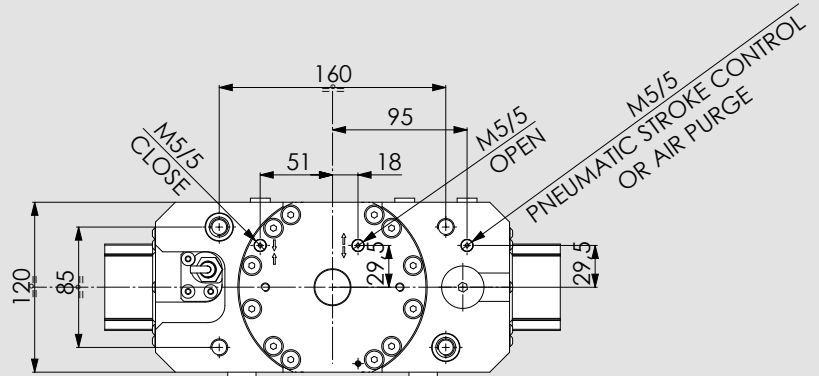

*: HOLES ONLY ON 250 PL-L VERSION

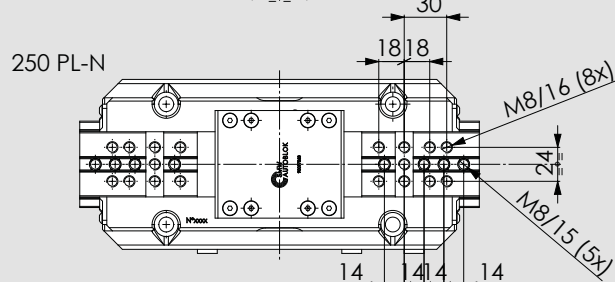
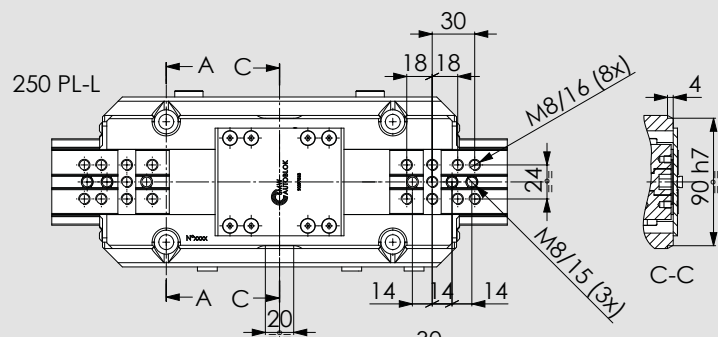
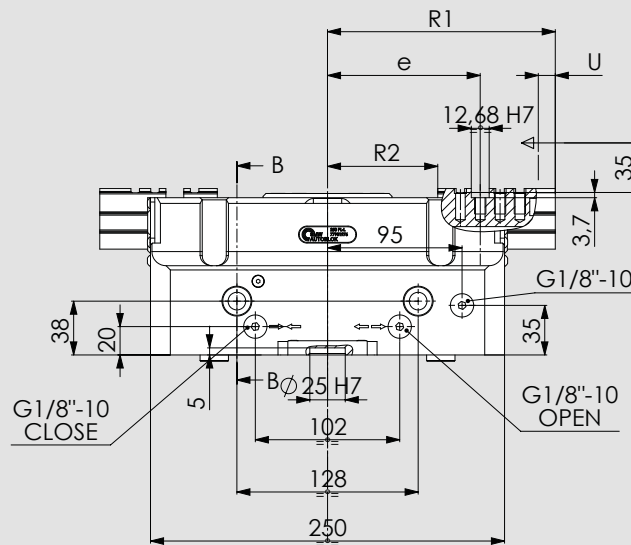
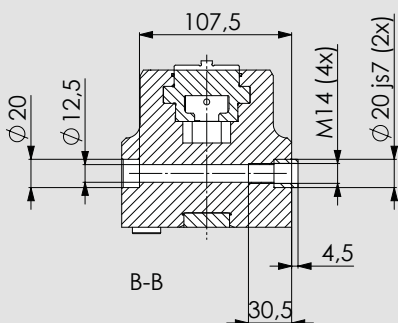
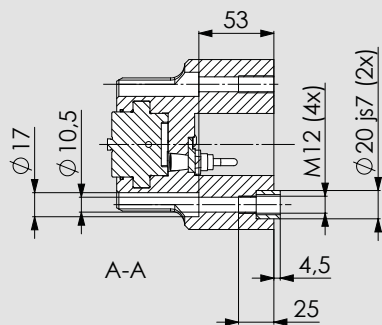

PL

2 jaws self-centering grippers Ø320-380

ALUMINIUM

Pneumatics - Protected - Quick jaws change

Technical features

- Aluminium body to contain the gripper weight
- Functional parts heat-treated for high precision and long life
- Jaws with calibrated bushings and groove
- Protection class IP64
- Highest rigidity and Repeatability: 0,04 mm
- Prepared for Air purge

OPTIONAL

- Analogic linear stroke control sensor
- Quick change jaws RR

Applications/Customer benefits

- Compact and light design
- OD and/or ID clamping
- Side or rear feeding and fixing
- Integrated greasing system on jaws (use SMW-Autoblok K67 grease)

Standard equipment

Grippers without fingers and without sensors.
All screws for the double mounting, all centering bushings and all interface OR included.

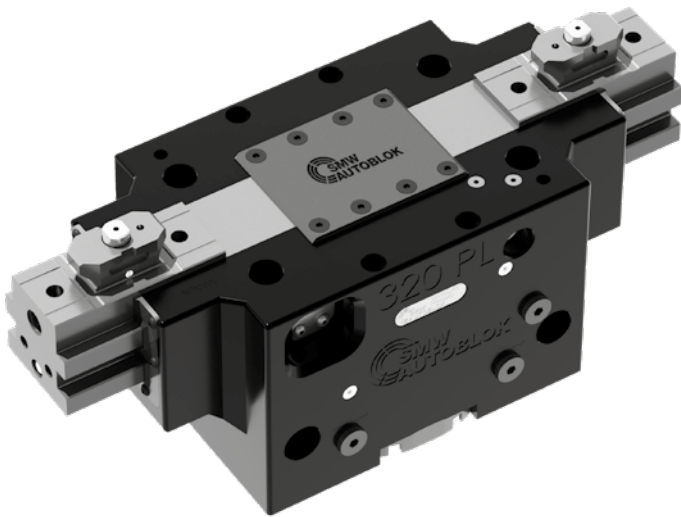

SMW-Autoblok TYPE	Id. No.	Clamping force (daN) at 6 bar	Spring force min. (daN)	U (mm) jaw stroke	Air volume (cm³)	Pressure (bar) min./max.	Opening/ Closing time (s) at 6 bar	Weight (Kg)	Workpiece weight recommended (Kg)	e (mm) min./max.	R1 (mm) min./max.	R2 (mm) min./max.
PL-N 320	77901883	1100	----	23,5	1206,5	2/8	0,5/0,5	27,5	55,0	79,5/103	173/196,5	60/83,5
PL-N 320 RR	77902583									116,5/140		
PLS-N 320	77902083	1430	330	23,5	1206,5	4/6,5	0,7/0,4	28	55,0	79,5/103	173/196,5	60/83,5
PLS-N 320 RR	77902783									116,5/140		
PL-L 320	77901983	600	----	45	1206,5	2/8	0,5/0,5	28	30,0	79,5/124,5	173/218	58/103
PL-L 320 RR	77902683									116,5/161,5		
PLS-L 320	77902183	780	180	45	1206,5	4/6,5	0,7/0,4	28,5	30,0	79,5/124,5	173/218	58/103
PLS-L 320 RR	77902883									116,5/161,5		
PL-N 380	77901889	1690	----	26	2060	2/8	0,6/0,6	41,5	84,5	90/116	197/223	70/96
PL-N 380 RR	77902589									140,5/166,5		
PLS-N 380	77902089	2220	530	26	2060	4/6,5	0,9/0,5	42,5	84,5	90/116	197/223	70/96
PLS-N 380 RR	77902789									140,5/166,5		
PL-L 380	77901989	925	----	50	2060	2/8	0,6/0,6	42,5	46,5	90/140	197/247	56,5/106,5
PL-L 380 RR	77902689									140,5/190,5		
PLS-L 380	77902189	1215	290	50	2060	4/6,5	0,9/0,5	43,5	46,5	90/140	197/247	56,5/106,5
PLS-L 380 RR	77902889									140,5/190,5		

Note: PL-N: Normal stroke PL-L: Long stroke PLS-N: Normal stroke with springs PLS-L: Long stroke with springs

320

PL

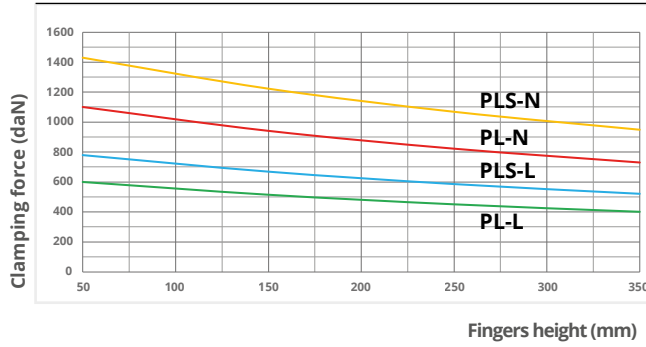

Clamping force calculated at **6 bar**.
 Max. recommended fingers height: **350 mm**
 Max. fingers weight: **12 Kg**
 For I.D. clamping consider **+3%** of the clamping force shown in the diagram.
 Use connecting screws **class 12.9**

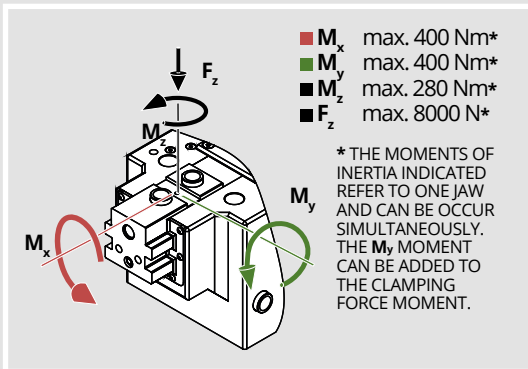

maximum allowed temperature using proximities is **60°C**

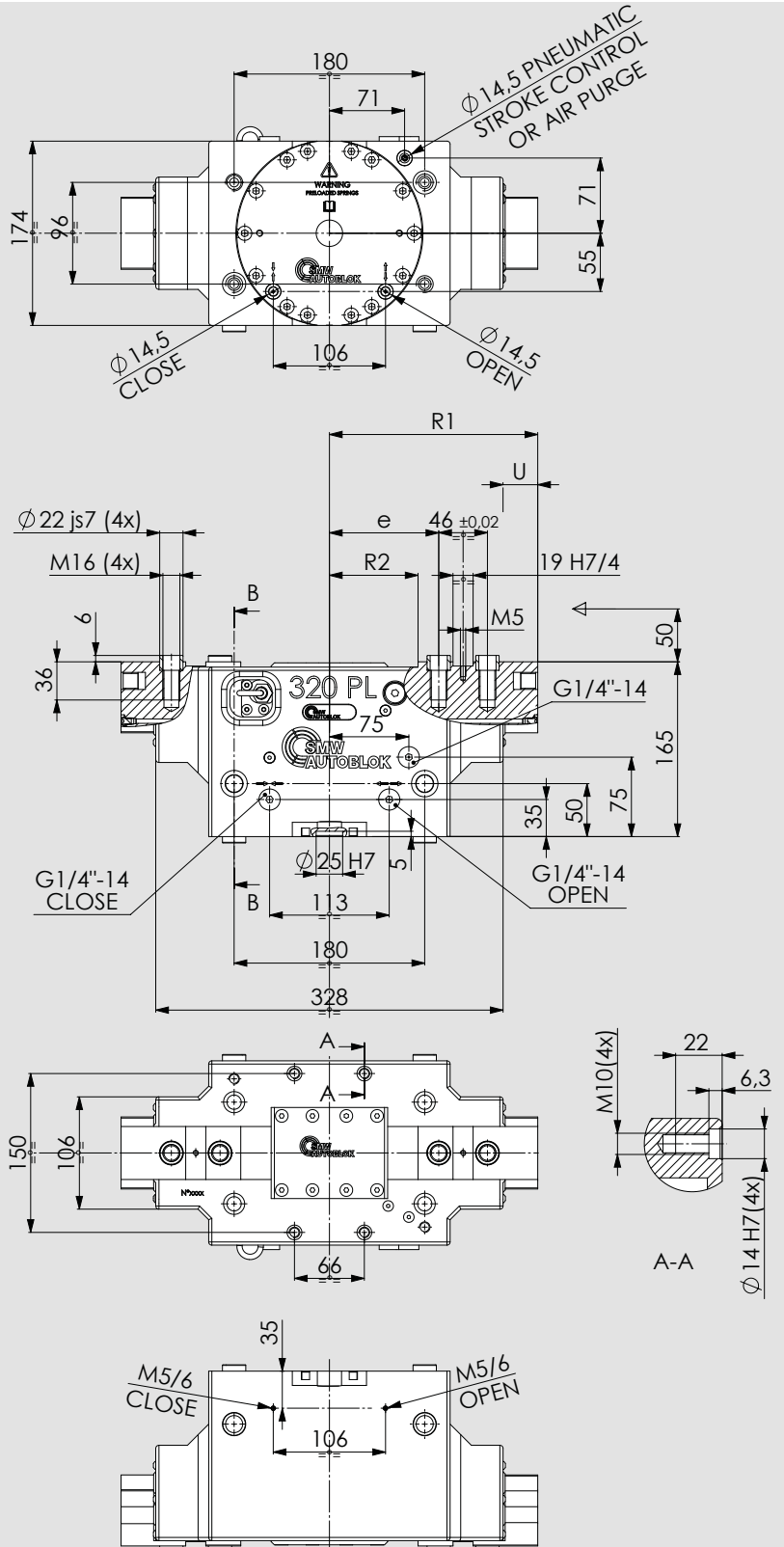
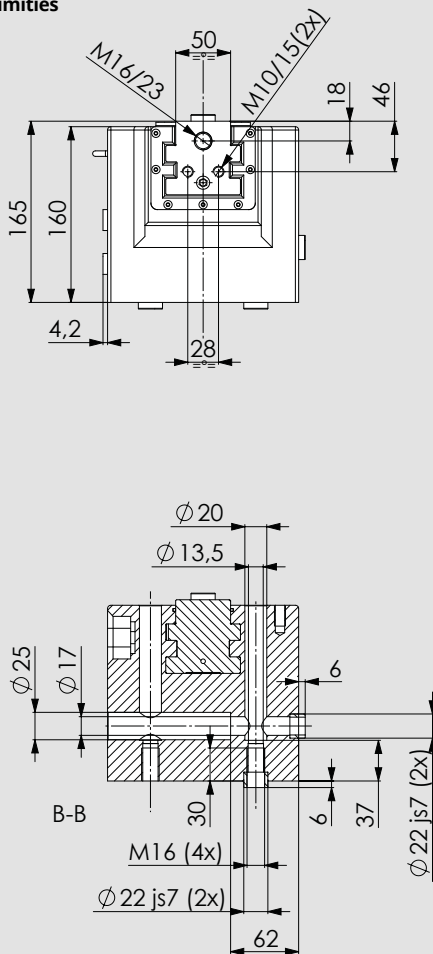

320

PL-RR

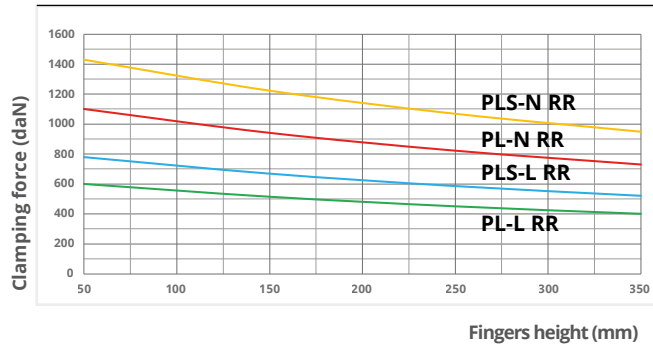

Clamping force calculated at **6 bar**.
 Max. recommended fingers height: **350 mm**
 Max. fingers weight: **12 Kg**
 For I.D. clamping consider **+3%** of the clamping force shown in the diagram.
 Use connecting screws **class 12.9**

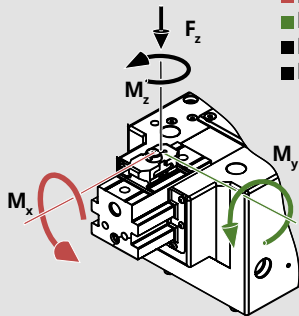

- M_x max. 400 Nm*
- M_y max. 400 Nm*
- M_z max. 280 Nm*
- F_z max. 8000 N*

* THE MOMENTS OF INERTIA INDICATED REFER TO ONE JAW AND CAN BE OCCUR SIMULTANEOUSLY. THE M_y MOMENT CAN BE ADDED TO THE CLAMPING FORCE MOMENT.



maximum allowed temperature using proximities is **60°C**

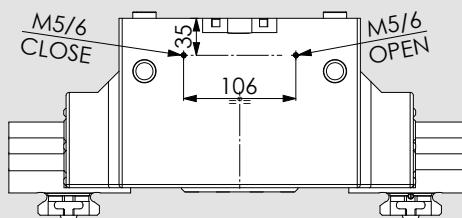
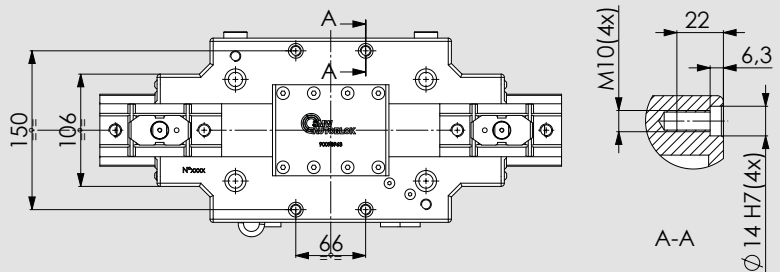
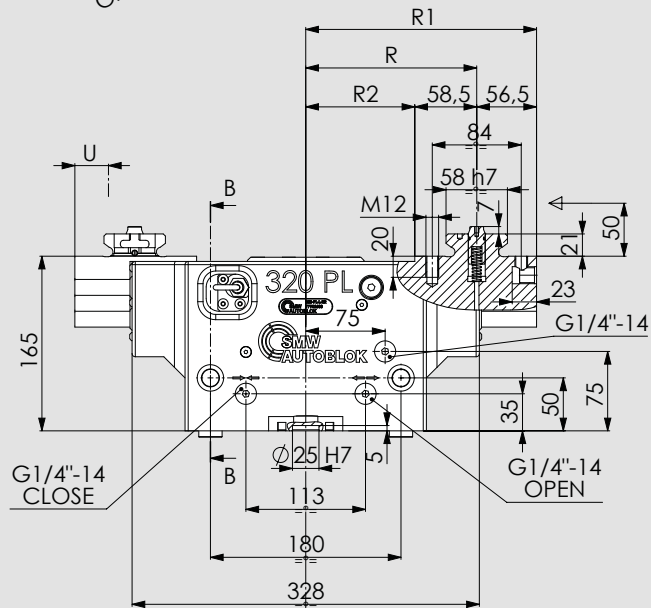
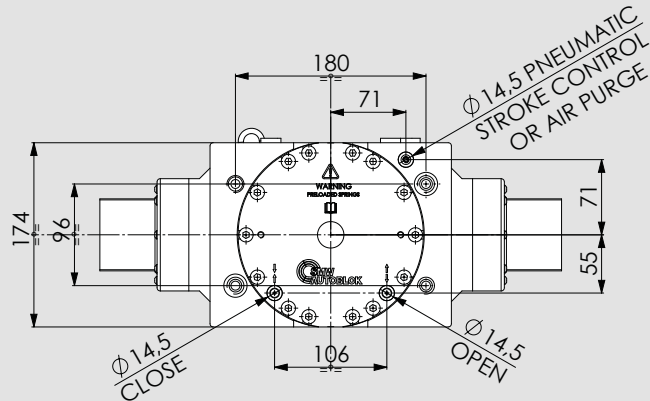
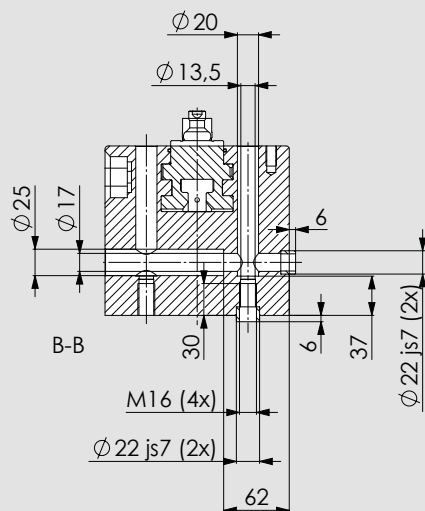
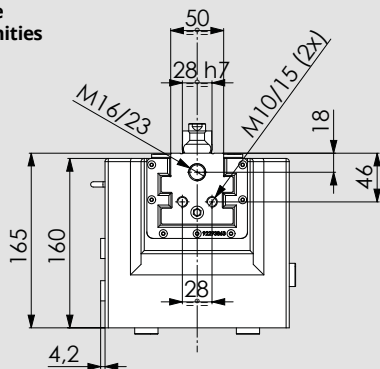

380

PL

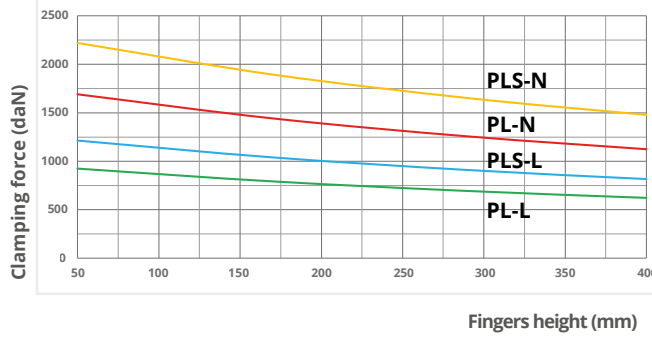

Clamping force calculated at **6 bar**.
 Max. recommended fingers height: **400 mm**
 Max. fingers weight: **17 Kg**
 For I.D. clamping consider **+4%** of the clamping force shown in the diagram.
 Use connecting screws **class 12.9**

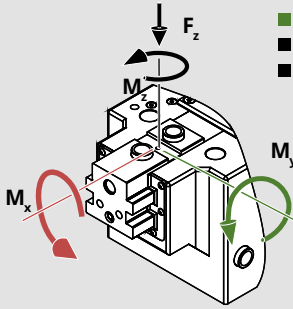

- M_x max. 560 Nm*
- M_y max. 560 Nm*
- M_z max. 370 Nm*
- F_z max. 10000 N*

* THE MOMENTS OF INERTIA INDICATED REFER TO ONE JAW AND CAN OCCUR SIMULTANEOUSLY. THE M_y MOMENT CAN BE ADDED TO THE CLAMPING FORCE MOMENT.



maximum allowed temperature using proximities is **60°C**

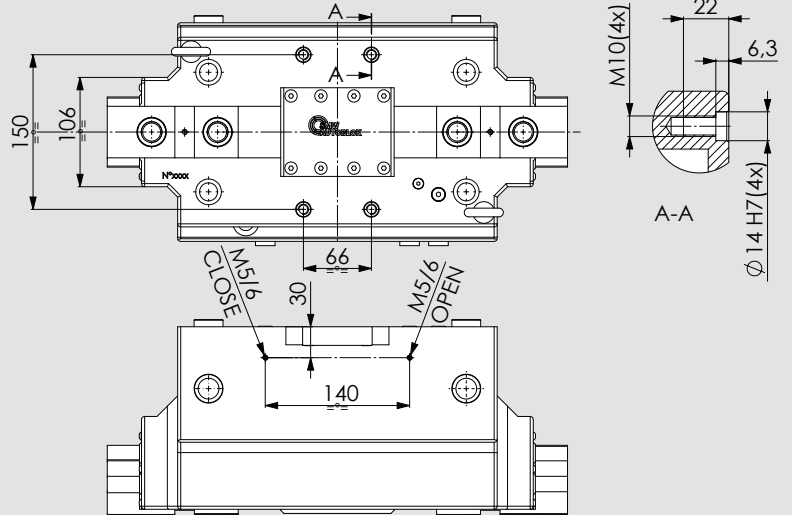
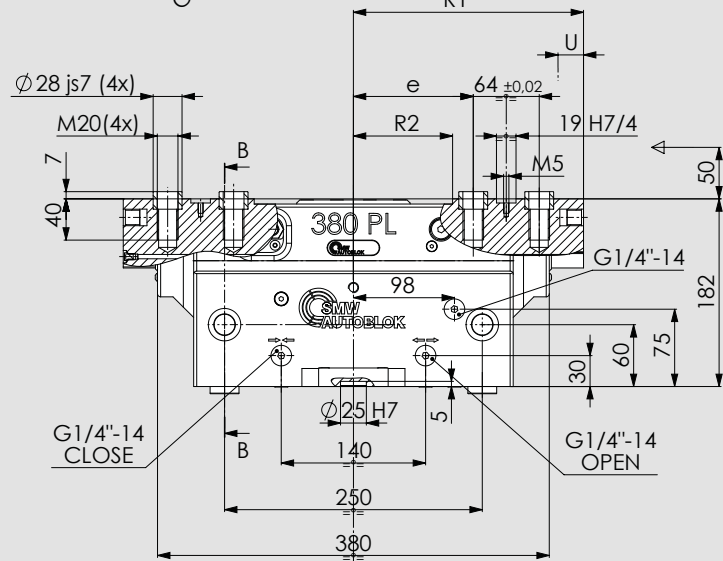
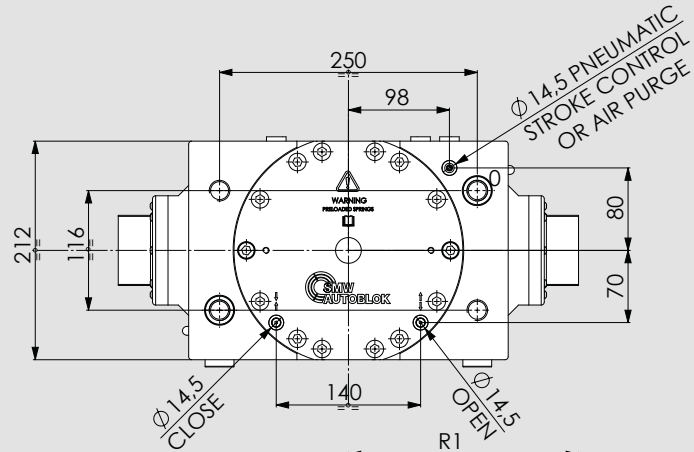
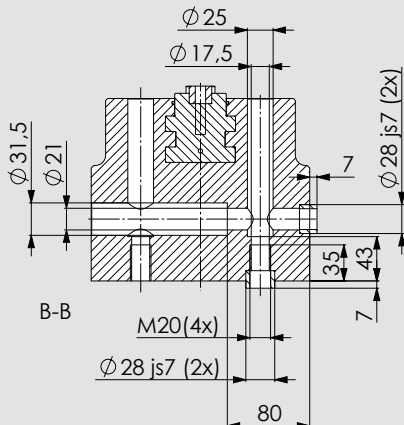
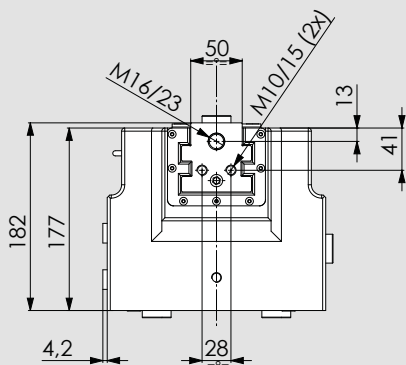

380

PL-RR

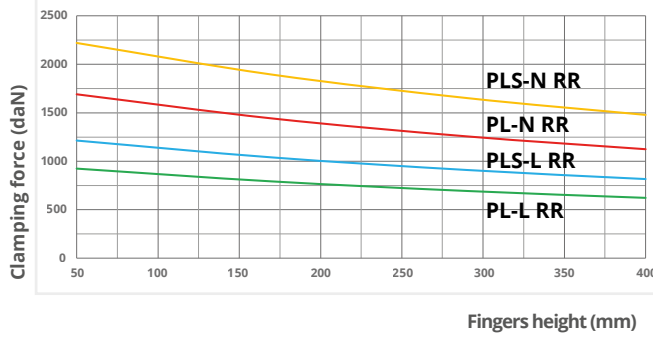

Clamping force calculated at **6 bar**.

Max. recommended fingers height: **400 mm**

Max. fingers weight: **17 Kg**

For I.D. clamping consider **+4%** of the clamping force shown in the diagram.

Use connecting screws **class 12.9**

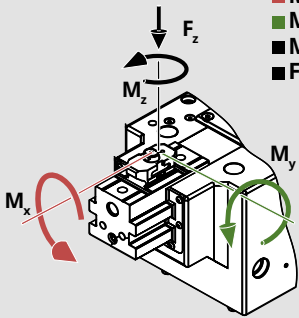

- M_x max. 560 Nm*
- M_y max. 560 Nm*
- M_z max. 370 Nm*
- F_z max. 10000 N*

* THE MOMENTS OF INERTIA INDICATED REFER TO ONE JAW AND CAN OCCUR SIMULTANEOUSLY. THE M_y MOMENT CAN BE ADDED TO THE CLAMPING FORCE MOMENT.



maximum allowed temperature using proximities is **60°C**

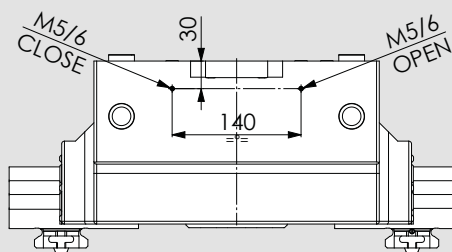
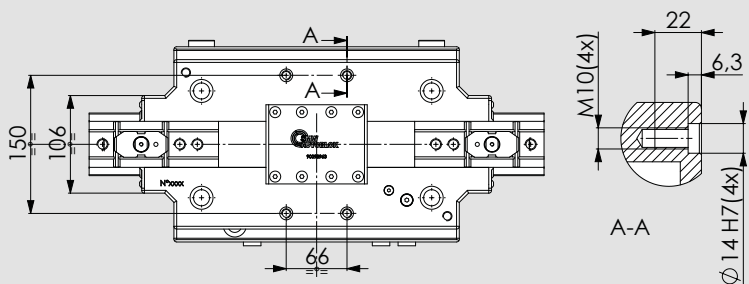
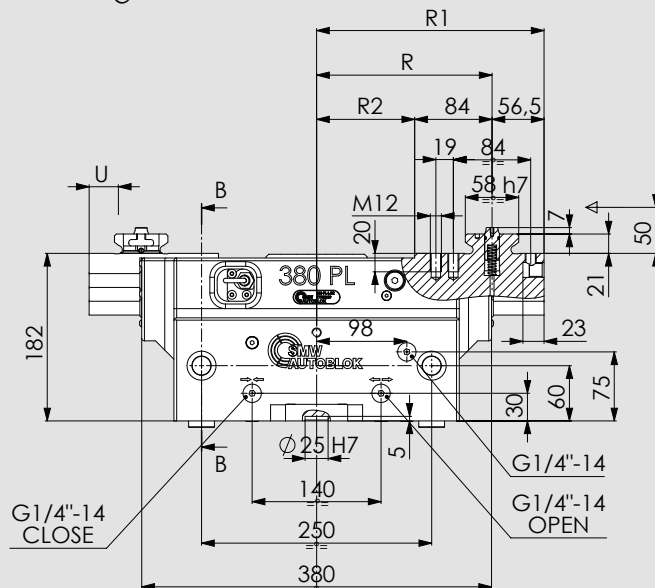
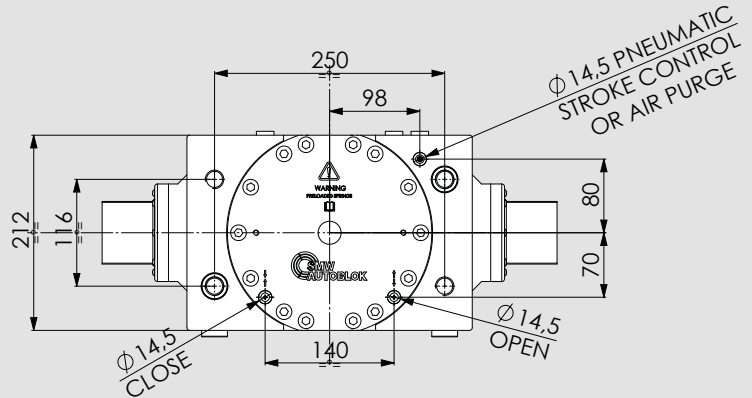
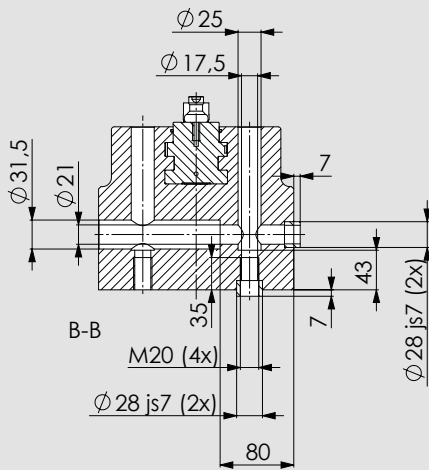
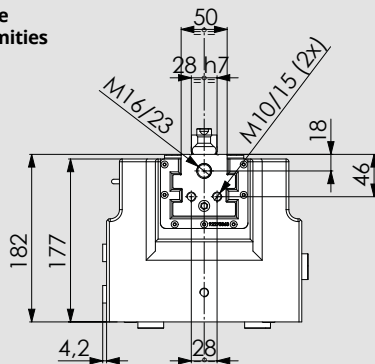

QUICK PALLET CHANGE for 320/380 sizes grippers

O.D. Clamping

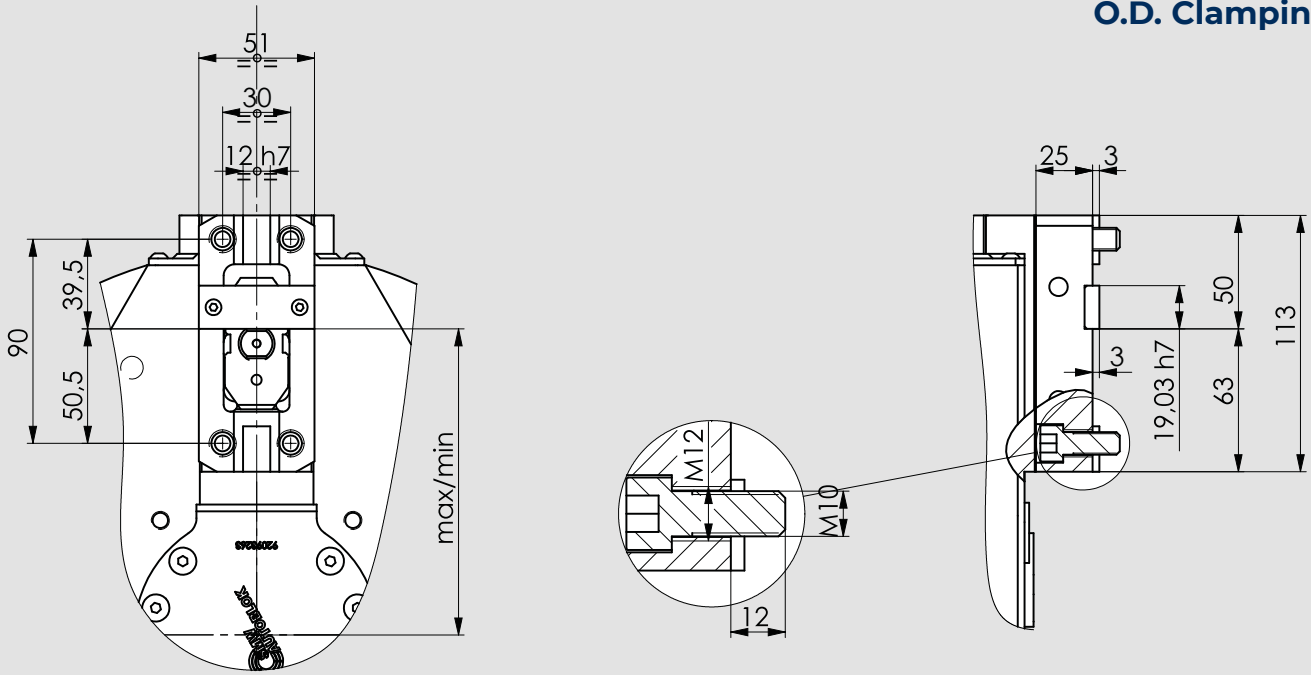

SMW-Autoblok Type	PALLET ID.N.(*)	Max / min OD clamping
PL-L 320 - RR	18762654	168 / 123
PL-N 320 - RR		146,5 / 123
PL-L 380 - RR		197 / 147
PL-N 380 - RR		173,2 / 147

(*) the Id.n. refers to 1 single pallet

I.D. Clamping

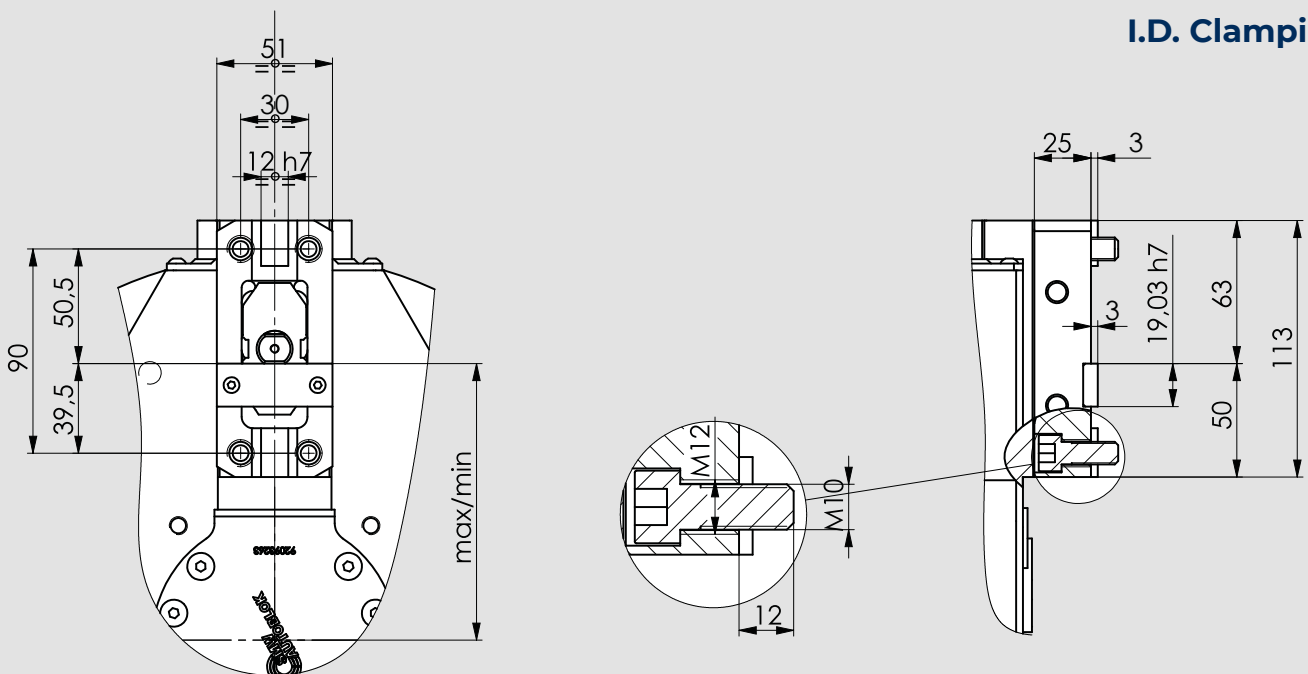

SMW-Autoblok Type	PALLET ID.N.(*)	Max / min ID clamping
PL-L 320 - RR	18762654	155 / 110
PL-N 320 - RR		133,5 / 110
PL-L 380 - RR		184 / 134
PL-N 380 - RR		160,2 / 134

(*) the Id.n. refers to 1 single pallet

PP PL GRIPPERS FINGERS for PALLET

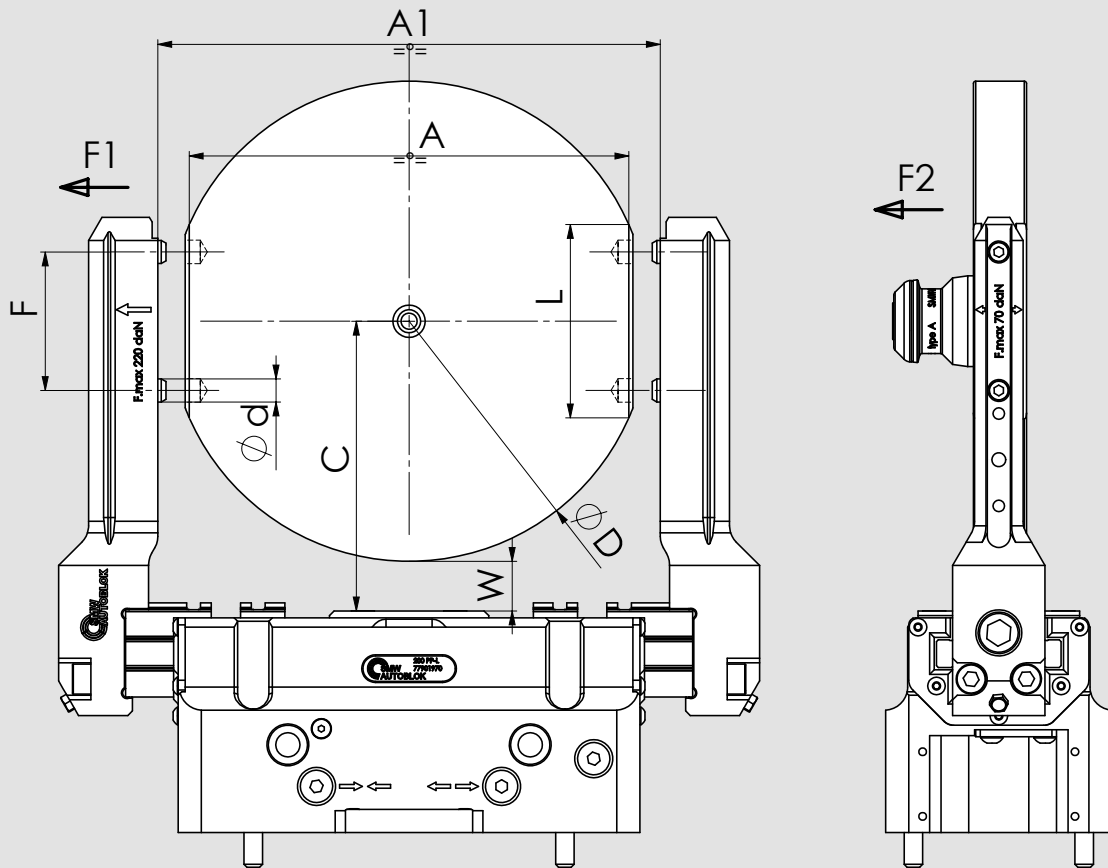

GRIPPER SMW-Autoblok Type	PALLET	FINGERS KIT ID.N.	A1 max GRIPPER OPEN	A (*) max/min PALLET	C	D (*) max/min PALLET DIAMETER	ød	F	L mm	W (with D max)	MAXIMUM CAPACITY ON PALLET	F1 max (for every finger)	F2 max (for every finger)
PP-L 125 PL-L 125	100	46204090	110	97/88	80	109/101	7	30	50	21,5	25 kg	100 daN	25 daN
	125	46204005	135	122/113	95	137/128	10	40	61	26,5	50 kg	105 daN	30 daN
	160	46204015	170	157/148	116	173/164	10	50	71	29,5	63 kg	115 daN	40 daN
PP-L 160 PL-L 160	125	46204010	135	122/113	81	137/128	10	40	61	12,5	63 kg	140 daN	40 daN
	160	46204020	170	157/148	106	173/164	10	50	71	19,5	80 kg	150 daN	50 daN
	200	46204030	210	197/188	126	215/206	10	60	85	18,5	80 kg	150 daN	50 daN
PP-L 200 PL-L 200	160	46204025	177,7	164/148	120	180/164	10	50	71	30	80 kg	210 daN	60 daN
	200	46204050	217,7	204/189	126	220/207	10	60	85	16	90 kg	220 daN	70 daN
	250	46204040	267,7	254/239	173	272/260	10	60	100	37	100 kg	220 daN	70 daN
PP-L 250 PL-L 250	200	46204055	244	230/189	162	245/207	10	60	85	39,5	100 kg	270 daN	80 daN
	250	46204045	294	280/239	200	297/260	10	60	100	51,5	100 kg	270 daN	80 daN
	315	46204080	359	345/304	242	365/325	10	60	112	59,5	125 kg	280 daN	90 daN

(*) to the A max and A min dimensions must correspond respectively the D max and D min dimension of the pallet.
To pallet with øD middle dimension to the maximum and the minimum must correspond a A proportional dimension.

FINGERS SET for PP-PL 125 grippers

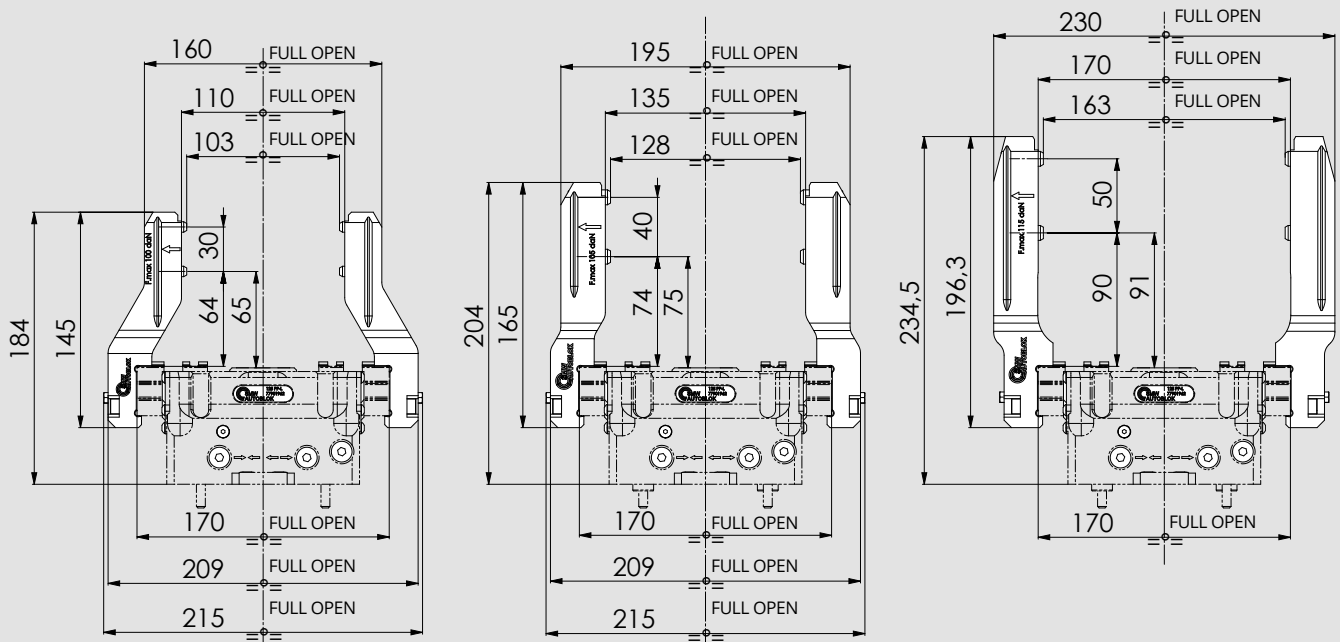

46204090

46204005

46204015

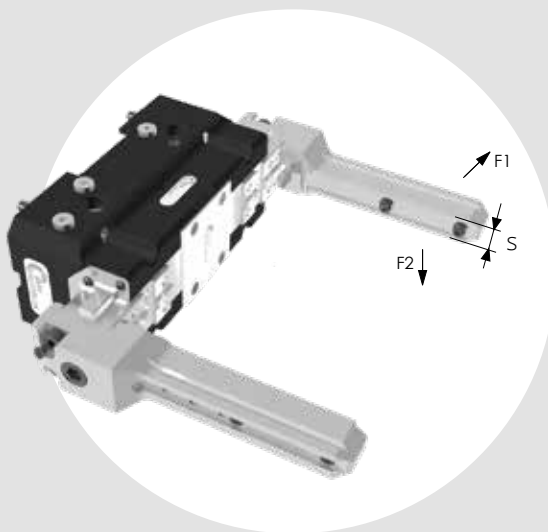
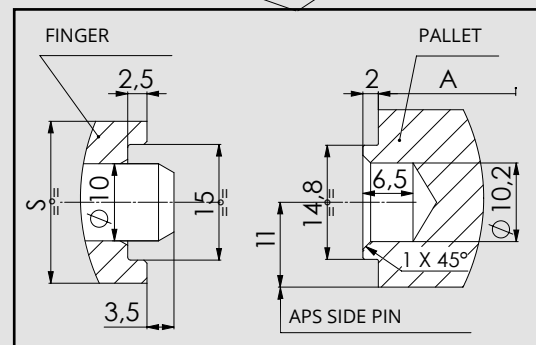
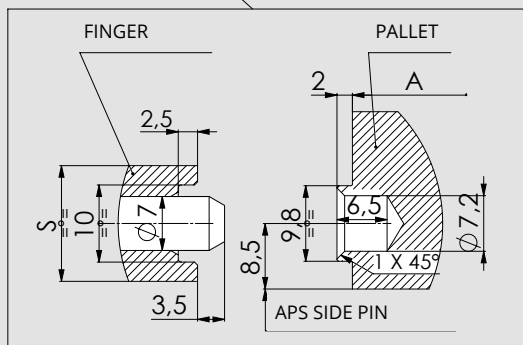

These fingers kit are available only for the PP and PL grippers (long stroke version)

FINGERS kit (the kit consisting in n.2 fingers plus mounting screws)	A (pallet)		S	F1max*	F2max*	Weight
	max	min				
46204090 2-FINGERS KIT PP-PL 125 GRIPPER / PALLET 100	97	88	15	100 daN	25 daN	1 Kg
46204005 2-FINGERS KIT PP-PL 125 GRIPPER / PALLET 125	122	113	21	105 daN	30 daN	1,5 Kg
46204015 2-FINGERS KIT PP-PL 125 GRIPPER / PALLET 160	157	148	21	115 daN	40 daN	1,9 Kg

* for every finger

FINGERS SET for PP-PL 160 grippers

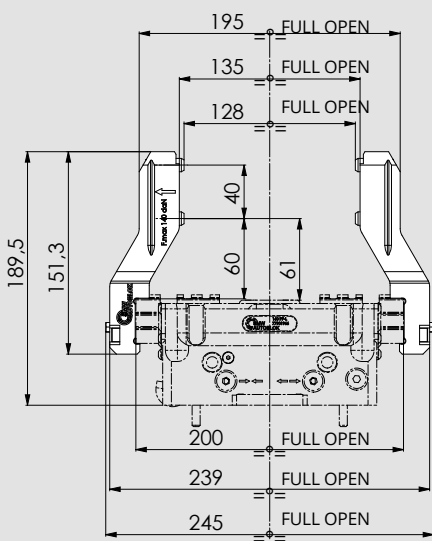

46204010

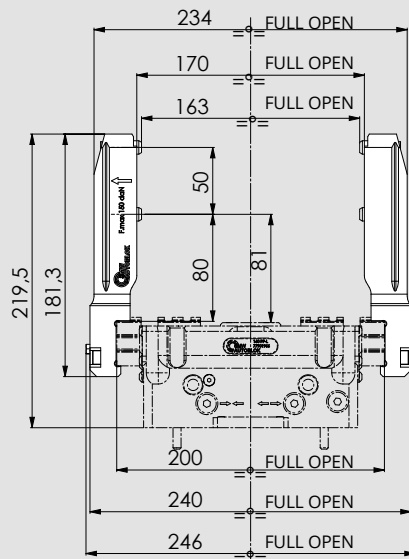

46204020

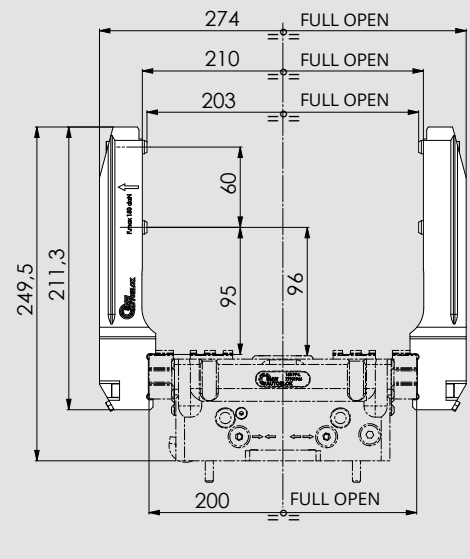

46204030

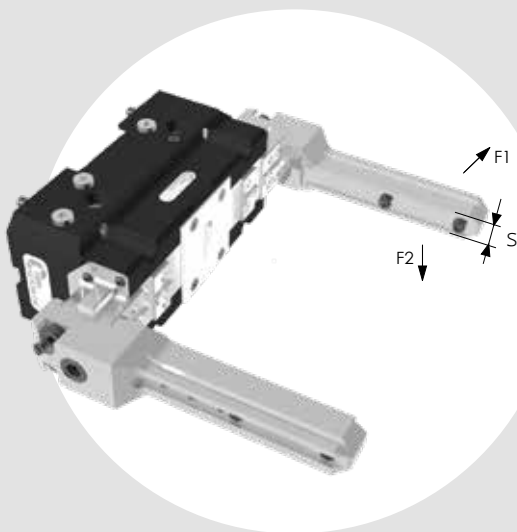
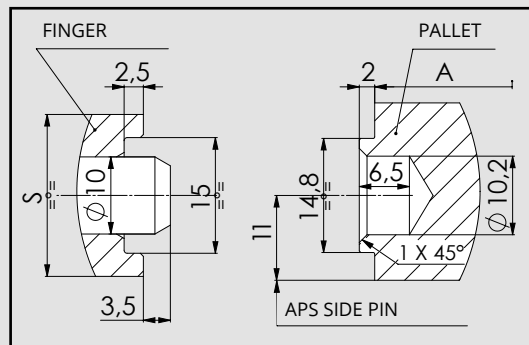

These fingers kit are available only for the PP and PL grippers (long stroke version)

	FINGERS kit (the kit consisting in n.2 fingers plus mounting screws)		S	F1max*	F2max*	Weight
	A (pallet) max	A (pallet) min				
46204010 2-FINGERS KIT PP-PL 160 GRIPPER / PALLET 125	122	113	21	140 daN	40 daN	1,4 Kg
46204020 2-FINGERS KIT PP-PL 160 GRIPPER / PALLET 160	157	148	21	150 daN	50 daN	1,6 Kg
46204030 2-FINGERS KIT PP-PL 160 GRIPPER / PALLET 200	197	188	21	150 daN	50 daN	2,3 Kg

* for every finger

FINGERS SET for PP-PL 200 grippers

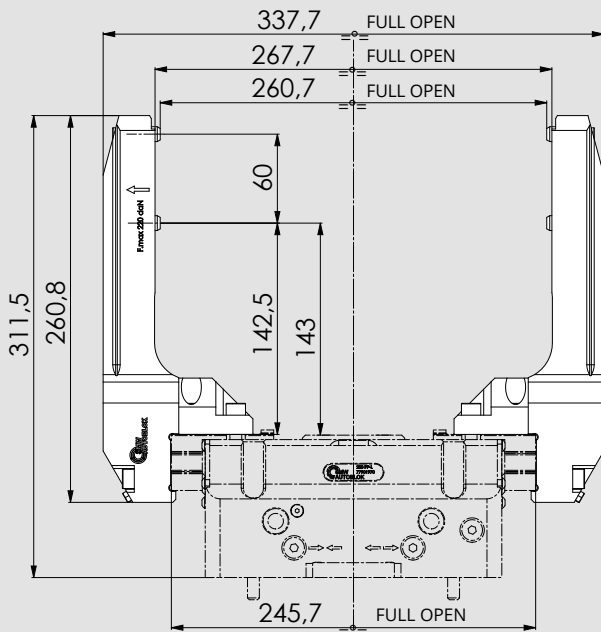

46204040

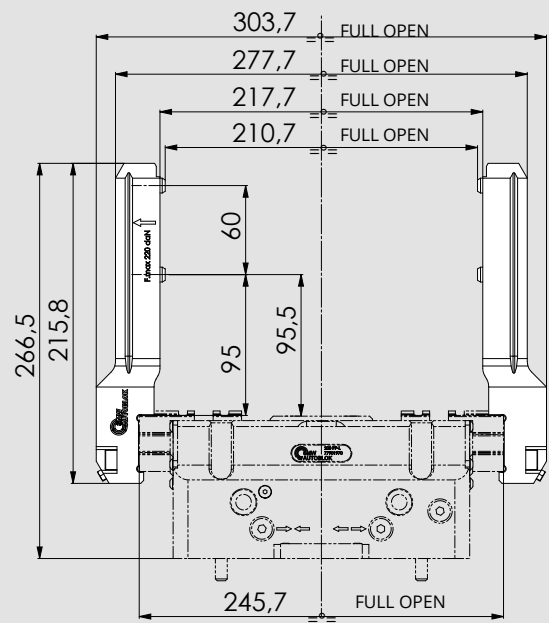

46204050

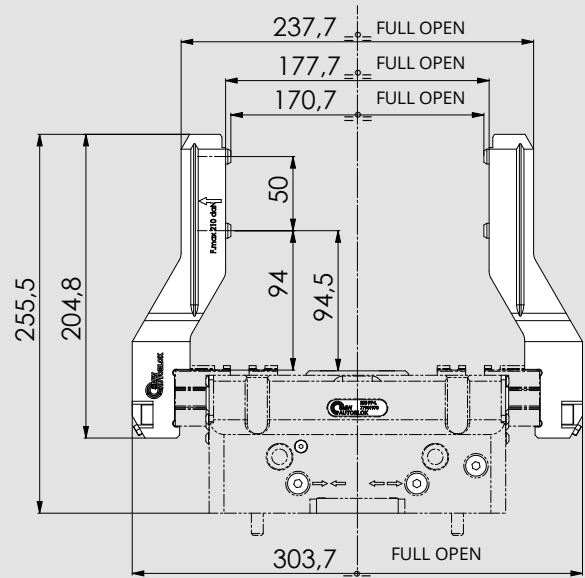
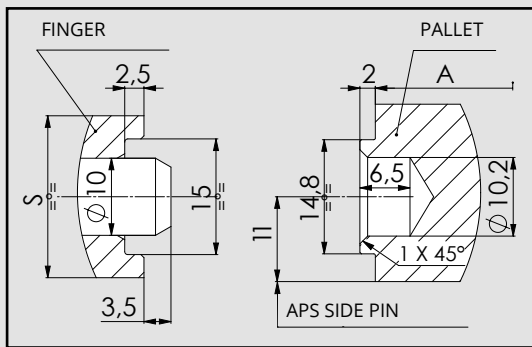

46204025

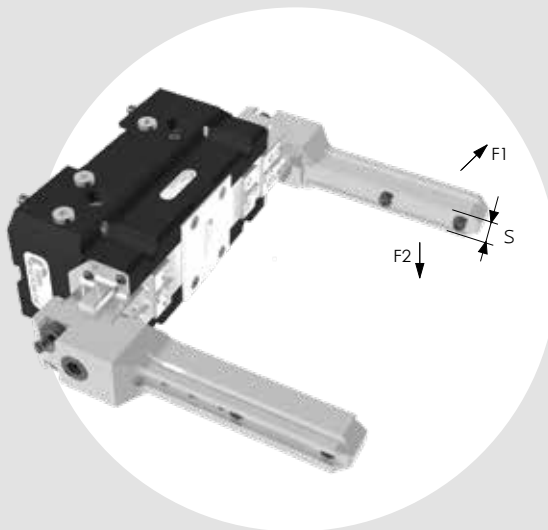

These fingers kit are available only for the the PP and PL grippers (long stroke version)

	FINGERS kit (the kit consisting in n.2 fingers with mounting screws)		S	F1max*	F2max*	Weight
	A (pallet) max	A (pallet) min				
46204025 2-FINGERS KIT PP-PL 200 GRIPPER / PALLET 160	164	148	21	210 daN	60 daN	2,6 Kg
46204040 2-FINGERS KIT PP-PL 200 GRIPPER / PALLET 250	254	239	21	220 daN	70 daN	4,6 Kg
46204050 2-FINGERS KIT PP-PL 200 GRIPPER / PALLET 200	204	189	21	220 daN	70 daN	2,6 Kg

* for every finger

FINGERS SET for PP-PL 250 grippers

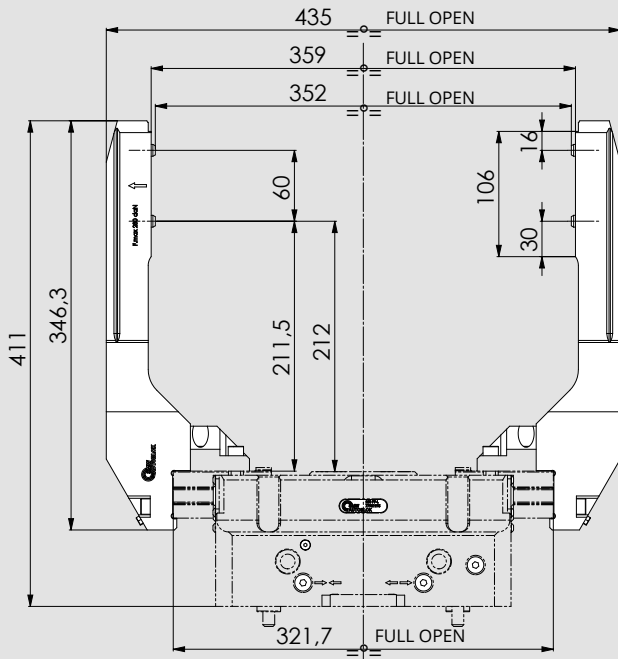

46204080

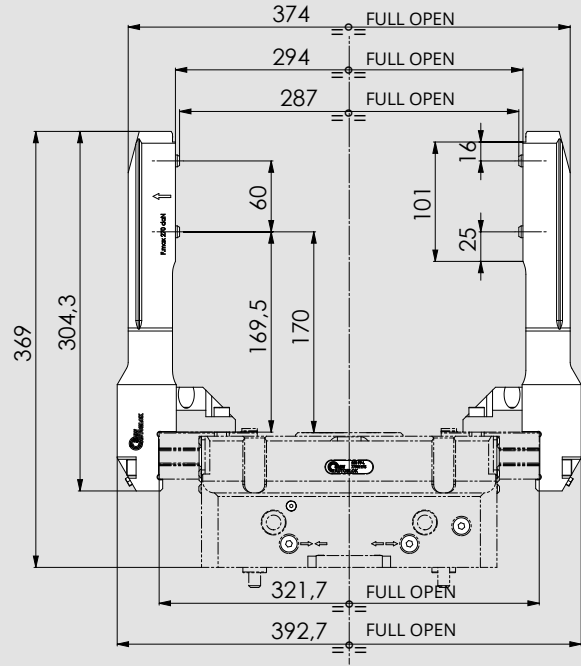

46204045

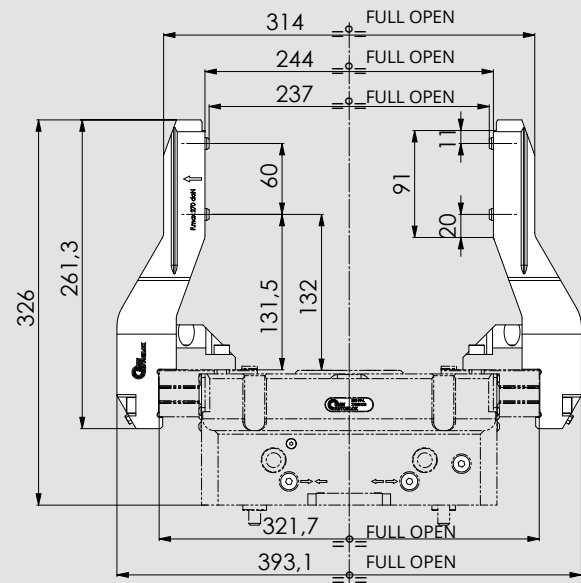
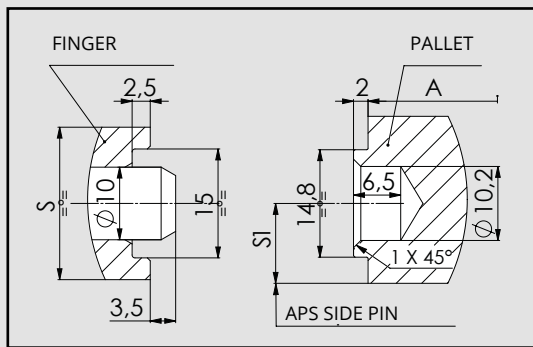

46204055

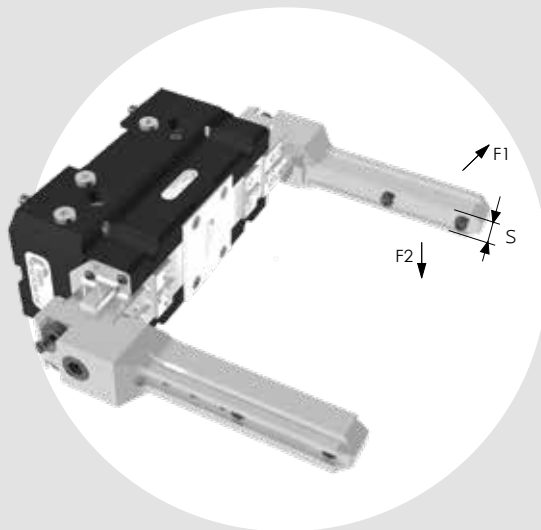

These fingers kit are available only for the PP and PL grippers (long stroke version)

Drawings and data are subject to change by SMW-Autoblok.

	FINGERS kit (the kit consisting in n.2 fingers plus mounting screws)		S	S1	F1max*	F2max*	Weight
	A (pallet) max	min					
46204055 2-FINGERS KIT PP-PL 250 GRIPPER / PALLET 200	230	189	21	11	270 daN	80 daN	5,4 Kg
46204045 2-FINGERS KIT PP-PL 250 GRIPPER / PALLET 250	280	239	21	11	270 daN	80 daN	6 Kg
46204080 2-FINGERS KIT PP-PL 250 GRIPPER / PALLET 315	345	304	25	13.5	280 daN	90 daN	8 Kg

* for every finger

PP-L 160 GRIPPERS FINGERS SET

quick fingers change RR on PT-RR Twin Vise

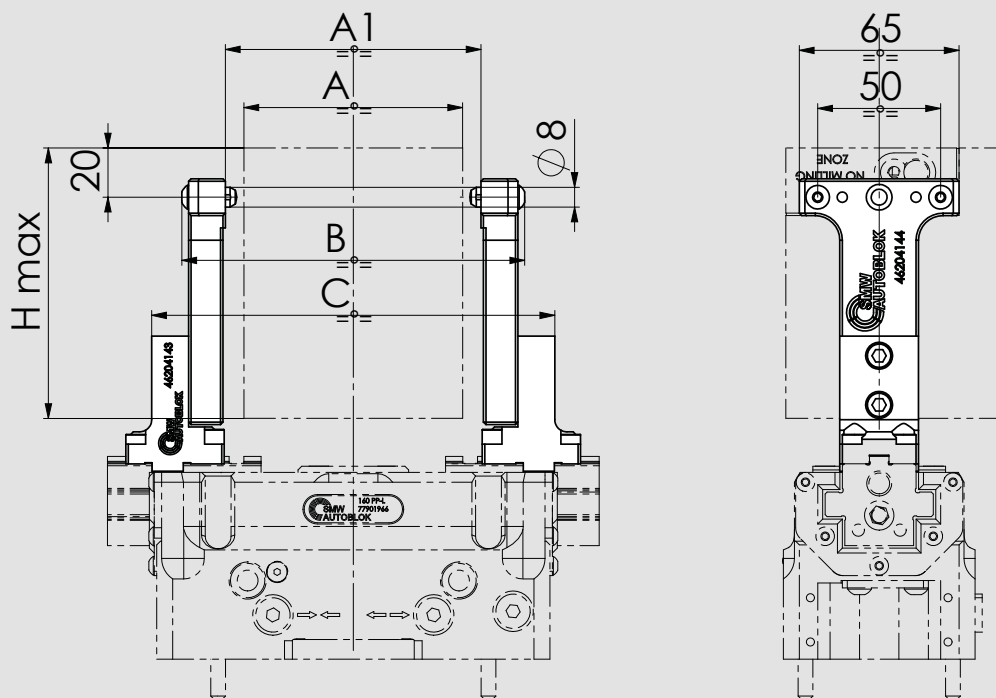

FINGERS SET Id.N.	GRIPPERS Type	A1 max open vise	A min/max clamping range	B max	C max	H max	TWIN VISE PT-RR Type	Base Id.n.	Extension Id.n.
46204130	PP-L 160 PL-L 160	104	81/91	140	162	110	160 PT	46204143	46204144
46204131		123	100/110	159	187	140	200 PT	46204133	46204134
46204132		153	130/140	189	217	140	250 PT	46204135	46204134

PP-L 125 AND 160 GRIPPERS FINGERS SET

quick fingers change RR on chuck APL-RR and NTL-RR

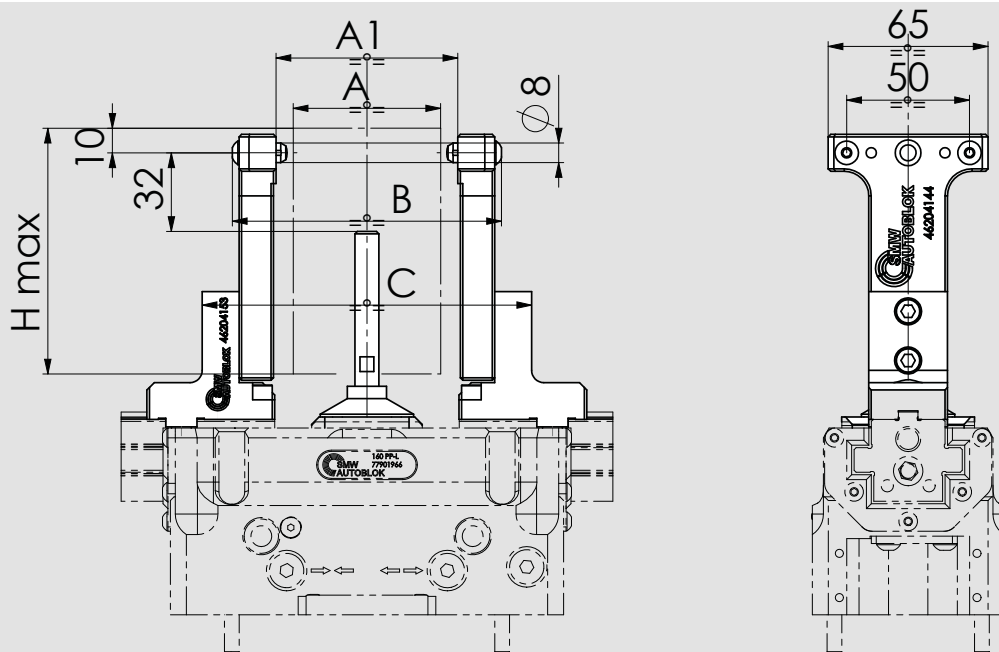

FINGERS SET Id.N.	GRIPPERS Type	A1 max open vise	A min/max clamping range	B max	C max	H max	APL/NTL-RR CHUCK SMW-Autoblok Type	Base Id.n.	Extension Id.n.
46204140	PP-L 125	69	46/56	105	129	100	210-260-315 APL-RR	46204142	46204144
46204141	PL-L 125	74	51/61	110	135	100	260-315-400 APL-RR	46204143	46204144
46204150	PP-L 160	69	46/56	105	129	100	210-260-315 APL-RR	46204152	46204144
46204151	PL-L 160	74	51/61	110	135	100	260-315-400 APL-RR	46204153	46204144

BRACKET PALLET KIT 400x400 AND 400x200 with PP-N - PL-N 200 gripper

MAXIMUM PALLET WEIGHT: 150KG

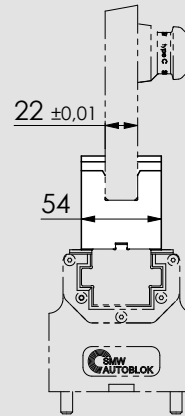
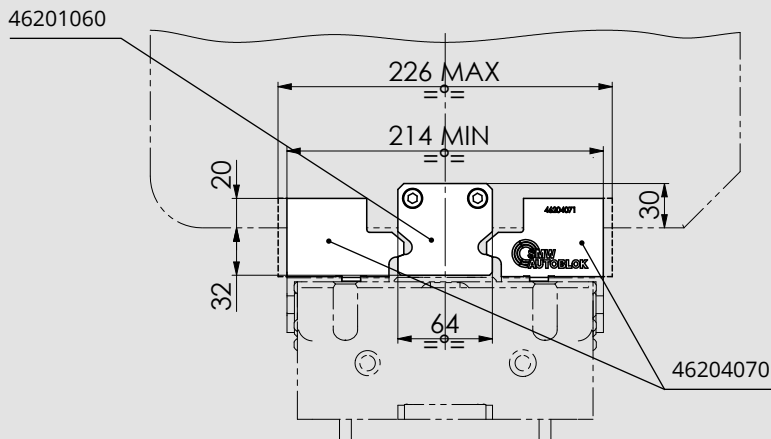

PALLET HOLES FOR BRACKET MOUNTING

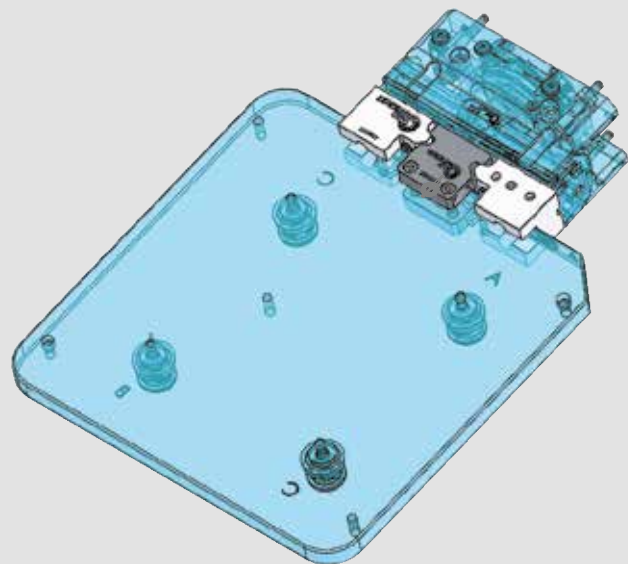
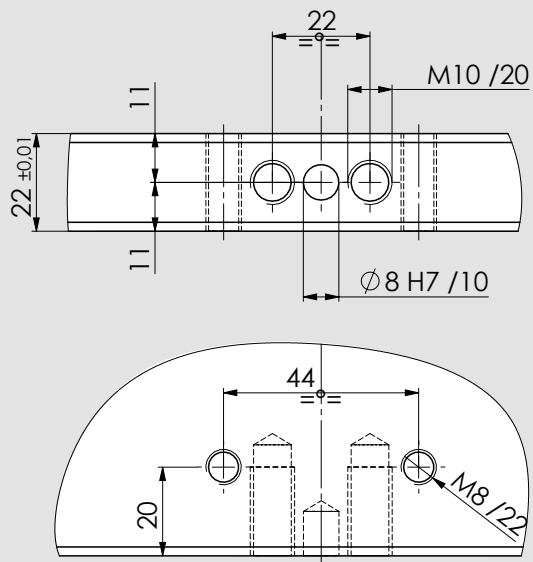

Id.No.	Weight
46201060 BRACKET KIT PP-N 200 GRIPPER / PALLET Q400	1,2 Kg
46204070 2 FINGERS KIT PP-N 200 GRIPPER / PALLET Q400	2,4 Kg
77901870 PP-N 200 GRIPPER (STEEL)	11 Kg
77901871 PL-N 200 GRIPPER (ALUMINIUM)	6,5 Kg

2PXS

2 jaws self-centering grippers Ø64-80-100

ALUMINIUM

Pneumatics

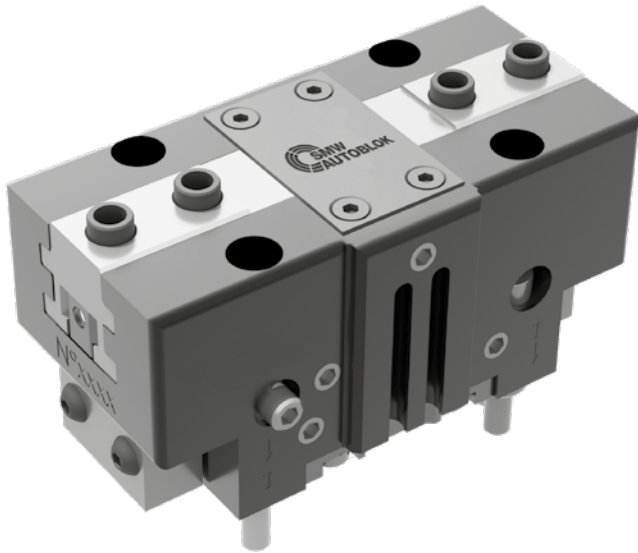

Technical features

- Aluminium body to contain the gripper weight
- Functional parts heat-treated for high precision and long life
- Jaws with calibrated bushings
- Protection class IP40
- Highest rigidity and Repeatability: 0,01 mm
- Prepared for Air purge

OPTIONAL

- Inductive/Analogic stroke control sensor ON/OFF or linear
- Magnetic stroke control sensor ON/OFF or linear

Applications/Customer benefits

- Compact and light design
- OD and/or ID clamping (also with springs)
- Side or rear feeding and fixing
- Interchangeable with most existing universal grippers

Standard equipment

Grippers without fingers and without sensors.
All screws for the double mounting, all centering bushings and all interface OR included.

SMW-Autoblok TYPE	Id. No.	Clamping force (daN) at 6 bar	Spring force min. (daN)	U (mm) jaw stroke	Air volume (cm ³)	Pressure (bar) min./max.	Opening/ Closing time (s) at 6 bar	Weight (Kg)	Workpiece weight recommended (Kg)	e (mm) min./max.	R1 (mm) min./max.	R2 (mm) min./max.
2PXS-N 64	77901856	63	----	3	8	2/8	0,03/0,03	0,3	3,0	14,25/17,25	36/39	10/13
2PXS-NSE 64	77902056	93	30	3	17	4/6,5	0,04/0,02	0,38	3,0	14,25/17,25	36/39	10/13
2PXS-NSI 64	77901156	101	30	3	18,5	4/6,5	0,02/0,04	0,38	3,0	14,25/17,25	36/39	10/13
2PXS-L 64	77901956	30	----	6	8	2/8	0,03/0,03	0,3	1,5	14,25/20,25	33/39	10/16
2PXS-LSE 64	77902156	44	14	6	17	4/6,5	0,04/0,02	0,38	1,5	14,25/20,25	33/39	10/16
2PXS-LSI 64	77901256	48	14	6	18,5	4/6,5	0,02/0,04	0,38	1,5	14,25/20,25	33/39	10/16
2PXS-N 80	77901858	97	----	4	17	2/8	0,04/0,04	0,55	5,0	18,75/22,5	44/48	13,5/17,5
2PXS-NSE 80	77902058	129	32	4	31	4/6,5	0,05/0,03	0,65	5,0	18,75/22,5	44/48	13,5/17,5
2PXS-NSI 80	77901158	141	32	4	33	4/6,5	0,03/0,05	0,65	5,0	18,75/22,5	44/48	13,5/17,5
2PXS-L 80	77901958	46	----	8	17	2/8	0,04/0,04	0,55	2,5	18,75/26,5	40/48	13,5/21,5
2PXS-LSE 80	77902158	61	15	8	31	4/6,5	0,05/0,03	0,65	2,5	18,75/26,5	40/48	13,5/21,5
2PXS-LSI 80	77901258	67	15	8	33	4/6,5	0,03/0,05	0,65	2,5	18,75/26,5	40/48	13,5/21,5
2PXS-N 100	77901860	155	----	5	33,5	2/8	0,07/0,07	0,93	8,0	23,5/28,5	55/60	17,5/22,5
2PXS-NSE 100	77902060	229	74	5	67	4/6,5	0,1/0,05	1,2	8,0	23,5/28,5	55/60	17,5/22,5
2PXS-NSI 100	77901160	245	74	5	71	4/6,5	0,05/0,1	1,2	8,0	23,5/28,5	55/60	17,5/22,5
2PXS-L 100	77901960	73	----	10	33,5	2/8	0,07/0,07	0,93	4,0	23,5/33,5	50/60	17,5/27,5
2PXS-LSE 100	77902160	108	35	10	67	4/6,5	0,1/0,05	1,2	4,0	23,5/33,5	50/60	17,5/27,5
2PXS-LSI 100	77901260	116	35	10	71	4/6,5	0,05/0,1	1,2	4,0	23,5/33,5	50/60	17,5/27,5

Note: 2PXS-N: Normal stroke 2PXS-L: Long stroke 2PXS-NSE: Normal stroke OD 2PXS-NSI: Normal stroke ID
2PXS-LSE: Long stroke OD 2PXS-LSI: Long stroke ID

64

2PXS

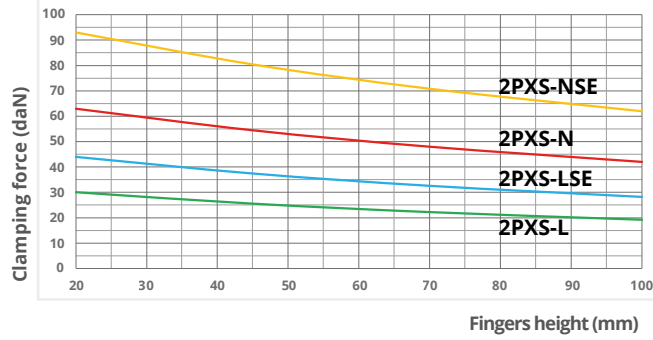

Clamping force calculated at **6 bar**.
 Max. recommended fingers height: **100 mm**
 Max. fingers weight: **0,4 Kg**
 For I.D. clamping consider **+10%** of the clamping force shown in the diagram.
 Use connecting screws **class 12.9**

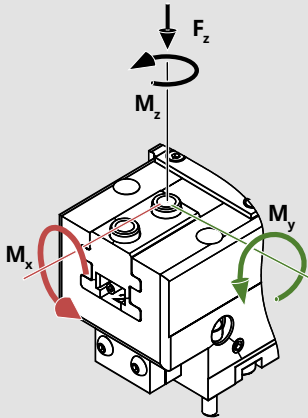

- M_x max. 45 Nm*
- M_y max. 60 Nm*
- M_z max. 40 Nm*
- F_z max. 1200 N*

* THE MOMENTS OF INERTIA INDICATED REFER TO ONE JAW AND CAN BE OCCUR SIMULTANEOUSLY. THE M_y MOMENT CAN BE ADDED TO THE CLAMPING FORCE MOMENT.

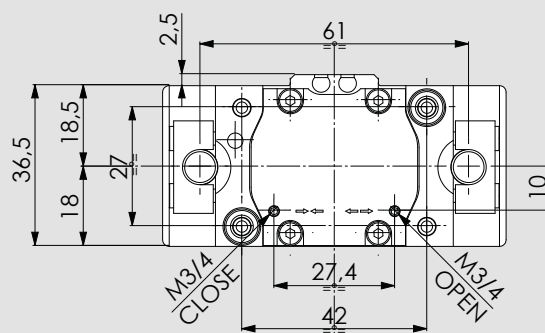

max allowed temperature using proximities is **60°C**

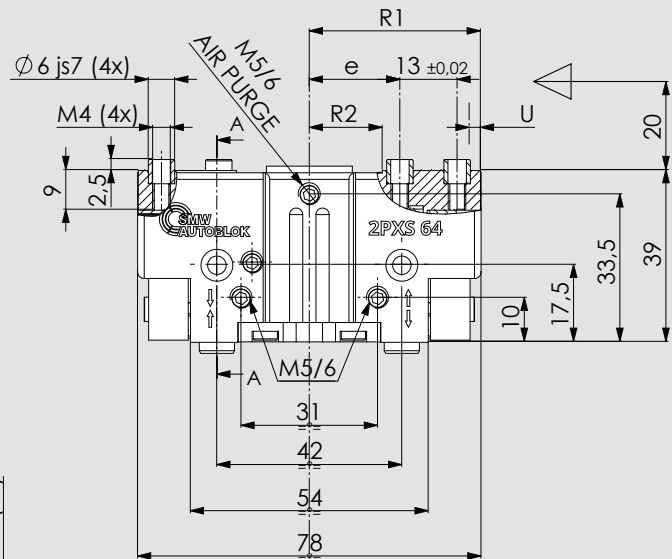
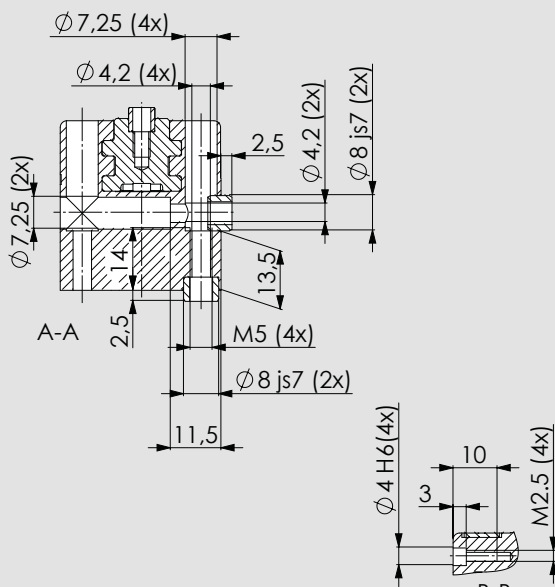

2 PXS-LSE 2PXS-LSI 2PXS-NSE 2PXS-NSI

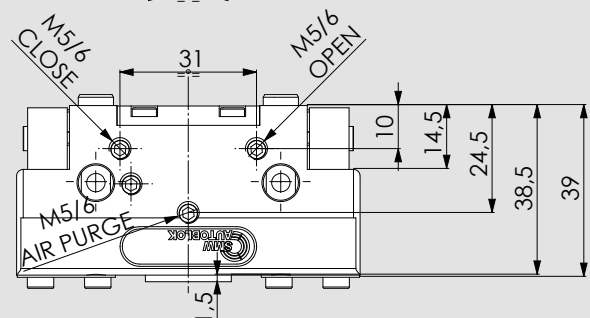
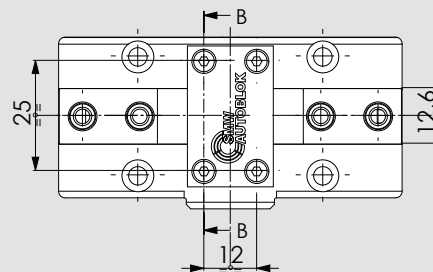
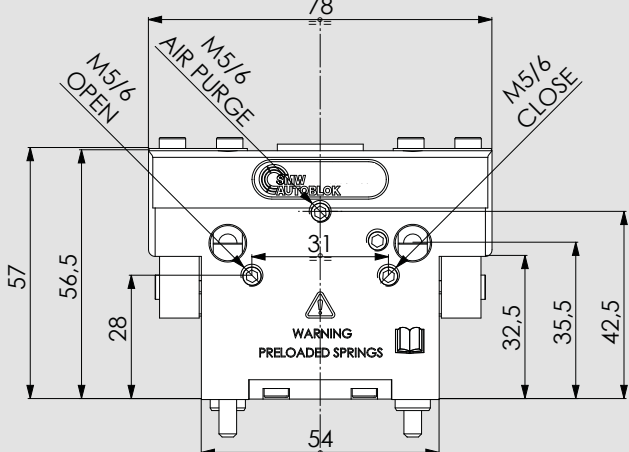

80

2PXS

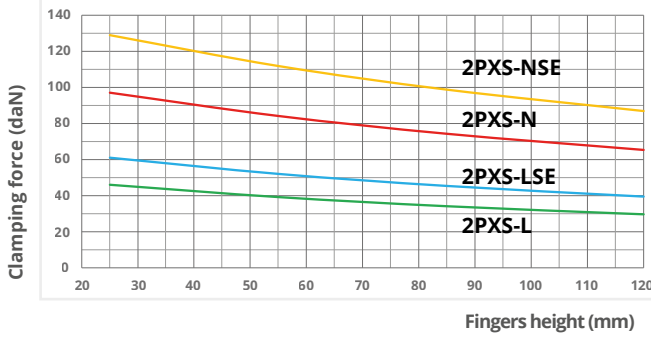

Clamping force calculated at **6 bar**.
 Max. recommended fingers height: **120 mm**
 Max. fingers weight: **0,7 Kg**
 For I.D. clamping consider **+10%** of the clamping force shown in the diagram.
 Use connecting screws **class 12.9**

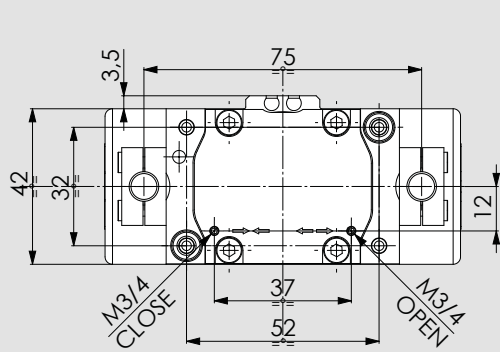
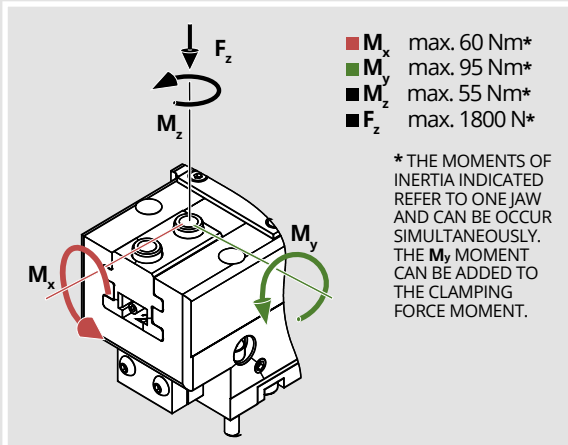

+10°C +70°C

 max allowed temperature using proximities is 60°C

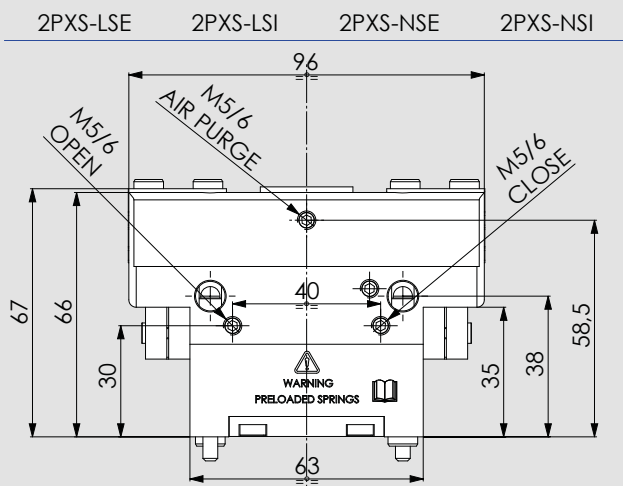
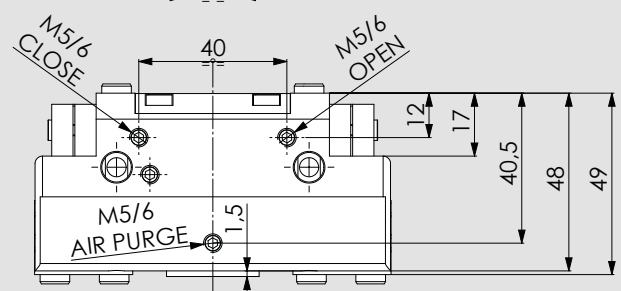
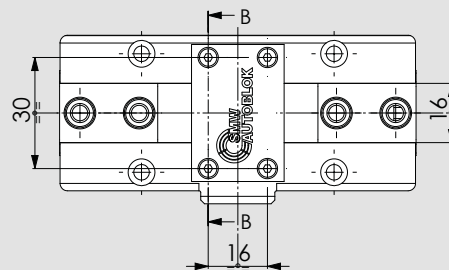
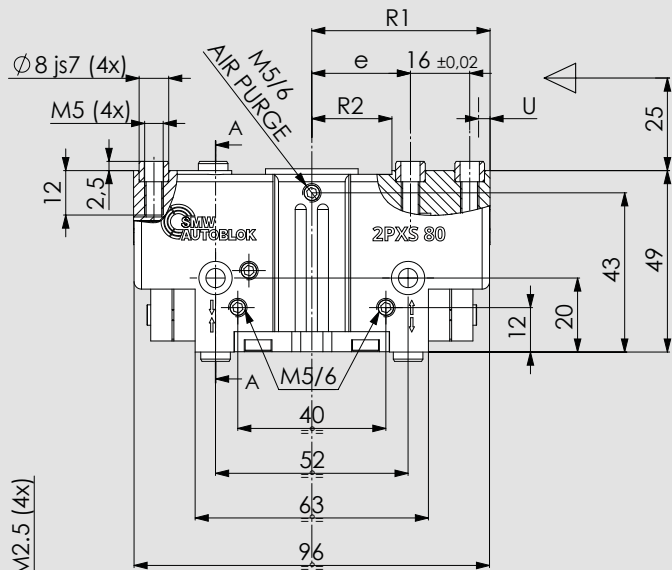
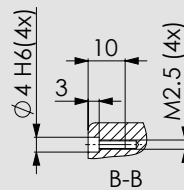
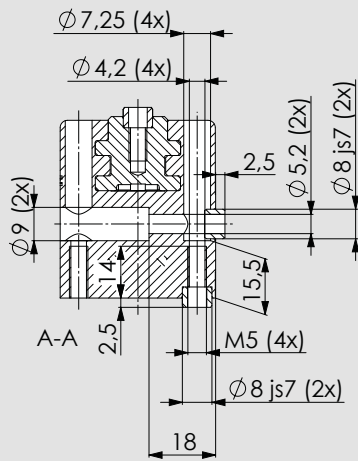

100

2PXS

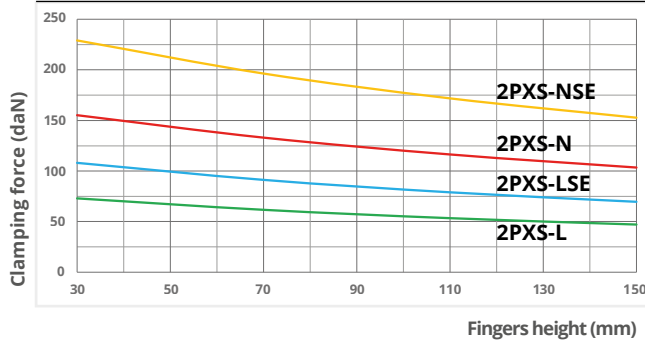

Clamping force calculated at **6 bar**.

Max. recommended fingers height: **150 mm**

Max. fingers weight: **1,2 Kg**

For I.D. clamping consider **+7%** of the clamping force shown in the diagram.

Use connecting screws **class 12.9**

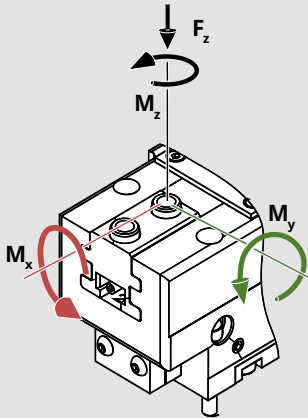

- M_x max. 90 Nm*
- M_y max. 110 Nm*
- M_z max. 75 Nm*
- F_z max. 2350 N*

* THE MOMENTS OF INERTIA INDICATED REFER TO ONE JAW AND CAN BE OCCUR SIMULTANEOUSLY. THE M_y MOMENT CAN BE ADDED TO THE CLAMPING FORCE MOMENT.

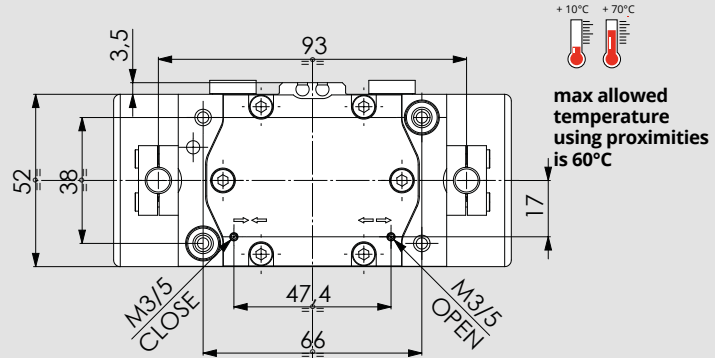

max allowed temperature using proximities is **60°C**

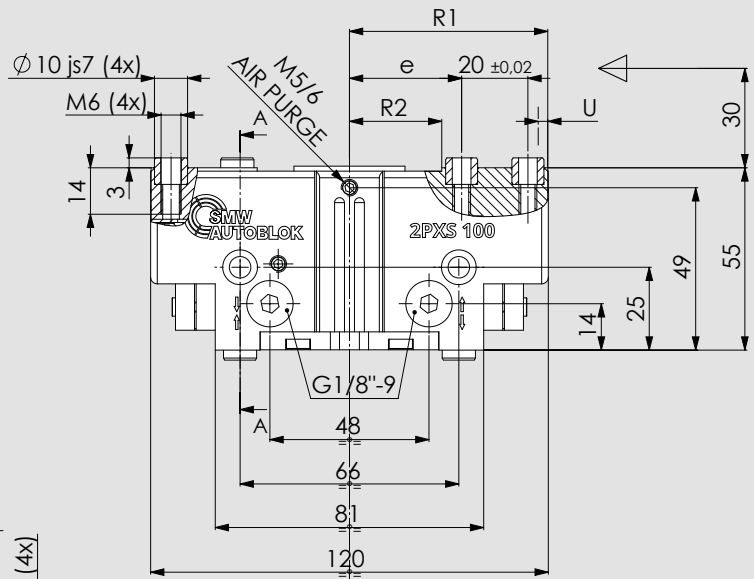
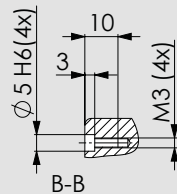
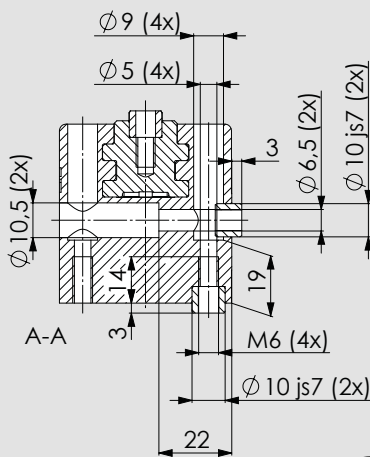

2PXS-LSE 2PXS-LSI 2PXS-NSE 2PXS-NSI

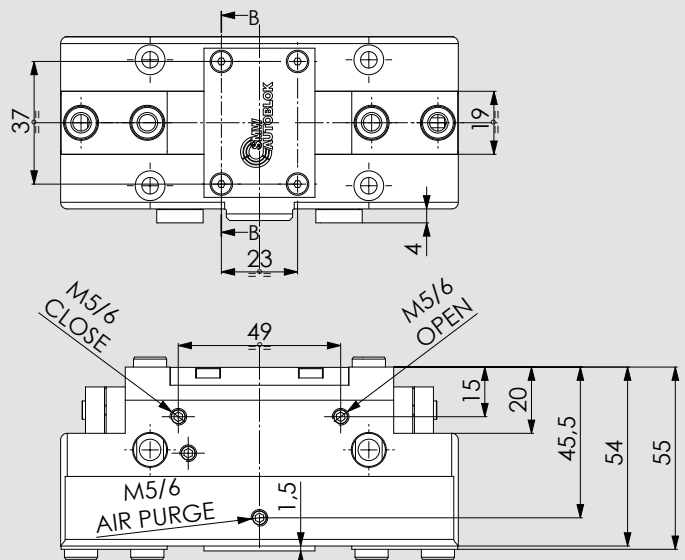
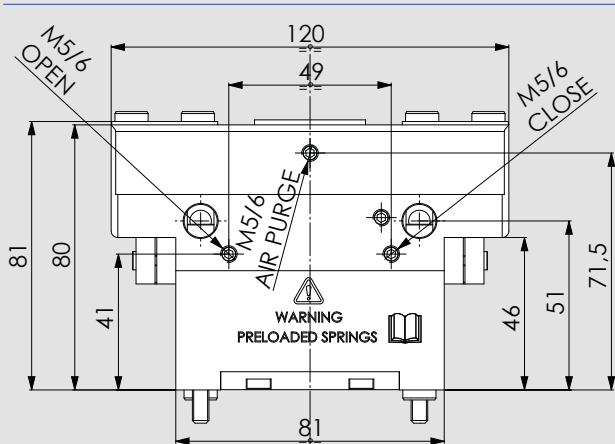

2PXM

2 jaws self-centering grippers Ø125-160-200

ALUMINIUM

Pneumatics - Protected



Technical features

- Aluminium body to contain the gripper weight
- Functional parts heat-treated for high precision and long life
- Jaws with calibrated bushings
- Protection class IP64
- Highest rigidity and Repeatability: 0,02 mm
- Prepared for Air purge

OPTIONAL

- Inductive/Analogic stroke control sensor ON/OFF or linear
- Magnetic stroke control sensor ON/OFF or linear

Applications/Customer benefits

- Compact and light design
- OD and/or ID clamping (also with springs)
- Side or rear feeding
- Interchangeable with most existing universal grippers

Standard equipment

Grippers without fingers and without sensors.
All screws for the double mounting, all centering bushings and all interface OR included.

SMW-Autoblok TYPE	Id. No.	Clamping force (daN) at 6 bar	Spring force min. (daN)	U (mm) jaw stroke	Air volume (cm³)	Pressure (bar) min./max.	Opening/ Closing time (s) at 6 bar	Weight (Kg)	Workpiece weight recommended (Kg)	e (mm) min./max.	R1 (mm) min./max.	R2 (mm) min./max.
2PXM-N 125	77901864	280	-----	6	79	2/8	0,1/0,1	1,6	14,0	30,5/36,5	71,5/77,5	23,5/29,5
2PXM-NSE 125	77902064	390	110	6	151	4/6,5	0,12/0,08	2	14,0	30,5/36,5	71,5/77,5	23,5/29,5
2PXM-NSI 125	77901164	407	110	6	157	4/6,5	0,08/0,12	2	14,0	30,5/36,5	71,5/77,5	23,5/29,5
2PXM-L 125	77901964	132	-----	13	79	2/8	0,1/0,1	1,6	7,0	30,5/43,5	64,5/77,5	23,5/36,5
2PXM-LSE 125	77902164	184	52	13	151	4/6,5	0,12/0,08	2	7,0	30,5/43,5	64,5/77,5	23,5/36,5
2PXM-LSI 125	77901264	192	52	13	157	4/6,5	0,08/0,12	2	7,0	30,5/43,5	64,5/77,5	23,5/36,5
2PXM-N 160	77901868	456	-----	8	161	2/8	0,14/0,14	2,9	23,0	38,5/46,5	90/98	29,5/37,5
2PXM-NSE 160	77902068	651	195	8	318	4/6,5	0,22/0,11	3,7	23,0	38,5/46,5	90/98	29,5/37,5
2PXM-NSI 160	77901168	685	195	8	330,5	4/6,5	0,11/0,22	3,7	23,0	38,5/46,5	90/98	29,5/37,5
2PXM-L 160	77901968	215	-----	16	161	2/8	0,14/0,14	2,9	11,0	38,5/54,5	82/98	29,5/45,5
2PXM-LSE 160	77902168	307	92	16	318	4/6,5	0,22/0,11	3,7	11,0	38,5/54,5	82/98	29,5/45,5
2PXM-LSI 160	77901268	324	92	16	330,5	4/6,5	0,11/0,22	3,7	11,0	38,5/54,5	82/98	29,5/45,5
2PXM-N 200	77901872	556	-----	14	373	2/8	0,3/0,3	5,8	28,0	38/52	105/119	28,5/42,5
2PXM-NSE 200	77902072	756	200	14	733	4/6,5	0,5/0,3	7,3	28,0	38/52	105/119	28,5/42,5
2PXM-NSI 200	77901172	790	200	14	758	4/6,5	0,3/0,5	7,3	28,0	38/52	105/119	28,5/42,5
2PXM-L 200	77901972	370	-----	25	373	2/8	0,3/0,3	5,8	18,5	38/63	94/119	28,5/53,5
2PXM-LSE 200	77902172	502	132	25	733	4/6,5	0,5/0,3	7,3	18,5	38/63	94/119	28,5/53,5
2PXM-LSI 200	77901272	526	132	25	758	4/6,5	0,3/0,5	7,3	18,5	38/63	94/119	28,5/53,5

Note: 2PXM-N: Normal stroke 2PXM-L: Long stroke 2PXM-NSE: Normal stroke OD 2PXM-NSI: Normal stroke ID
2PXM-LSE: Long stroke OD 2PXM-LSI: Long stroke ID

125

2PXM

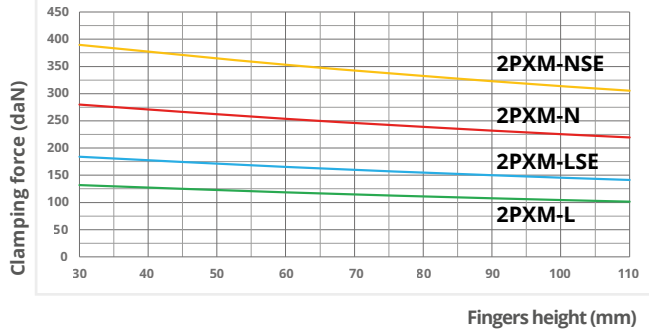

Clamping force calculated at **6 bar**.
 Max. recommended fingers height: **110 mm**
 Max. fingers weight: **2,3 Kg**
 For I.D. clamping consider **+5%** of the clamping force shown in the diagram.
 Use connecting screws **class 12.9**

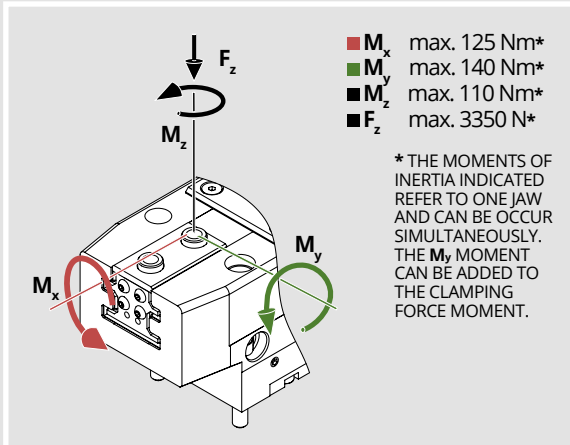

max allowed temperature using proximities is **60°C**

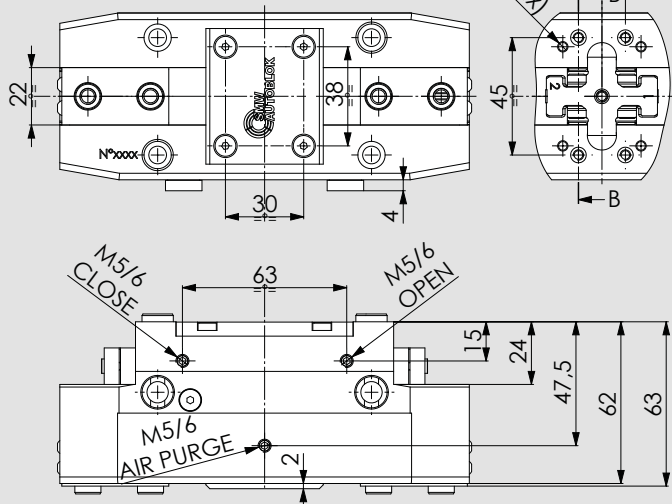
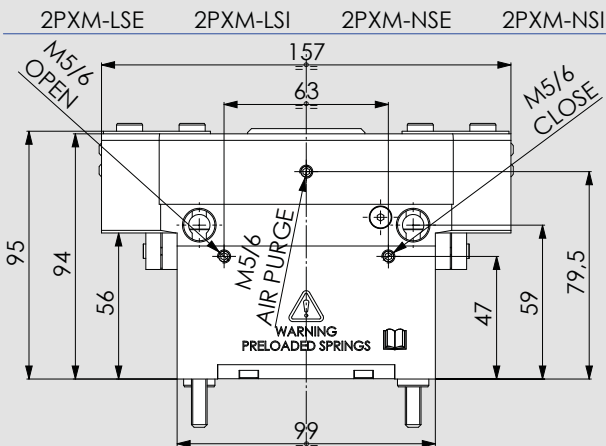
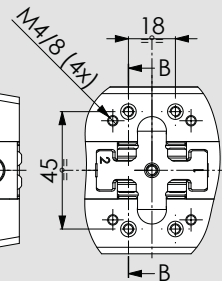
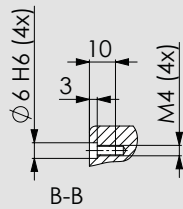
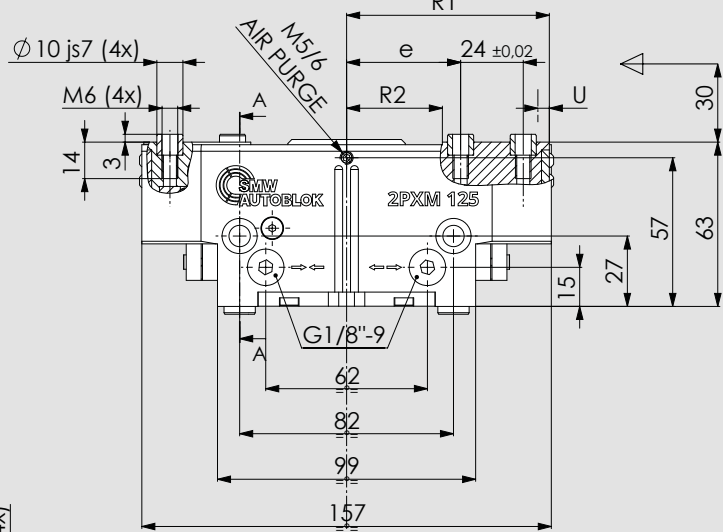
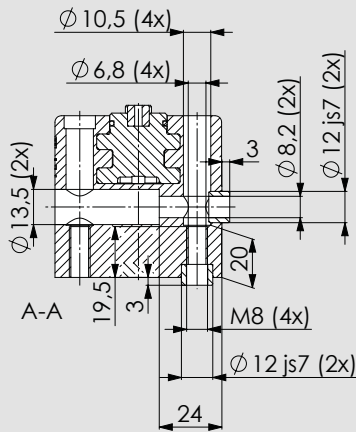
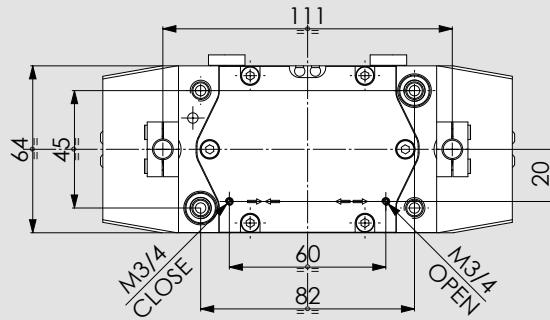

Drawings and data are subject to change by SMW-Autoblok.

160

2PXM

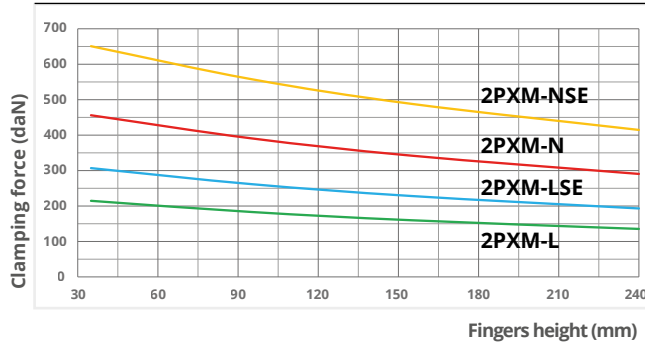

Clamping force calculated at **6 bar**.
 Max. recommended fingers height: **240 mm**
 Max. fingers weight: **3,7 Kg**
 For I.D. clamping consider **+5%** of the clamping force shown in the diagram.
 Use connecting screws **class 12.9**

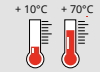
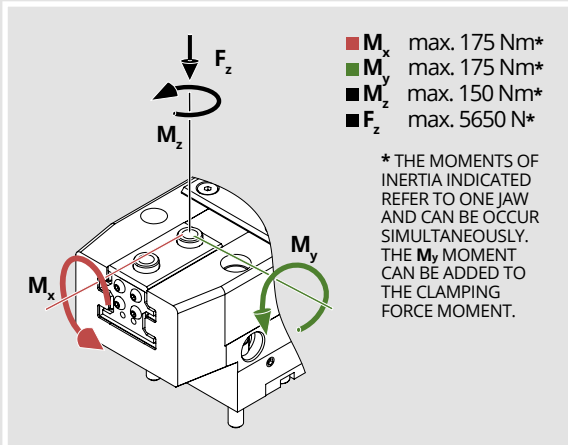

max allowed temperature using proximities is **60°C**

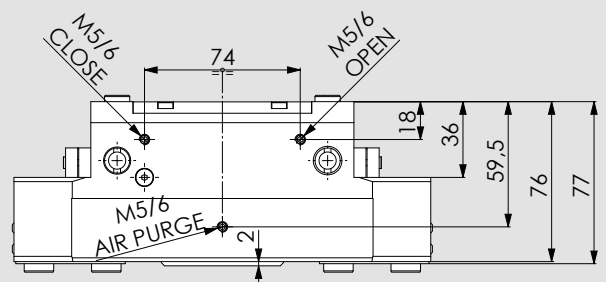
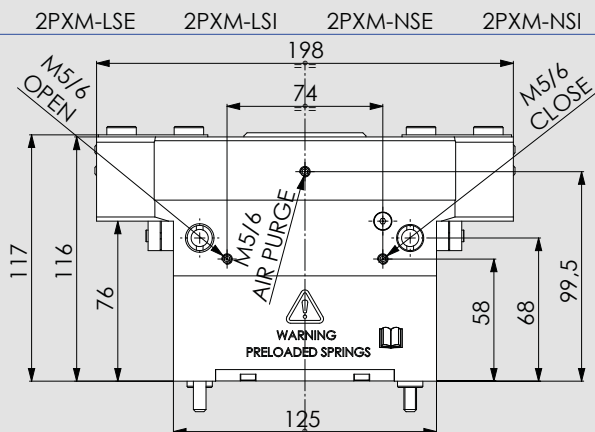
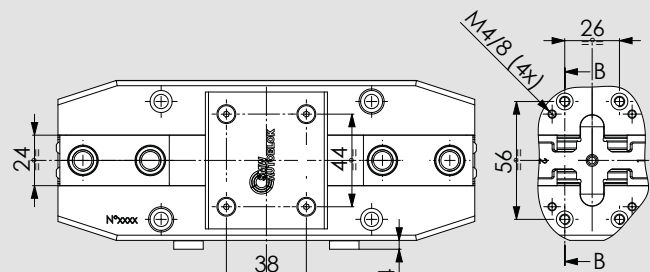
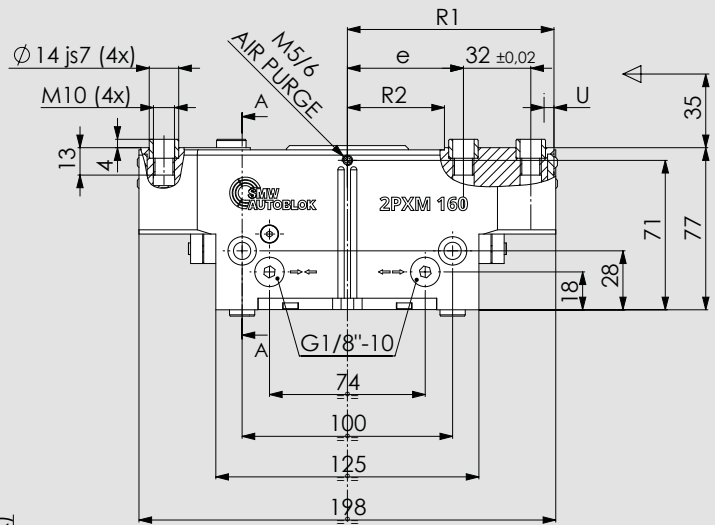
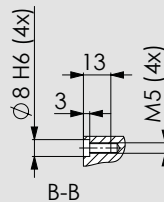
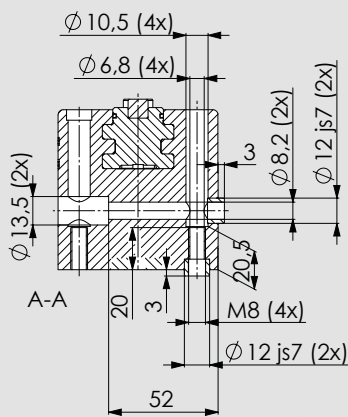
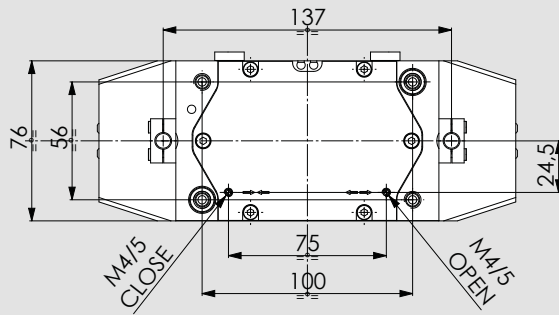

200

2PXM

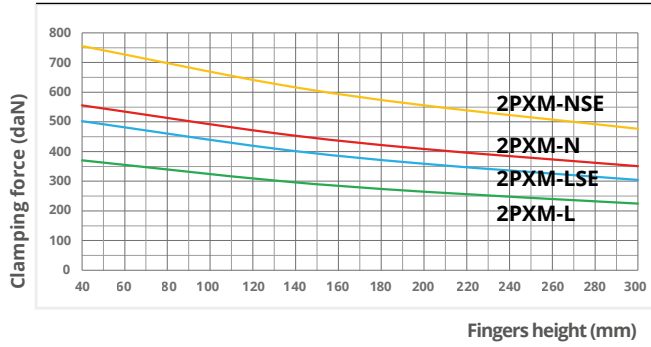

Clamping force calculated at **6 bar**.
 Max. recommended fingers height: **300 mm**
 Max. fingers weight: **6,7 Kg**
 For I.D. clamping consider **+5%** of the clamping force shown in the diagram.
 Use connecting screws **class 12.9**

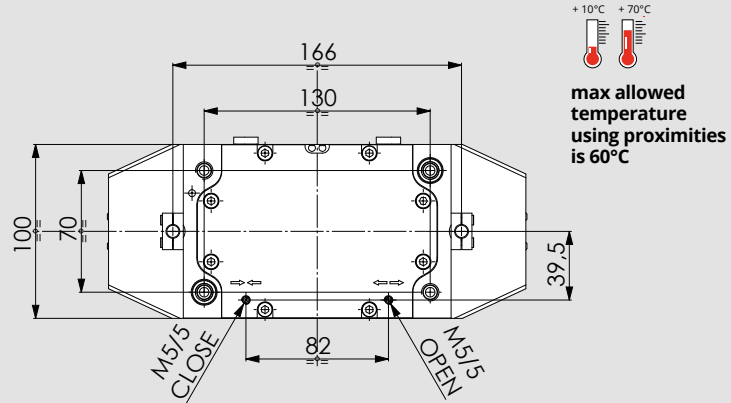
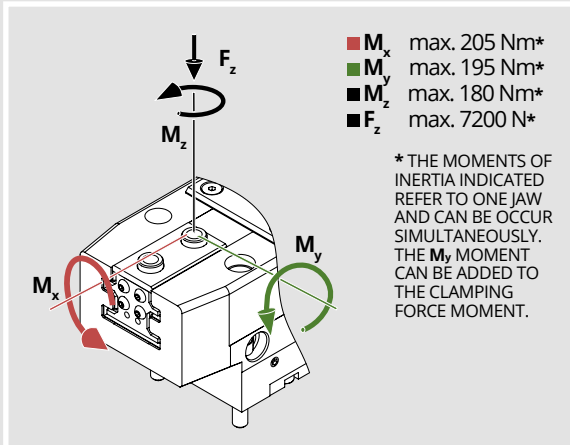

max allowed temperature using proximities is **60°C**

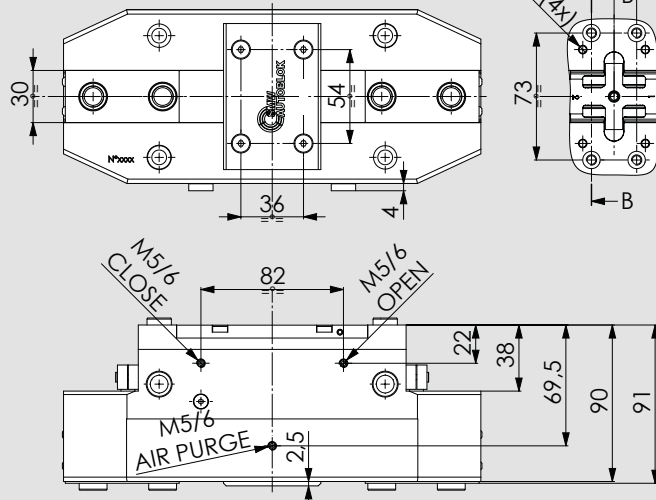
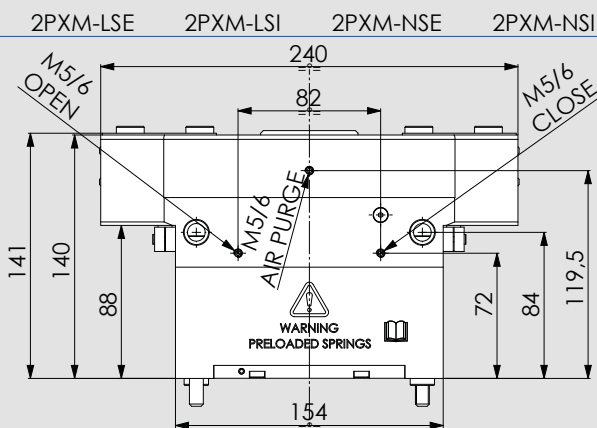
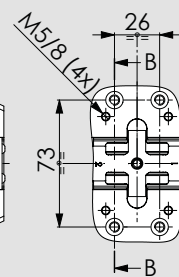
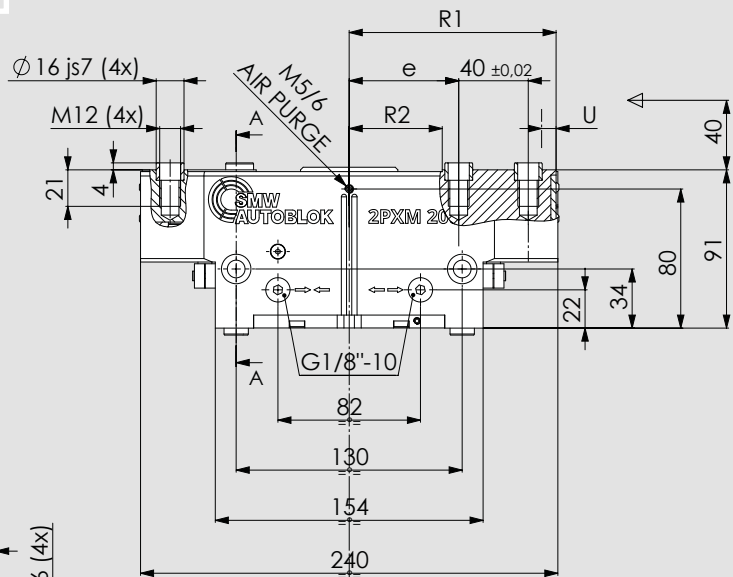
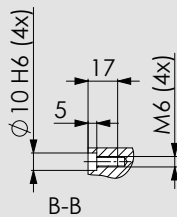
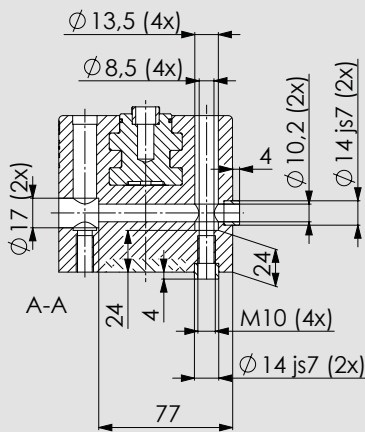

2PXL

2 jaws self-centering grippers Ø250

ALUMINIUM

Pneumatics - Protected



Technical features

- Aluminium body to contain the gripper weight
- Functional parts heat-treated for high precision and long life
- Jaws with calibrated bushings
- Protection class IP64
- Highest rigidity and repeatability: 0,04 mm
- Prepared for Air purge

OPTIONAL

- Inductive/Analogic stroke control sensor ON/OFF or linear
- Magnetic stroke control sensor ON/OFF or linear

Applications/Customer benefits

- Compact and light design
- OD and/or ID clamping (also with springs)
- Side or rear feeding and fixing
- Interchangeable with most existing universal grippers

Standard equipment

Grippers without fingers and without sensors.
All screws for the double mounting, all centering bushings and all interface OR included.

SMW-Autoblok TYPE	Id. No.	Clamping force (daN) at 6 bar	Spring force min. (daN)	U (mm) jaw stroke	Air volume (cm³)	Pressure (bar) min./max.	Opening/ Closing time (s) at 6 bar	Weight (Kg)	Workpiece weight recommended (Kg)	e (mm) min. /max.	R1 (mm) min. /max.	R2 (mm) min. /max.
2PXL-N 250	77901877	800	-----	17	651	2/8	0,5/0,5	8,4	40,0	46,75/63,75	122/139	37/54
2PXL-NSE 250	77902077	1100	300	17	1251	4/6,5	0,7/0,4	10,7	40,0	46,75/63,75	122/139	37/54
2PXL-NSI 250	77901177	1135	300	17	1278	4/6,5	0,4/0,7	10,7	40,0	46,75/63,75	122/139	37/54
2PXL-L 250	77901977	530	-----	30	651	2/8	0,5/0,5	8,2	26,5	46,75/76,75	109/139	37/67
2PXL-LSE 250	77902177	730	200	30	1251	4/6,5	0,7/0,4	10,5	26,5	46,75/76,75	109/139	37/67
2PXL-LSI 250	77901277	755	200	30	1278	4/6,5	0,4/0,7	10,5	26,5	46,75/76,75	109/139	37/67

Note: 2PXL-N: Normal stroke 2PXL-L: Long stroke 2PXL-NSE: Normal stroke OD 2PXL-NSI: Normal stroke ID
2PXL-LSE: Long stroke with springs OD 2PXL-LSI: Long stroke with springs ID

250

2PXL

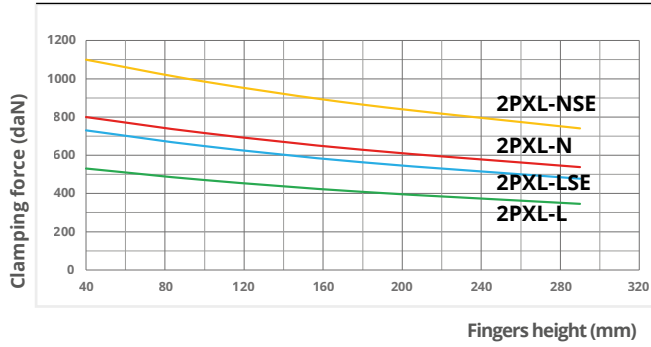

Clamping force calculated at **6 bar**.
Max. recommended fingers height: **290 mm**
Max. fingers weight: **9,2 Kg**
For I.D. clamping consider **+3%** of the clamping force shown in the diagram.
Use connecting screws **class 12.9**

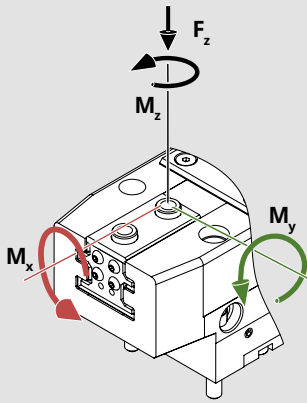

- M_x max. 270 Nm*
- M_y max. 255 Nm*
- M_z max. 220 Nm*
- F_z max. 8750 N*

* THE MOMENTS OF INERTIA INDICATED REFER TO ONE JAW AND CAN BE OCCUR SIMULTANEOUSLY. THE M_y MOMENT CAN BE ADDED TO THE CLAMPING FORCE MOMENT.

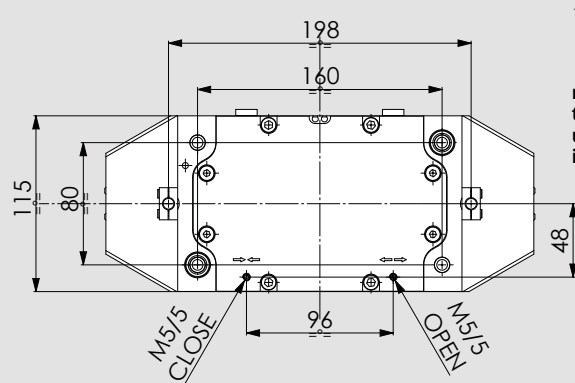

max allowed temperature using proximities is 60°C

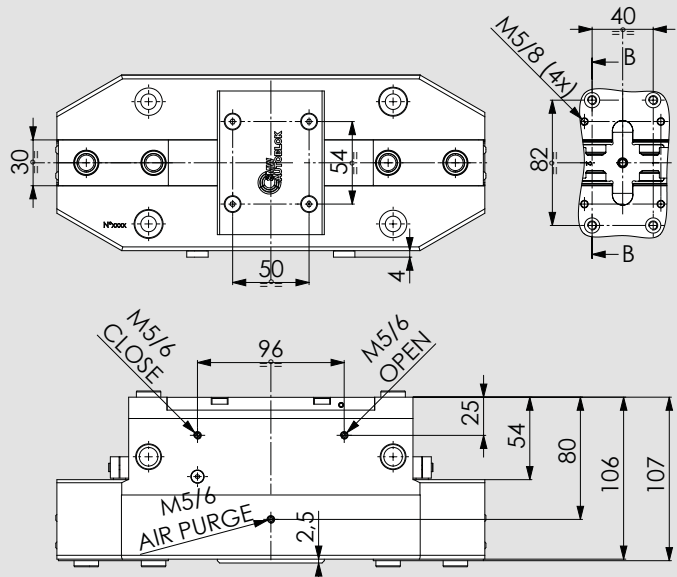
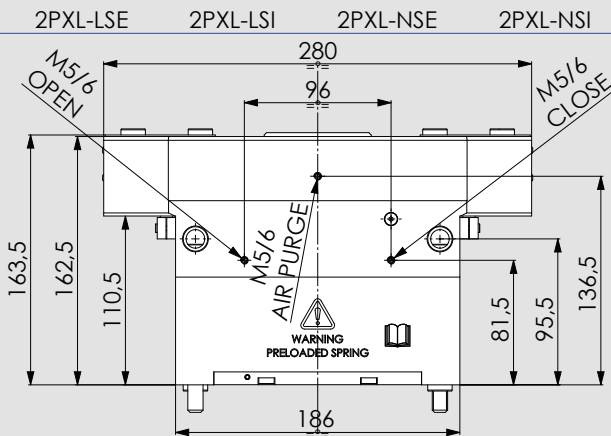
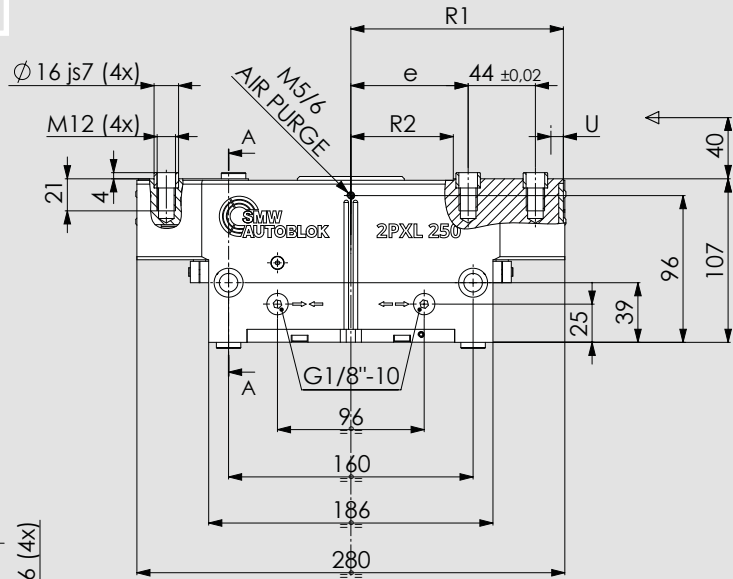
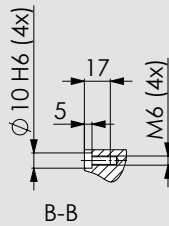
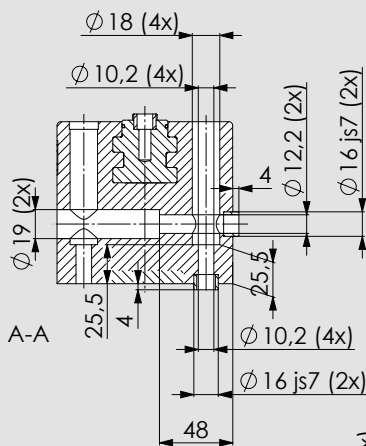

INDUCTIVE ON/OFF SENSOR

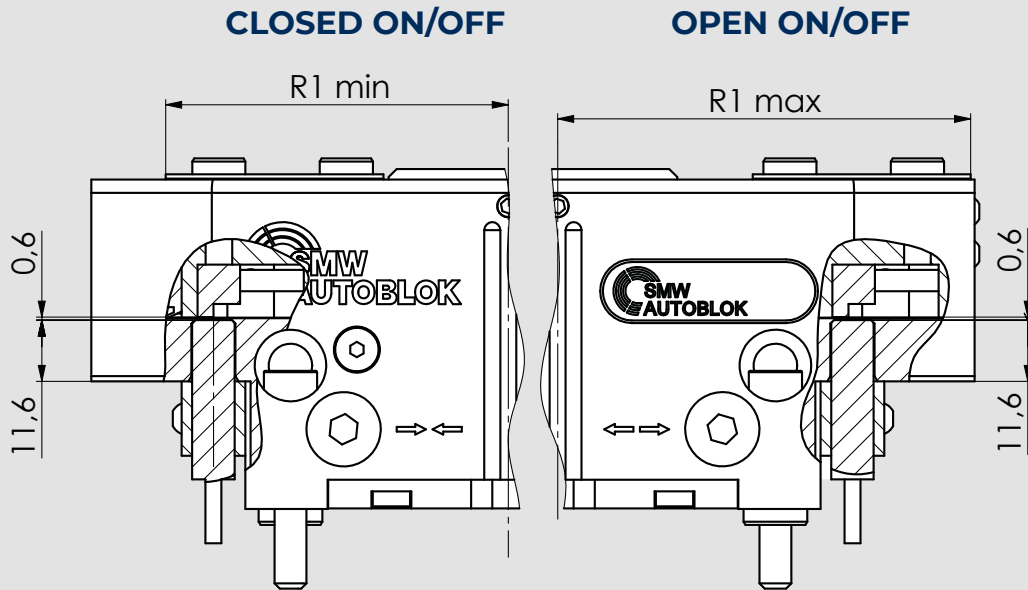

SMW-AUTOBLOK Type
CYLINDRICAL SENSOR M8x1 L=30

SENSOR Id.N. (*)
0E012802

(*) Id.n. refers to n.1 sensor. for more details ask the data sheet.

ANALOGIC LINEAR SENSOR

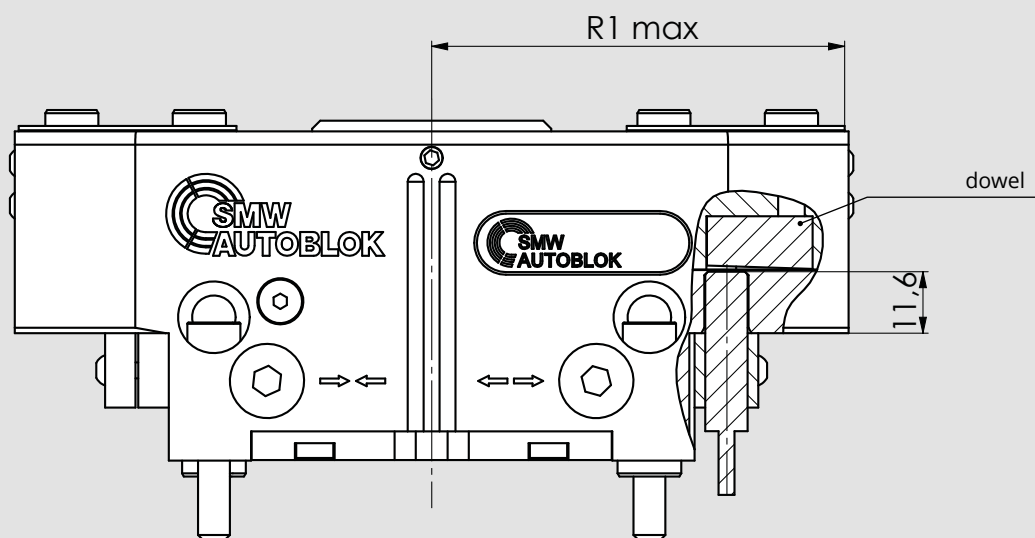

SMW-AUTOBLOK Type
CYLINDRICAL SENSOR M8x1 L=40

SENSOR Id.N. (*)
0E012810

DOWEL Id.N. ()**
92262163

(*) For more details ask the data sheet.
 (**) analogic sensor used must be specified in case of order to mount the right dowel.

SENSORS for 2PXS 2PXM 2PXL GRIPPERS

MAGNETIC ON/OFF SENSOR

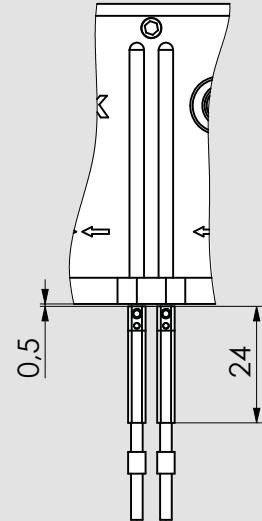
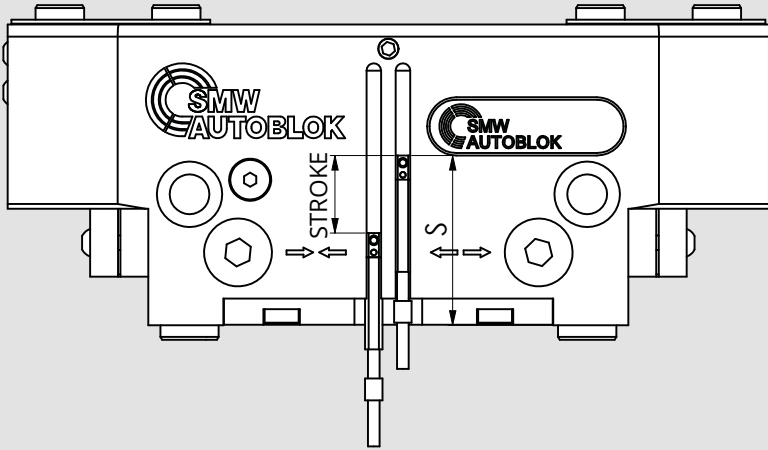

SMW-AUTOBLOK Type

MAGNETIC SENSOR Balluff**

SENSOR Id.N. (*)

BMF00P0

(*) Id.n. refers to n.1 sensor. for more details ask the data sheet.
 (**) or similars

MAGNETIC LINEAR SENSOR

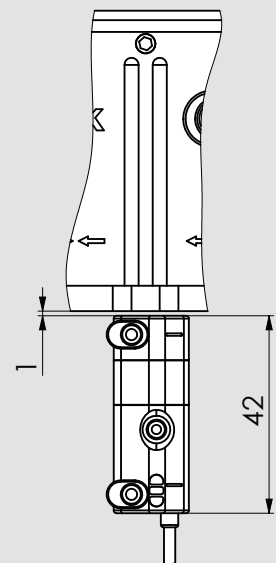
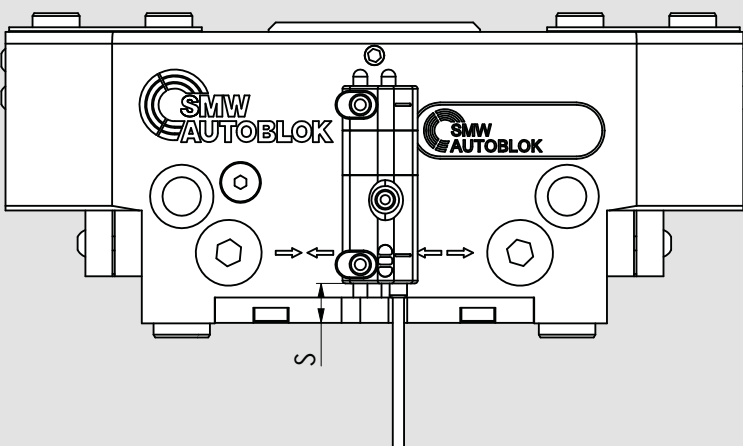

SMW-AUTOBLOK Type

ANALOGIC MAGNETIC SENSOR Balluff**

SENSOR Id.N. (*)

BMP0008

(*) for more details ask the data sheet.
 (**) or similars

GRIPPERS

with 3-master jaws
for precise handling
of workpieces

TWO TYPES OF 3-GRIPPERS

3MN

3PXS 3PXM 3PXL

Type	Size									Jaws			Stroke		Quick jaw change	Clamping	
	64	80	100	125	160	200	250	320	380	n°	Tongue & Groove	Bush	Normal	Long		OD	ID
										3							
3MN	64									3				3MN-L			
		80								3				3MN-L			
			80							3				3MNS-L			
				100						3				3MN-L			
					100					3				3MNS-L			
						125				3				3MN-L			
							125			3				3MNS-L			
								160		3			3MNN-N	3MN-L			
									160	3			3MNS-N	3MNS-L			
										200	3		3MNN-N	3MN-L			
											200	3	3MNS-N	3MNS-L			
												250	3MNN-N	3MN-L			
													250	3MNS-N	3MNS-L		
														320	RR		
													320	RR			
													380	RR			
													380	RR			
3PXS	64									3			3PXS-N	3PXS-L			
		80								3			3PXS-N	3PXS-L			
			100							3			3PXS-N	3PXS-L			
		64								3			3PXS-NS	3PXS-LS	E	I	
			80							3			3PXS-NS	3PXS-LS	E	I	
				100						3			3PXS-NS	3PXS-LS	E	I	
3PXM				125						3			3PXM-N	3PXM-L			
					160					3			3PXM-N	3PXM-L			
						200				3			3PXM-N	3PXM-L			
					125					3			3PXM-NS	3PXM-LS	E	I	
						160				3			3PXM-NS	3PXM-LS	E	I	
							200			3			3PXM-NS	3PXM-LS	E	I	
3PXL													250	3PXL-L			
													250	3PXL-NS	3PXL-LS	E	I

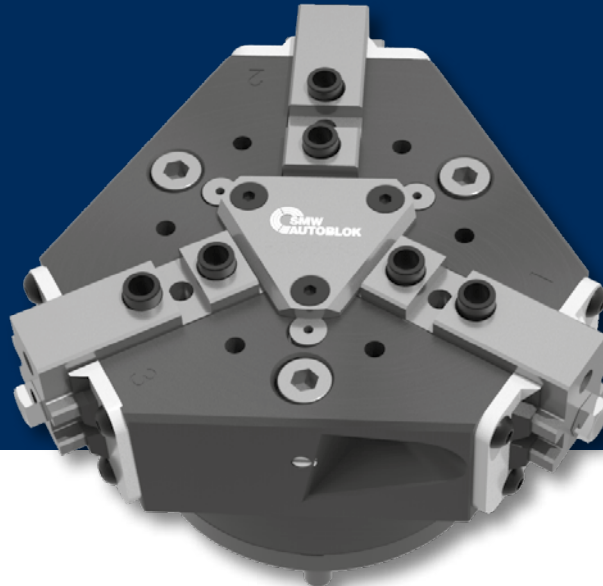

Material	Stroke control types:					Air purge	Springs	Protection IEC 60529
	a	b	c	d	e			
Alum	pneumatic valve	linear analogic	inductive ON/OFF	linear magnetic	magnetic ON/OFF			
		b						IP64
		b						IP64
		b						IP64
		b						IP64
		b						IP64
		b						IP64
		b						IP64
		b						IP64
		b						IP64
	a	b						IP64
	a	b						IP64
	a	b						IP64
	a	b						IP64
	a	b						IP64
	a	b						IP64
	a	b						IP64
	a	b						IP64
		b	c	d	e			IP40
		b	c	d	e			IP40
		b	c	d	e			IP40
		b	c	d	e			IP40
		b	c	d	e			IP40
		b	c	d	e			IP40
		b	c	d	e			IP64
		b	c	d	e			IP64
		b	c	d	e			IP64
		b	c	d	e			IP64
		b	c	d	e			IP64
		b	c	d	e			IP64
		b	c	d	e			IP64

3MN

3 jaws self-centering grippers Ø64-80-100 sizes

ALUMINIUM

Pneumatics - Protected

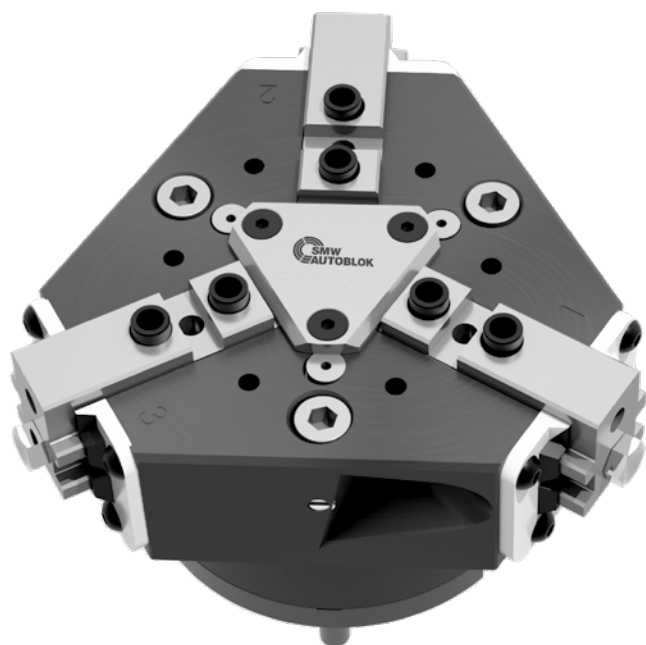

Technical features

- Aluminium body to contain the gripper weight
- Functional parts heat-treated for high precision and long life
- Jaws with calibrated bushings and groove
- Protection class IP64
- Highest rigidity and Repeatability: 0,01 mm
- Prepared for Air purge

OPTIONAL:

- Spring workstop
- Analogic linear stroke control sensor

Applications/Customer benefits

- Compact and light design
- O.D. (also with springs) and/or I.D. clamping
- Integrated greasing system on jaws (use SMW-Autoblok K67 grease)

Standard equipment

Grippers without fingers and without sensors.
All screws for the double mounting, all centering bushings and all interface OR included.

SMW-Autoblok Type	Id. No.	Clamping force (daN) at 6 bar	Spring force min. (daN)	U (mm) jaw stroke	Air volume (cm ³)	Pressure (bar) min./max.	Closing/Opening time (s) at 6 bar	Weight (Kg)	Workpiece weight recommended (Kg)	e (mm) min./max.	R (mm) min./max.	R1 (mm) min./max.
3MN-L 64	77920106	60	-----	6	16	2/8	0,03/0,03	0,8	4,0	17,5/23,5	24/30	50,8/56,8
3MNS-L 64	77920206	68,5	8,5	6	16	4/6,5	0,04/0,02	0,85	4,0	17,5/23,5	24/30	50,8/56,8
3MN-L 80	77920108	105	-----	8	37	2/8	0,05/0,05	1,3	7,0	22/30	30/38	58/66
3MNS-L 80	77920208	125	20	8	37	4/6,5	0,05/0,03	1,4	7,0	22/30	30/38	58/66
3MN-L 100	77920110	180	-----	10	79,5	2/8	0,05/0,05	2	12,0	27,5/37,5	37,5/47,5	66,5/76,5
3MNS-L 100	77920210	225	45	10	79,5	4/6,5	0,05/0,03	2,2	12,0	27,5/37,5	37,5/47,5	66,5/76,5

Note: 3MN-L: Long stroke 3MNS-L: Long stroke with springs

64

3MN

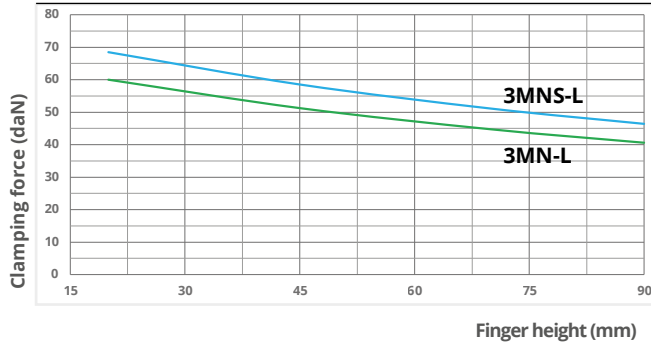

Clamping force calculated at **6 bar**.

Max. recommended fingers height: **90 mm**

Max. Fingers weight: **0,3 Kg**

For I.D. clamping consider **+10%** of the clamping force shown in the diagram.

Use connecting screws **class 12.9**

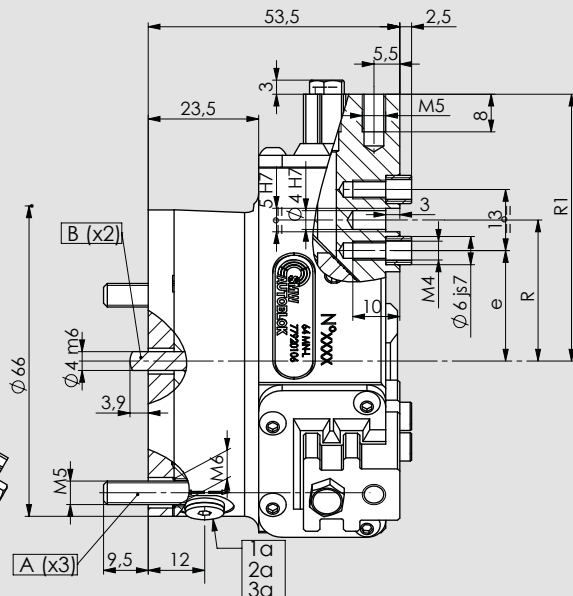
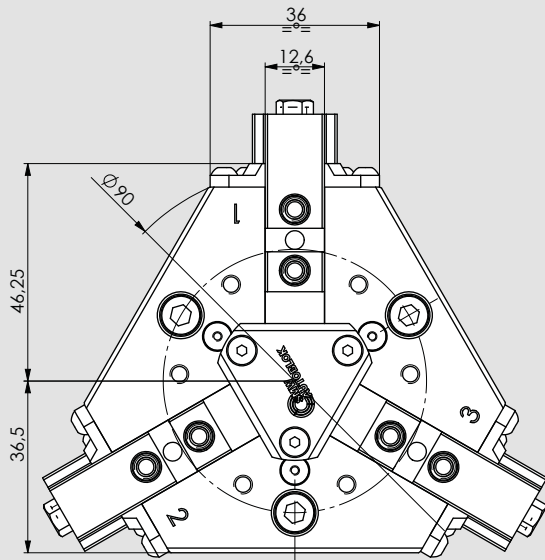
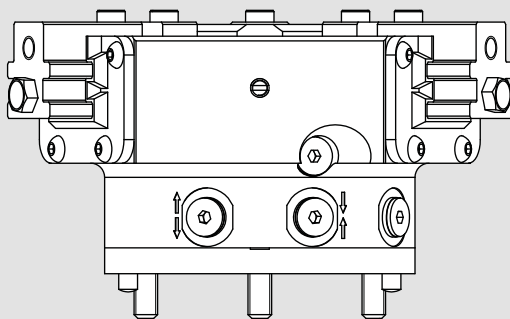
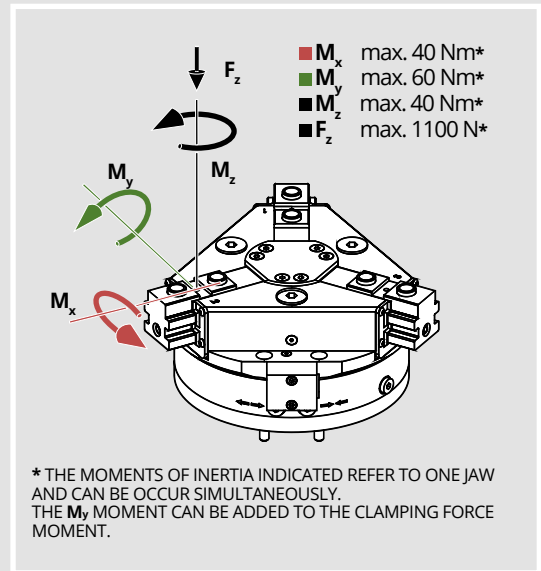
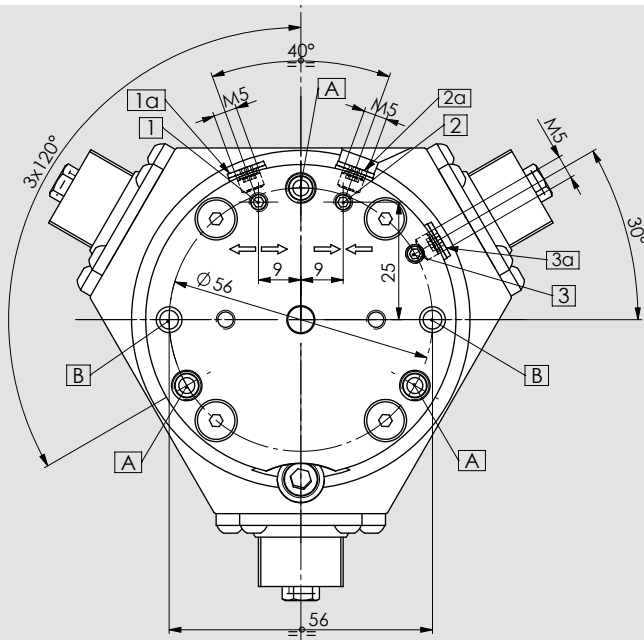

maximum allowed temperature using proximities is 60°C

80

3MN

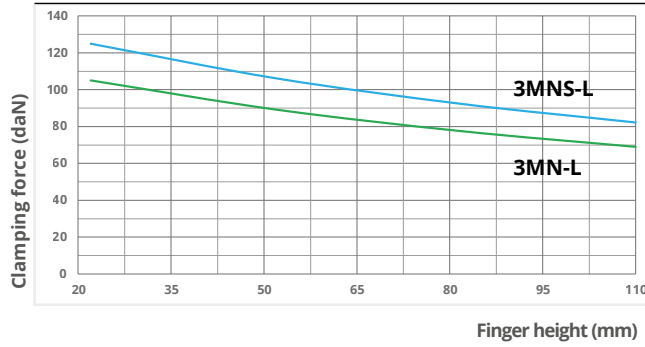

Clamping force calculated at **6 bar**.
 Max. recommended fingers height: **110 mm**
 Max. Fingers weight: **0,6 Kg**
 For I.D. clamping consider **+10%** of the clamping force shown in the diagram.
 Use connecting screws **class 12.9**

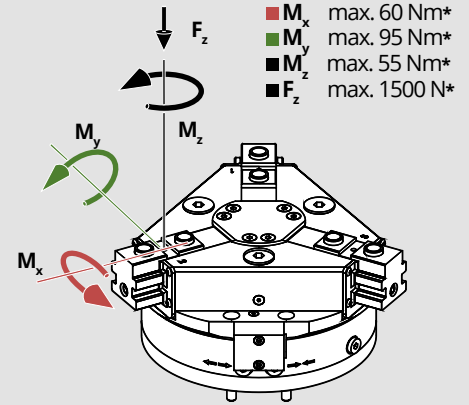
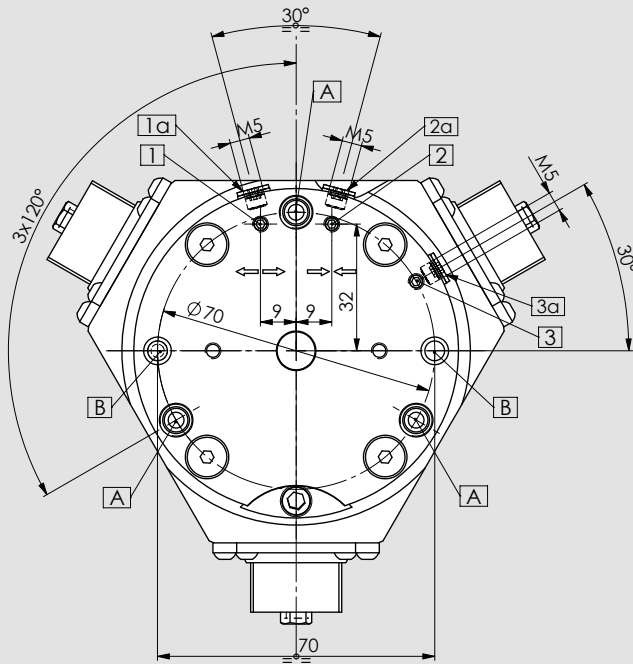

* THE MOMENTS OF INERTIA INDICATED REFER TO ONE JAW AND CAN BE OCCUR SIMULTANEOUSLY. THE M_y MOMENT CAN BE ADDED TO THE CLAMPING FORCE MOMENT.

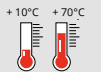

maximum allowed temperature using proximities is 60°C

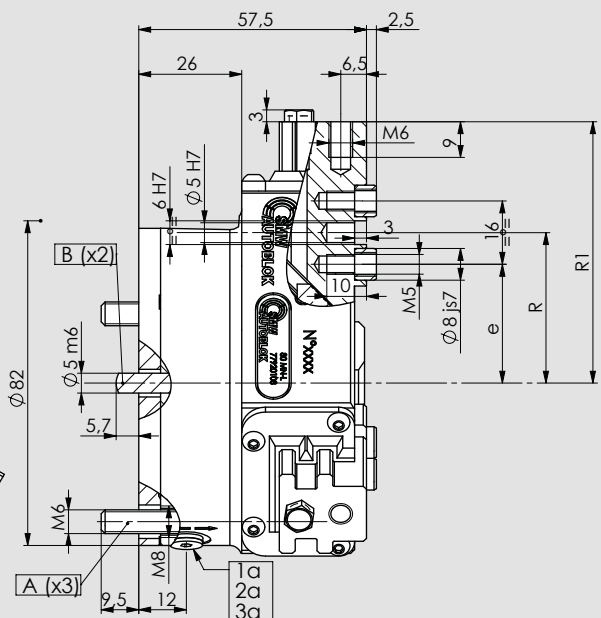
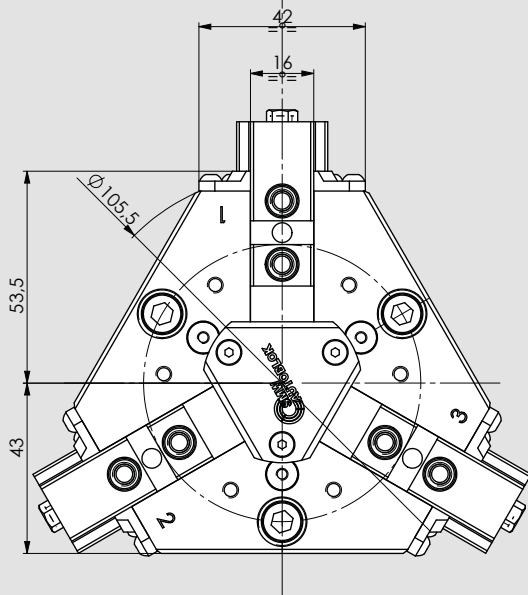
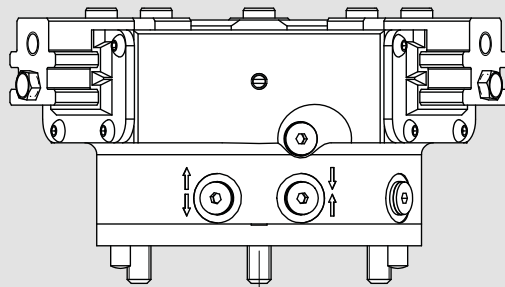

100

3MN

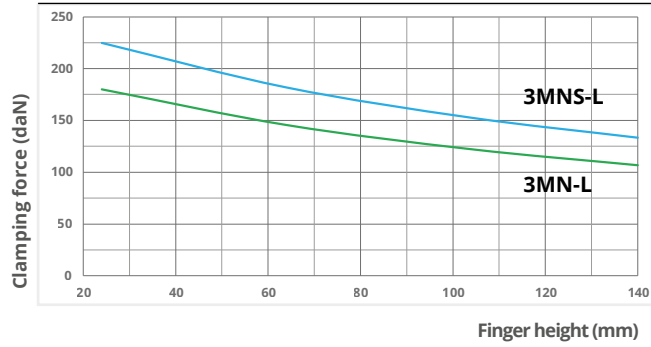

Clamping force calculated at **6 bar**.

Max. recommended fingers height: **140 mm**

Max. Fingers weight: **1,1 Kg**

For I.D. clamping consider **+7%** of the clamping force shown in the diagram.

Use connecting screws **class 12.9**

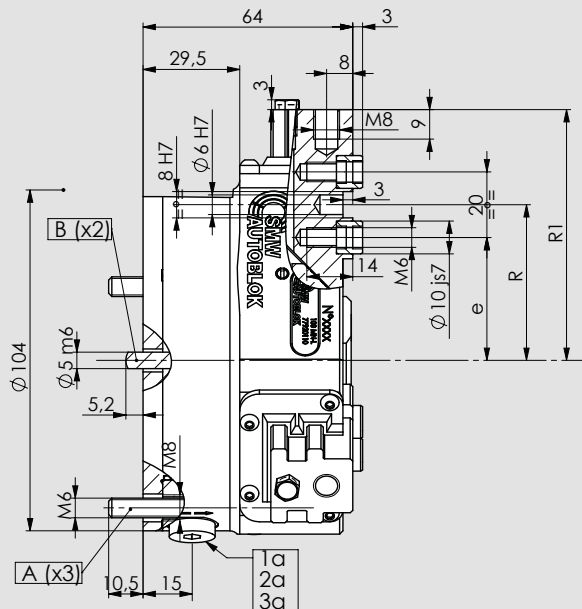
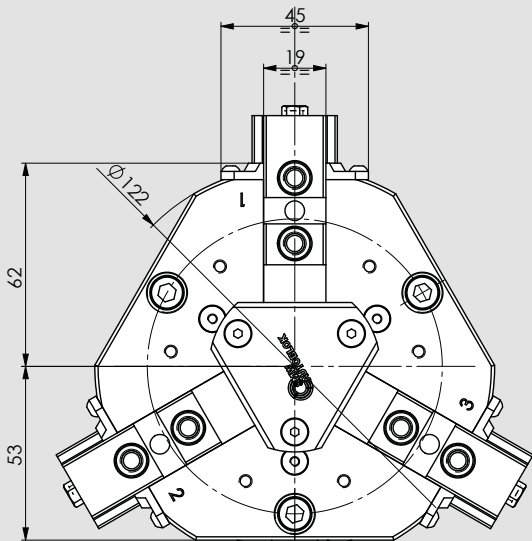
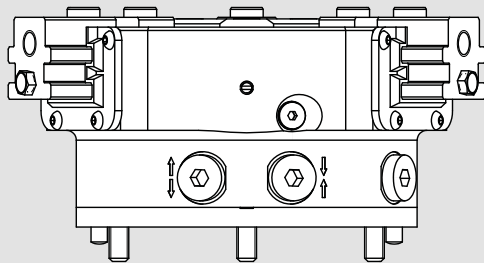
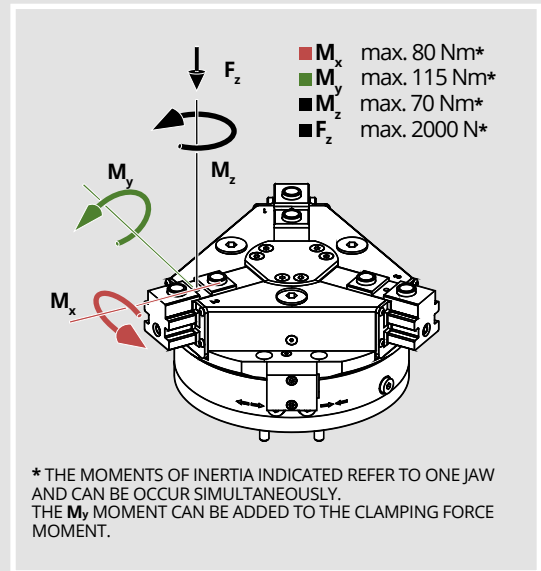
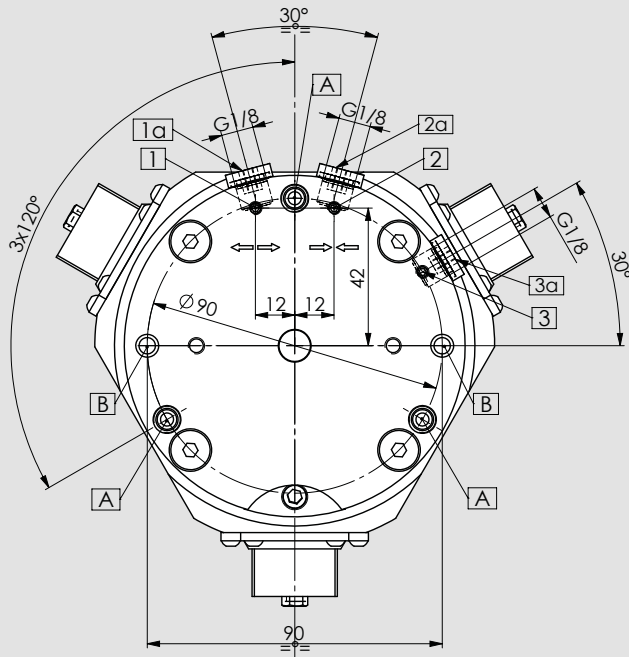

maximum allowed temperature using proximities is 60°C

3MN

3 jaws self-centering grippers Ø125-160-200-250

ALUMINIUM

Pneumatics - Protected



Technical features

- Aluminium body to contain the gripper weight
- Functional parts heat-treated for high precision and long life
- Jaws with calibrated bushings and groove
- Protection class IP64
- Highest rigidity and Repeatability: 0,02 mm
- Prepared for Air purge
- SAB-1 STD safety valve

OPTIONAL:

- Spring workstop
- Analogic linear stroke control sensor
- Pneumatic stroke control valve (only Ø200 and 250 sizes)

Applications /Customer benefits

- Compact and light design
- O.D. (also with springs) and/or I.D. clamping
- Integrated greasing system on jaws (use SMW-Autoblok K67 grease)

Standard equipment

Grippers without fingers and without sensors.
All screws for the double mounting, all centering bushings, all interface OR and SAB-1 STANDARD safety valve included.

SMW-Autoblok Type	Id. No.	Clamping force (daN) at 6 bar	Spring force min. (daN)	U (mm) jaw stroke	Air volume (cm³)	Pressure (bar) min./max.	Closing/Opening time (s) at 6 bar	Weight (Kg)	Workpiece weight recommended (Kg)	e (mm) min./max.	R (mm) min./max.	R1 (mm) min./max.
3MN-N 125	77920412	600	----	6	169	2/8	0,2/0,2	3,8	30,0	35/41	47/53	76/82
3MN-L 125	77920112	300	----	13	169	2/8	0,2/0,2	3,8	15,0	35/48	47/60	76/89
3MN-N 160	77920416	1000	----	8	418	2/8	0,5/0,5	6	50,0	45/53	61/69	90/98
3MNS-N 160	77920516	1340	340	8	418	4/6,5	0,7/0,4	6,5	50,0	45/53	61/69	90/98
3MN-L 160	77920116	610	----	16	418	2/8	0,5/0,5	6	30,5	45/61	61/77	90/106
3MNS-L 160	77920216	820	210	16	418	4/6,5	0,7/0,4	6,5	30,5	45/61	61/77	90/106
3MN-N 200	77920420	1275	----	14	806,5	2/8	1,2/1,2	12	64,0	49/63	69/83	109/123
3MNS-N 200	77920520	1875	600	14	806,5	4/6,5	1,5/1	12,5	64,0	49/63	69/83	109/123
3MN-L 200	77920120	720	----	25	806,5	2/8	1,2/1,2	12	36,0	49/74	69/94	109/134
3MNS-L 200	77920220	1050	330	25	806,5	4/6,5	1,5/1	12,5	36,0	49/74	69/94	109/134
3MN-N 250	77920425	1845	----	17	1389	2/8	1,3/1,3	17	92,0	57/74	79/96	127/144
3MNS-N 250	77920525	2645	800	17	1389	4/6,5	2,1/1,1	17,5	92,0	57/74	79/96	127/144
3MN-L 250	77920125	1035	----	30	1389	2/8	1,3/1,3	17	52,0	57/87	79/109	127/157
3MNS-L 250	77920225	1485	450	30	1389	4/6,5	2,1/1,1	18	52,0	57/87	79/109	127/157

Note: 3MN-N: Normal stroke 3MN-L: Long stroke 3MNS-N: Normal stroke with springs 3MNS-L: Long stroke with springs

160

3MN

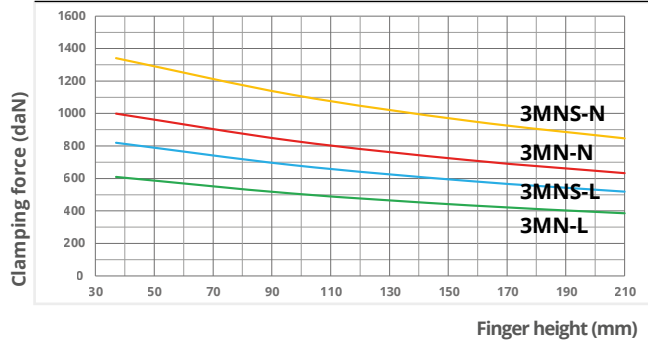

Clamping force calculated at **6 bar**.
 Max. recommended fingers height: **210 mm**
 Max. Fingers weight: **4,5 Kg**
 For I.D. clamping consider **+5%** of the clamping force shown in the diagram.
 Use connecting screws **class 12.9**

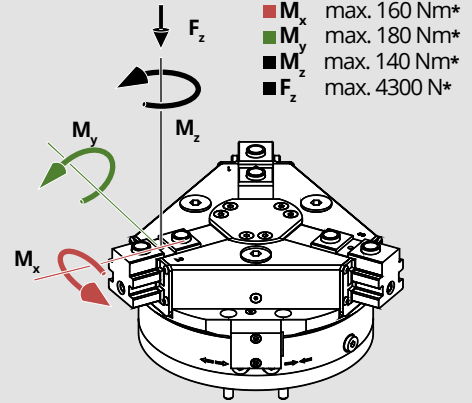
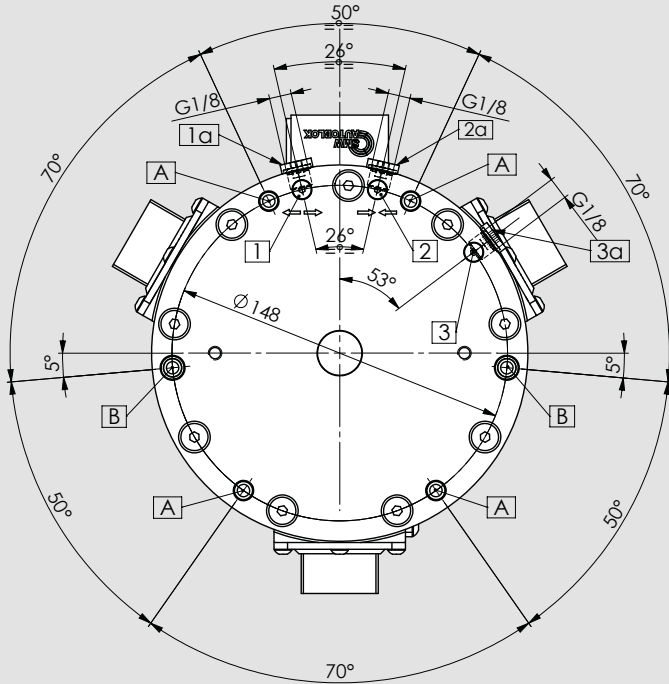

* THE MOMENTS OF INERTIA INDICATED REFER TO ONE JAW AND CAN BE OCCUR SIMULTANEOUSLY. THE M_y MOMENT CAN BE ADDED TO THE CLAMPING FORCE MOMENT.

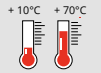

maximum allowed temperature using proximities is 60°C

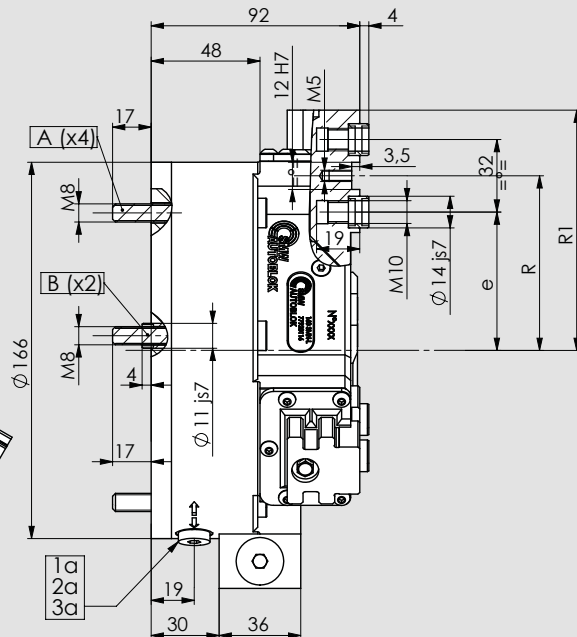
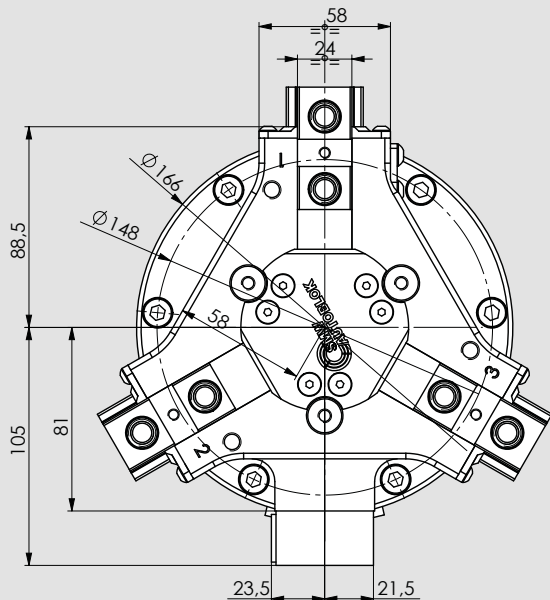
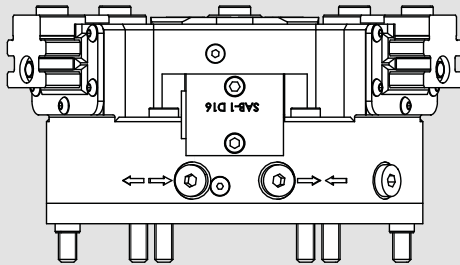

250

3MN

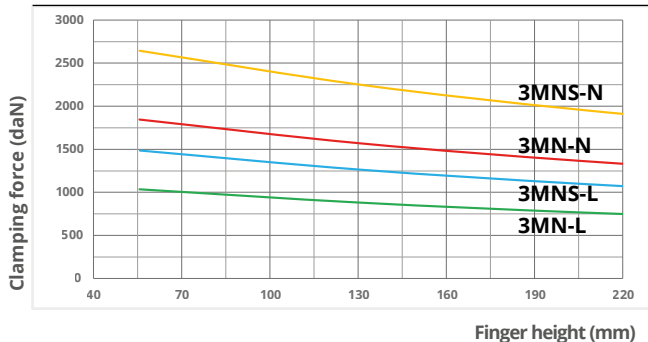

Clamping force calculated at **6 bar**.
 Max. recommended fingers height: **280 mm**
 Max. Fingers weight: **8,5 Kg**
 For I.D. clamping consider **+3%** of the clamping force shown in the diagram.
 Use connecting screws **class 12.9**

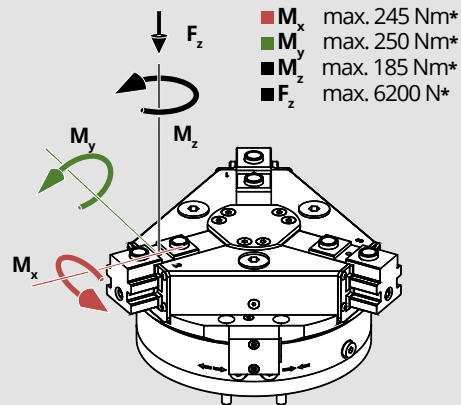
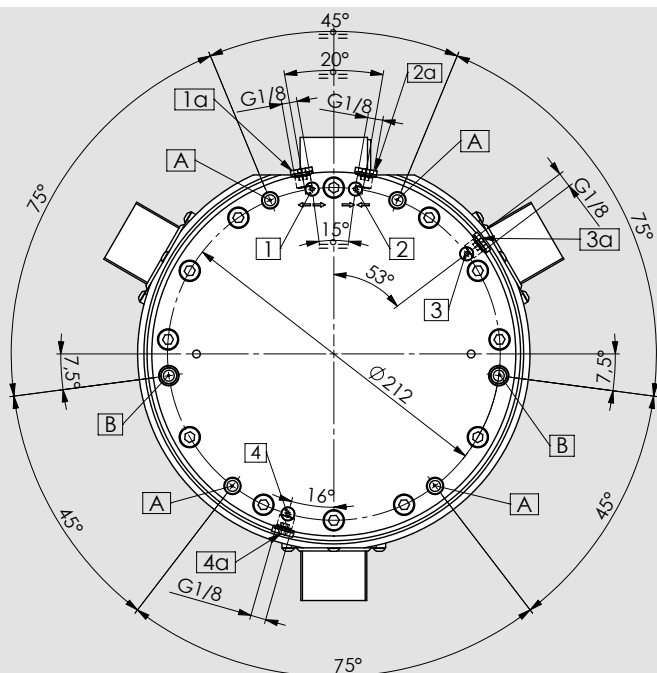

- M_x max. 245 Nm*
- M_y max. 250 Nm*
- M_z max. 185 Nm*
- F_z max. 6200 N*

* THE MOMENTS OF INERTIA INDICATED REFER TO ONE JAW AND CAN BE OCCUR SIMULTANEOUSLY. THE M_y MOMENT CAN BE ADDED TO THE CLAMPING FORCE MOMENT.



maximum allowed temperature using proximities is 60°C

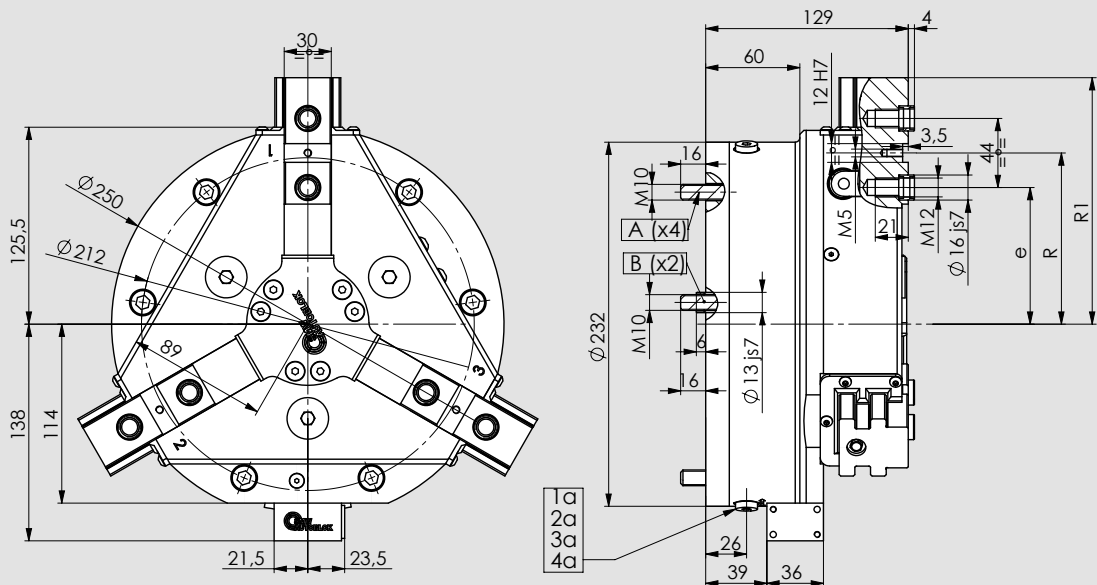
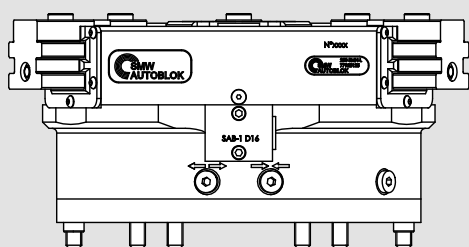

3MN

3 jaws self-centering grippers Ø320-380

ALUMINIUM

Pneumatics - Protected - Quick jaws change



Technical features

- Aluminium body to contain the gripper weight
- Functional parts heat-treated for high precision and long life
- Jaws with calibrated bushings and groove
- Protection class IP64
- Highest rigidity and Repeatability: 0,04 mm
- Prepared for Air purge
- Safety valve SAB-1 STD

OPTIONAL:

- Spring workstop
- Analogic linear stroke control sensor
- Quick change RR jaws

Applications/Customer benefits

- Compact and light design
- O.D. (also with springs) and/or I.D. clamping
- Integrated greasing system on jaws (use SMW-Autoblok K67 grease)

Standard equipment

Grippers without fingers and without sensors.
All screws for the double mounting, all centering bushings, all interface OR and SAB-1 STANDARD safety valve included.

SMW-Autoblok Type	Id. No.	Clamping force (daN) at 6 bar	Spring force min. (daN)	U (mm) jaw stroke	Air volume (cm³)	Pressure (bar) min./max.	Closing/Opening time (s) at 6 bar	Weight (Kg)	Workpiece weight recommended (Kg)	e (mm) min./max.	R (mm) min./max.	R1 (mm) min./max.
3MN-N 320	77920432	2740	----	20,9	2669,5	2/8	1,3/1,3	44	137,0	79,5/100,4	102,5/123,4	173/193,9
3MN-N 320 RR	77920932									----	116,5/137,4	173/193,9
3MNS-N 320	77920532	3340	600	20,9	2669,5	4/6,5	2,5/1,2	45	137,0	79,5/100,4	102,5/123,4	173/193,9
3MNS-N 320 RR	77921032									----	116,5/137,4	173/193,9
3MN-L 320	77920132	1500	----	40	2669,5	2/8	1,3/1,3	44	75,0	79,5/119,5	102,5/142,5	173/213
3MN-L 320 RR	77920732									----	116,5/156,5	173/213
3MNS-L 320	77920232	2590	1090	40	2669,5	4/6,5	2,5/1,2	45	75,0	79,5/119,5	102,5/142,5	173/213
3MNS-L 320 RR	77920832									----	116,5/156,5	173/213
3MN-N 380	77920438	4500	----	26	5405	2/8	2,1/2,1	64	225,0	90/116	122/148	197/223
3MN-N 380 RR	77920938									----	140,5/166,5	197/223
3MNS-N 380	77920538	5850	1350	26	5405	4/6,5	2,9/1,8	66	225,0	90/116	122/148	197/223
3MNS-N 380 RR	77921038									----	140,5/166,5	197/223
3MN-L 380	77920138	2450	----	50	5405	2/8	2,1/2,1	64	122,5	90/140	122/172	197/247
3MN-L 380 RR	77920738									----	140,5/190,5	197/247
3MNS-L 380	77920238	3200	750	50	5405	4/6,5	2,9/1,8	66	122,5	90/140	122/172	197/247
3MNS-L 380 RR	77920838									----	140,5/190,5	197/247

Note: 3MN-N: Normal stroke 3MN-L: Long stroke 3MNS-N: Normal stroke with springs 3MNS-L: Long stroke with springs
3MN-.-.RR: Quick change RR jaws

Drawings and data are subject to change by SMW-Autoblok.

320

3MN-RR

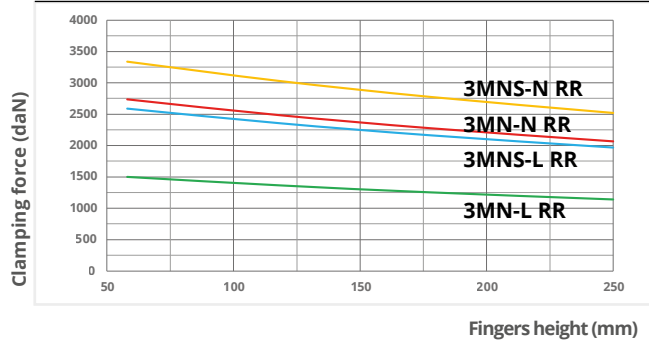

Clamping force calculated at **6 bar**.

Max. recommended fingers height: **250 mm**

Max. Fingers weight: **11,5 Kg**

For I.D. clamping consider **+3%** of the clamping force shown in the diagram.

Use connecting screws **class 12.9**

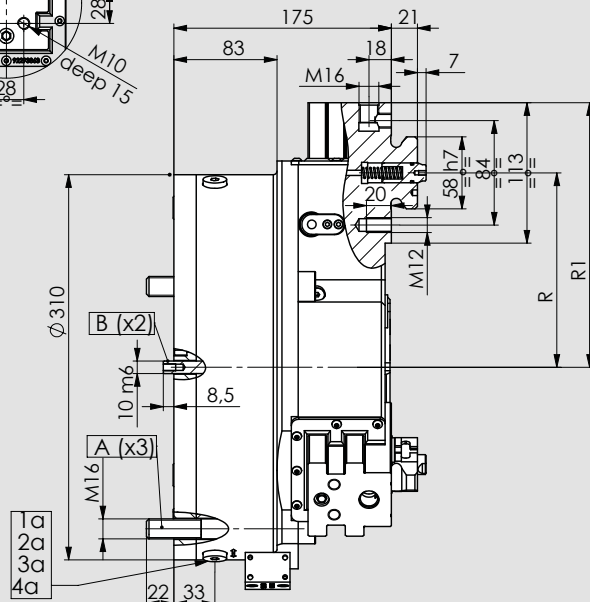
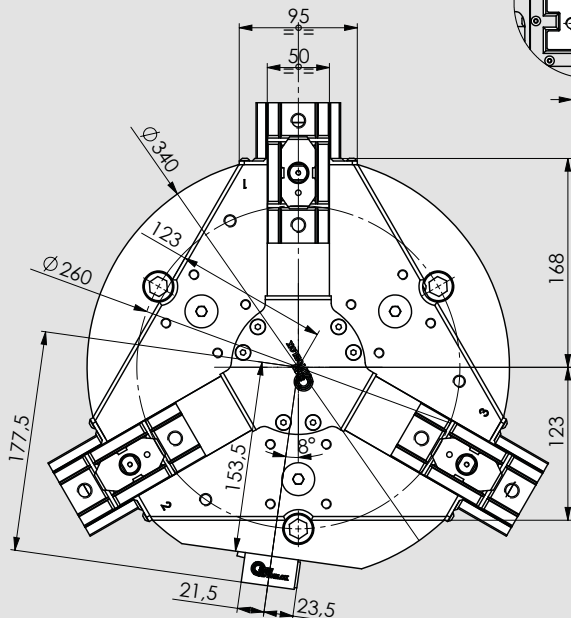
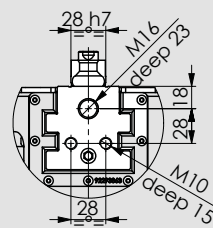
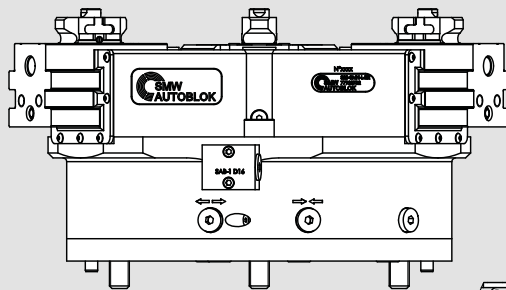
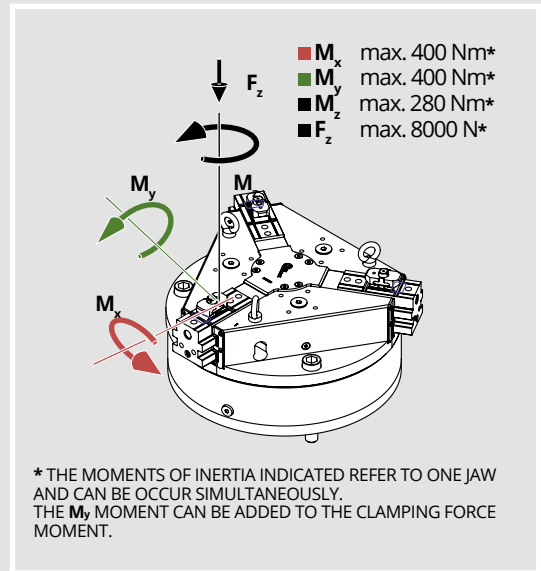
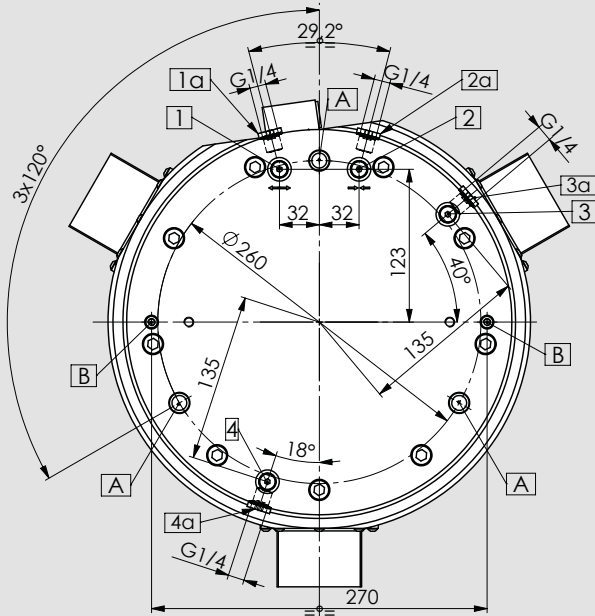

maximum allowed temperature using proximities is 60°C

380

3MN

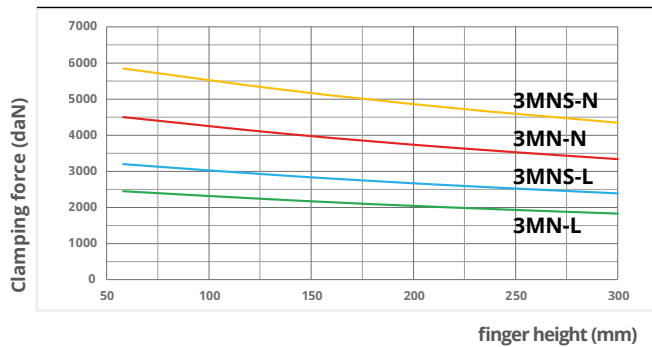

Clamping force calculated at **6 bar**.
Max. recommended fingers height: **300 mm**
Max. fingers weight: **14 Kg**
For I.D. clamping consider **+4%** of the clamping force shown in the diagram.
Use connecting screws **class 12.9**

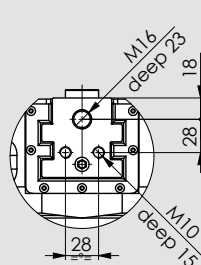
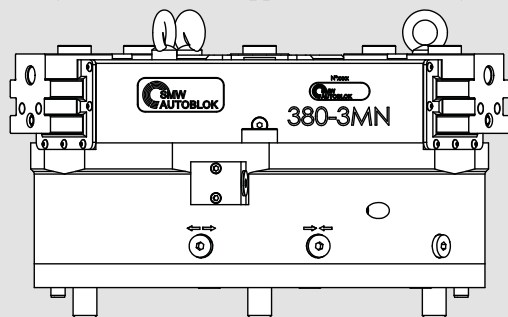
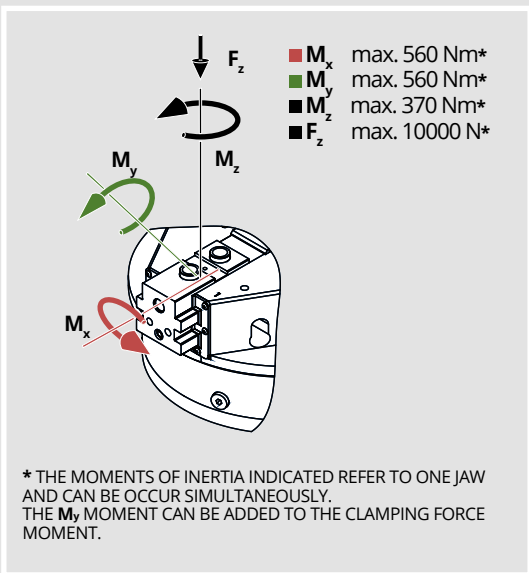
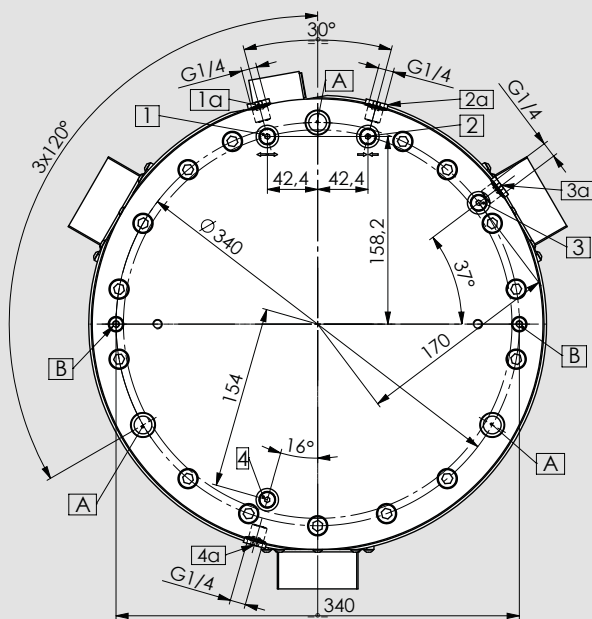

maximum allowed temperature using proximities is 60°C

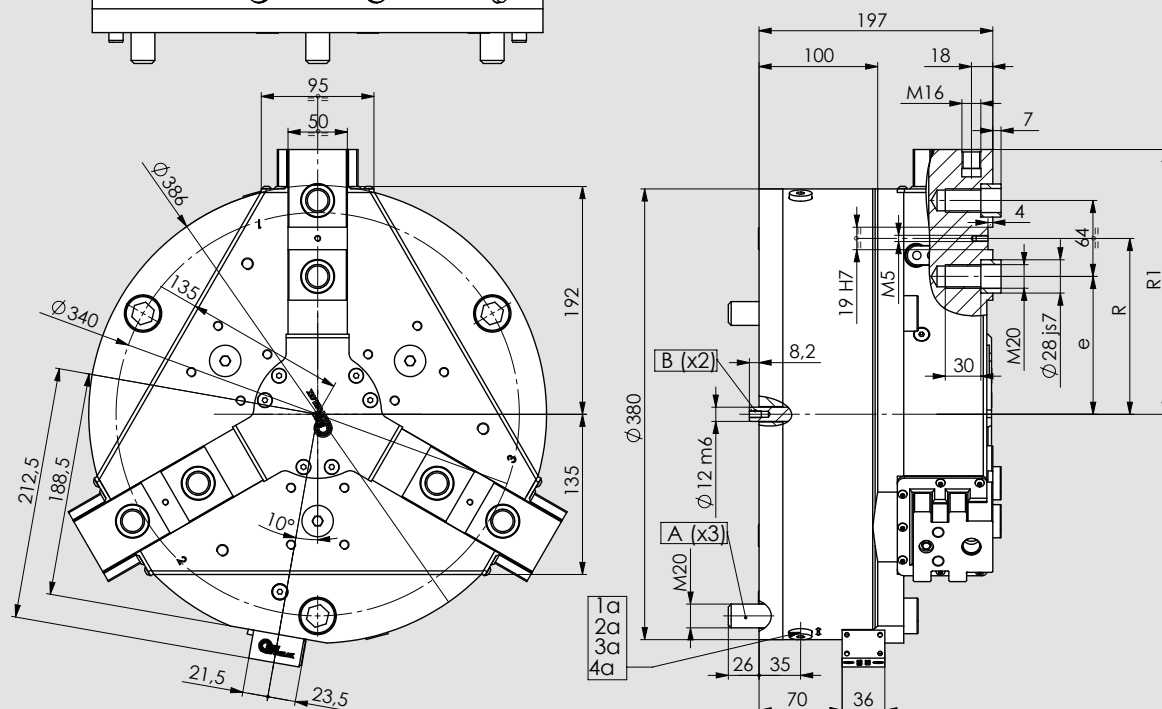

QUICK PALLET CHANGE

for 320 and 380 grippers sizes

O.D. Clamping

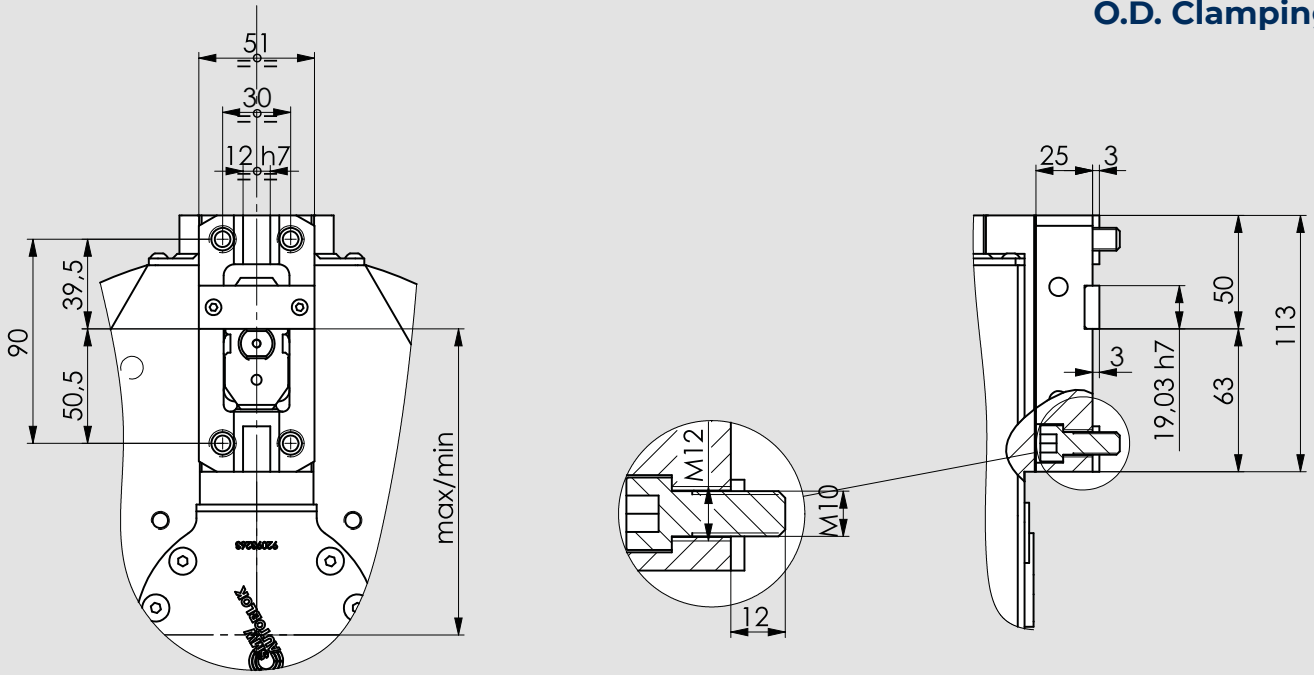

MODEL	PALLET ID.N.(*)	Max / min OD clamping
3MN-L 320 - RR	18762654	163 / 123
3MN-N 320 - RR		143,9 / 123
3MN-L 380 - RR		197 / 147
3MN-N 380 - RR		173,2 / 147

(*) the Id.n. refers to 1 single pallet

I.D. Clamping

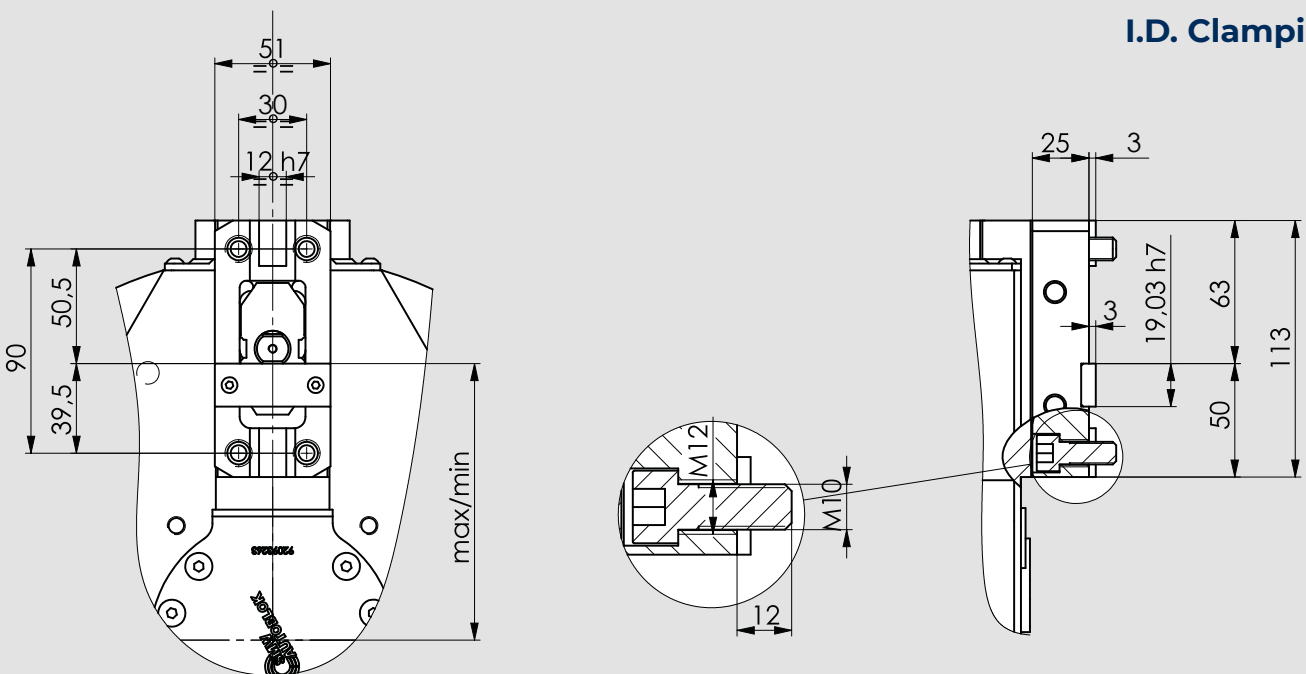

MODEL	PALLET ID.N.(*)	Max / min ID clamping
3MN-L 320 - RR	18762654	150 / 110
3MN-N 320 - RR		130,9 / 110
3MN-L 380 - RR		184 / 134
3MN-N 380 - RR		160,2 / 134

(*) the Id.n. refers to 1 single pallet

SPRING WORKSTOP

optional

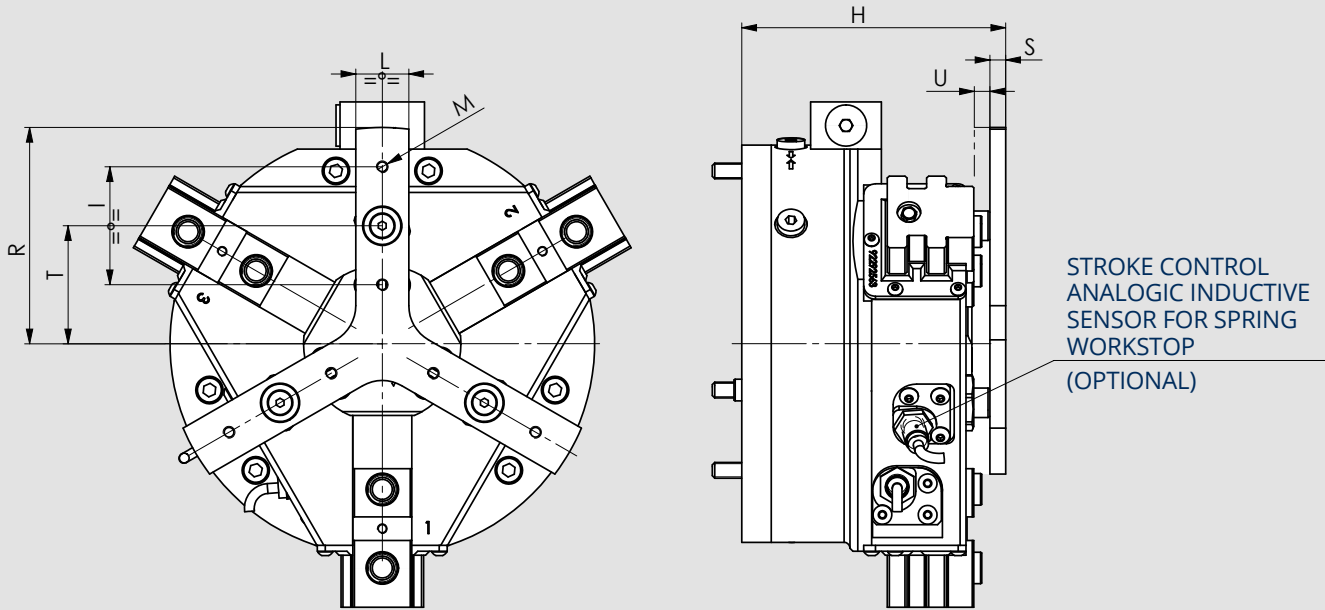

MODEL	ID.N. SPRING WORKSTOP KIT	H max/min mm	I mm	L mm	M	R mm	S mm	T mm	U stroke mm	FORCE min/max
64 3MN	92670663	62,5/58,5 mm	16 mm	10 mm	M4	35	4	19	4	10/14 N
80 3MN	92670863	66,5/62,5mm	16 mm	12 mm	M4	40	4	23	4	15/21 N
100 3MN	92671063	73/69 mm	20 mm	12 mm	M5	50	4	29	4	35/51 N
125 3MN	92671263	94,5/88,5 mm	40 mm	20 mm	M6	72,5	6	39	6	110/180 N
160 3MN	92671663	104/98 mm	40 mm	20 mm	M6	72,5	6	39	6	210/300 N
200 3MN	92672563	134/126 mm	60 mm	27 mm	M6	110	8	60	8	360/600 N
250 3MN	92672563	145/137 mm	60 mm	27 mm	M6	110	8	60	8	360/600 N
320 3MN	92673863	190/182 mm	60 mm	35 mm	M6	150	8	90	8	540/900 N
380 3MN	92673863	212/204 mm	60 mm	35 mm	M6	150	8	90	8	540/900 N

64 MN / 80 MN / 100 MN / 125 MN / 160 MN

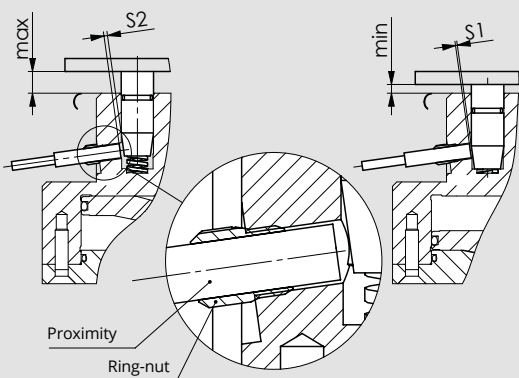

MODEL	BRACKET (not supplied)	PROXIMITY (not supplied)	S1 (±0,1)	S2 (±0,1)
64 3MN	BALLUFF BAM000U	BAUMER * IWRM04U9701 /S05	0,3 mm	0,9 mm
80 3MN			0,3 mm	0,9 mm
100 3MN	BALLUFF BAM000W	BALLUFF * BAW000J	1 mm	1,6 mm
125 3MN			0,8 mm	1,6 mm
160 3MN			0,8 mm	1,6 mm

* OR SIMILAR

200 MN / 250 MN / 320 MN / 380 MN

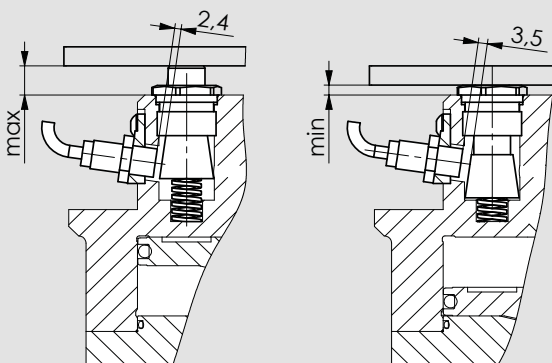

PROXIMITY BRACKET (OPTIONAL): 90166663

RECOMMENDED PROXIMITY:
BALLUFF M12X1 BAW0011 OR SIMILAR (NOT SUPPLIED)

ANALOGIC INDUCTIVE SENSOR for the linear jaw stroke control (optional)

When the jaws are in the maximum open position (R1 max) the sensor must be adjusted so that between the inclined plane and the sensor is the space S1.

64 MN / 80 MN / 100 MN / 125 MN

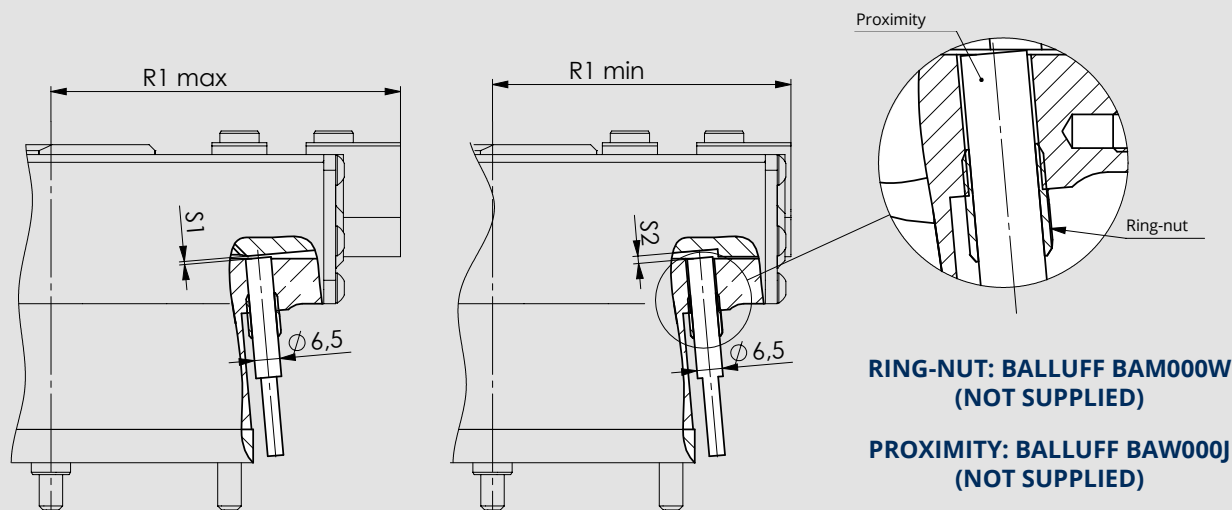

MODEL	S1 (±0,1)	S2 (±0,1)
64 3MN-L	0,9 mm	1,6 mm
80 3MN-L	0,9 mm	1,6 mm
100 3MN-L	0,8 mm	1,7 mm
125 3MN-L	0,7 mm	1,8 mm
125 3MN-N	1 mm	1,5 mm

160 MN / 200 MN / 250 MN / 320 MN / 380 MN

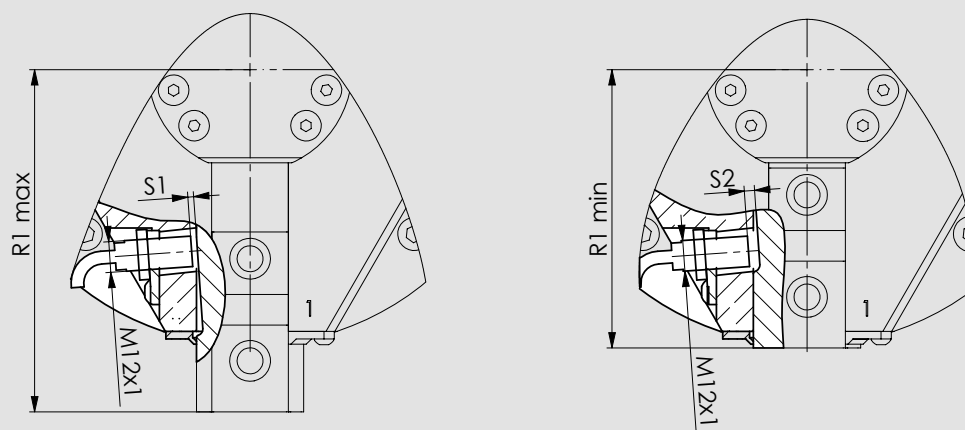

RECOMMENDED PROXIMITY:
BALLUFF M12X1 BAW0011 OR SIMILAR (NOT SUPPLIED)

MODEL	BRACKET ID.N. (OPTIONAL)	S1 [±0,1]	S2 [±0,1]
160 3MN-L	90166663	1,9 mm	4,1 mm
160 3MN-N	90166663	2,5 mm	3,6 mm
200 3MN-L	90167563	2,2 mm	3,9 mm
200 3MN-N	90166663	2 mm	4 mm
250 3MN-L	90167563	2 mm	4,1 mm
250 3MN-N	90166663	1,8 mm	4,2 mm
320 3MN-L	90167563	2 mm	4,1 mm
320 3MN-N	90167563	2,3 mm	3,8 mm
380 3MN-L	90167563	1,7 mm	4,3 mm
380 3MN-N	90167563	2,1 mm	3,9 mm

Pneumatic valve (optional)

open/close (stroke control) jaws

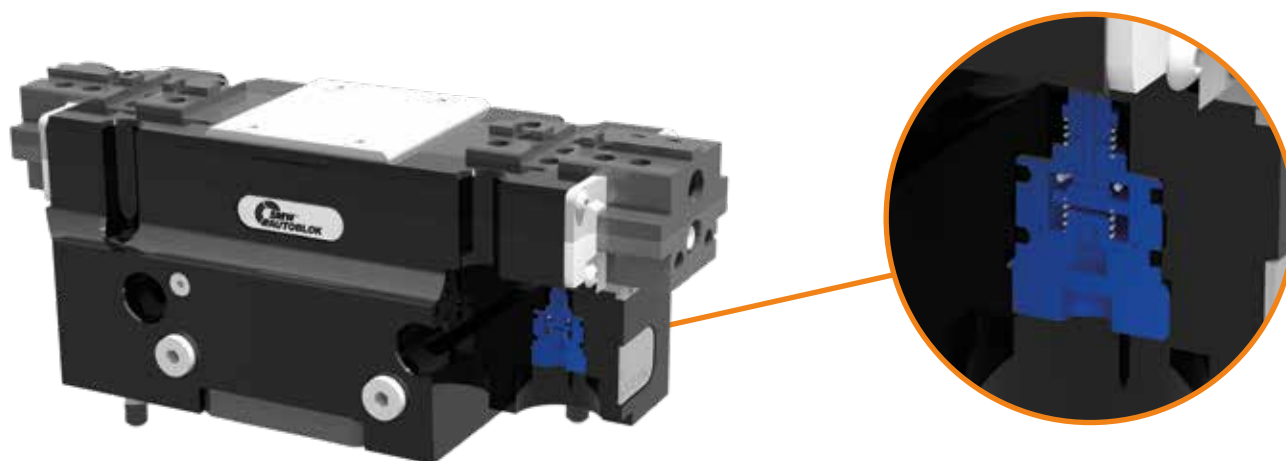

The pneumatic open/close stroke control valve signals the locking jaws end-of-stroke positions, both in fully open and fully closed positions.

The valve needs a pneumatic line with **filtered and lubricated air and a pressure of 0,5-1 bar.**

- when the locking jaws are in one of the end stroke position (fully open or closed), the valve is open causing a pressure drop in the pneumatic line or the beginning of an air flow.
- when the locking jaws are in the working stroke, the valve is closed and there is no pressure drop in the pneumatic line and there no air flow.

SMW-AUTOBLOK Id.No. VALVE	GRIPPERS MODEL
90901163	PP - PL 125
90901763	PP - PL 160
97902204	PP - PL 200
97901801	PP - PL 250
90901763	PL 320-380 (RR)

SMW-AUTOBLOK ID.No. VALVE	GRIPPERS MODEL
90902283	3MN 200-250-320-380

3PXS

3 jaws self-centering grippers Ø64-80-100

ALUMINIUM

Pneumatics



Technical features

- Aluminium body to contain the gripper weight
- Functional parts heat-treated for high precision and long life
- Jaws with calibrated bushings
- Protection class IP40
- Highest rigidity and Repeatability: 0,01 mm
- Prepared for Air purge

OPTIONAL:

- Spring workstop
- Inductive/Analogic stroke control sensor ON/OFF or linear
- Magnetic stroke control sensor ON/OFF or linear

Applications /Customer benefits

- Compact and light design
- O.D. and I.D. (also with springs versions)
- Interchangeable with most existing universal grippers

Standard equipment

Grippers without fingers and without sensors.
All screws for the double mounting, all centering bushings and all interface OR included.

SMW-Autoblok Type	Id. No.	Clamping force (daN) at 6 bar	Spring force min. (daN)	U (mm) jaw stroke	Air volume (cm ³)	Pressure (bar) min./max.	Closing/Opening time (s) at 6 bar	Weight (Kg)	Workpiece weight recommended (Kg)	e (mm) min./max.	R1 (mm) min./max.	R2 (mm) min./max.
3PXS-N 64	77920407	130	----	3	19,5	2/8	0,03/0,03	0,5	6,5	17,5/20,5	39/42	13,5/16,5
3PXS-NSE 64	77920507	160	30	3	36	4/6,5	0,05/0,03	0,6	6,5	17,5/20,5	39/42	13,5/16,5
3PXS-NSI 64	77920607	179	30	3	38,5	4/6,5	0,03/0,05	0,6	6,5	17,5/20,5	39/42	13,5/16,5
3PXS-L 64	77920107	63	----	6	19,5	2/8	0,03/0,03	0,5	3,0	17,5/23,5	36/42	13,5/19,5
3PXS-LSE 64	77920207	78	15	6	36	4/6,5	0,05/0,03	0,6	3,0	17,5/23,5	36/42	13,5/19,5
3PXS-LSI 64	77920307	85	15	6	38,5	4/6,5	0,03/0,05	0,6	3,0	17,5/23,5	36/42	13,5/19,5
3PXS-N 80	77920409	235	----	4	45,5	2/8	0,05/0,05	0,8	11,5	22/26	47,5/51,5	17/21
3PXS-NSE 80	77920509	305	70	4	78,5	4/6,5	0,06/0,04	1	11,5	22/26	47,5/51,5	17/21
3PXS-NSI 80	77920609	327	70	4	81,5	4/6,5	0,04/0,06	1	11,5	22/26	47,5/51,5	17/21
3PXS-L 80	77920109	110	----	8	45,5	2/8	0,05/0,05	0,8	5,5	22/30	43,5/51,5	17/25
3PXS-LSE 80	77920209	140	30	8	78,5	4/6,5	0,06/0,04	1	5,5	22/30	43,5/51,5	17/25
3PXS-LSI 80	77920309	150	30	8	81,5	4/6,5	0,04/0,06	1	5,5	22/30	43,5/51,5	17/25
3PXS-N 100	77920411	410	----	5	94,5	2/8	0,12/0,12	1,7	20,0	27,5/32,5	59/64	21,5/26,5
3PXS-NSE 100	77920511	545	135	5	171	4/6,5	0,22/0,12	2	20,0	27,5/32,5	59/64	21,5/26,5
3PXS-NSI 100	77920611	573	135	5	176	4/6,5	0,12/0,22	2	20,0	27,5/32,5	59/64	21,5/26,5
3PXS-L 100	77920111	195	----	10	94,5	2/8	0,12/0,12	1,7	9,5	27,5/37,5	54/64	21,5/31,5
3PXS-LSE 100	77920211	260	65	10	171	4/6,5	0,22/0,12	2	9,5	27,5/37,5	54/64	21,5/31,5
3PXS-LSI 100	77920311	273	65	10	176	4/6,5	0,12/0,22	2	9,5	27,5/37,5	54/64	21,5/31,5

Note:

3PXS-N: Normal stroke 3PXS-L: Long stroke 3PXS-NS: Normal stroke with springs 3PXS-LS: Long stroke with springs 3PXS-..E/I: OD / ID Clamping

64

3PXS

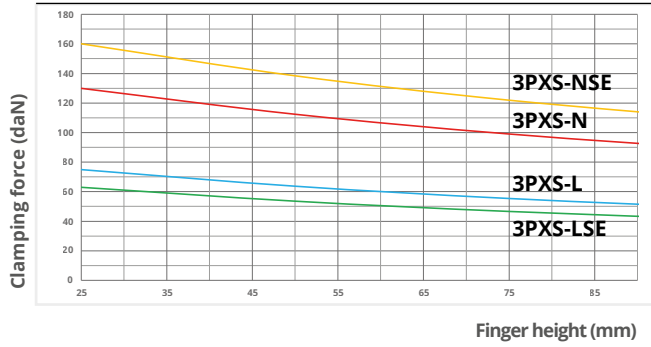

Clamping force calculated at **6 bar**.

Max. recommended fingers height: **90 mm**

Max. Fingers weight: **0,4 Kg**

For I.D. clamping consider **+10%** of the clamping force shown in the diagram.

Use connecting screws **class 12.9**

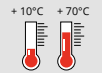
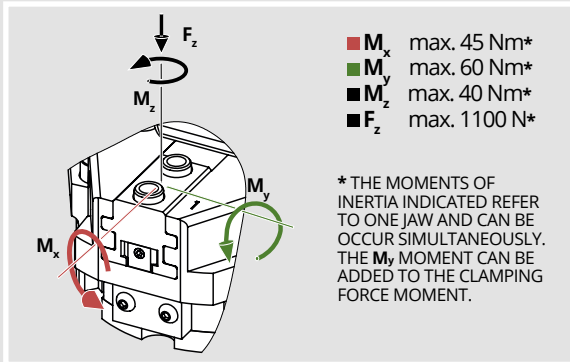

maximum allowed temperature using proximities is **60°C**

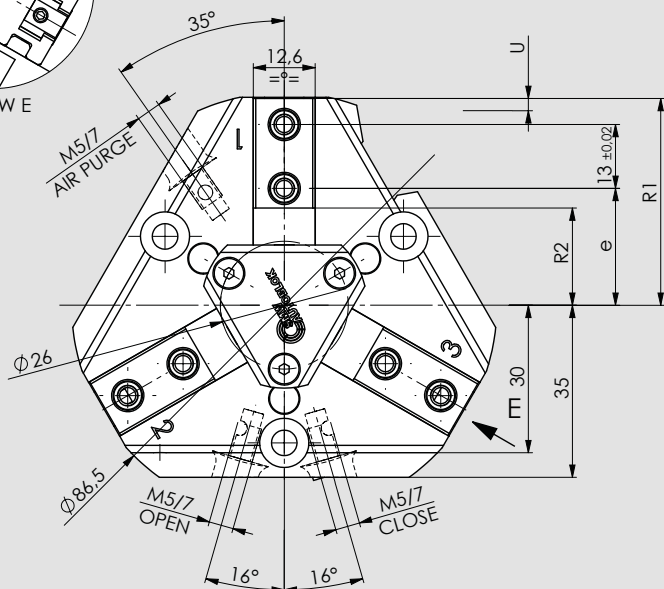
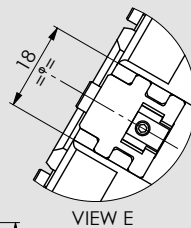
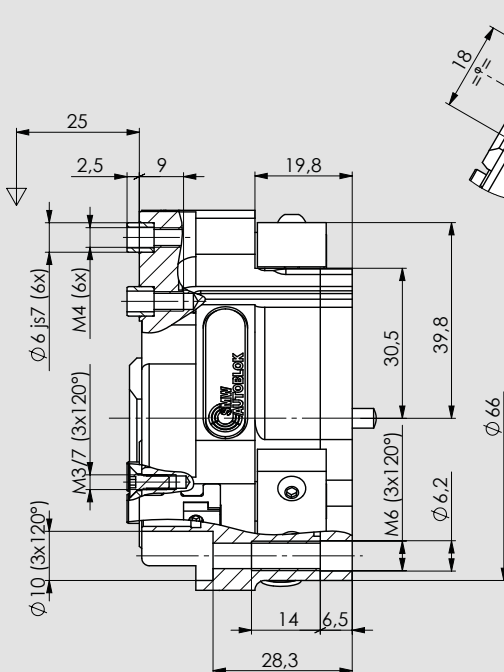
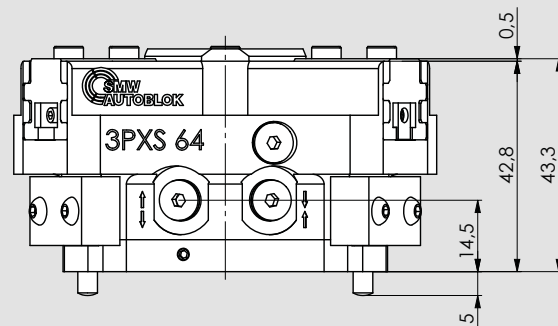
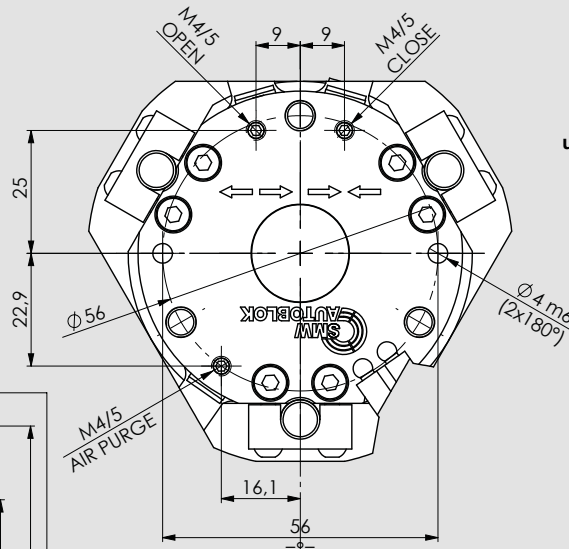
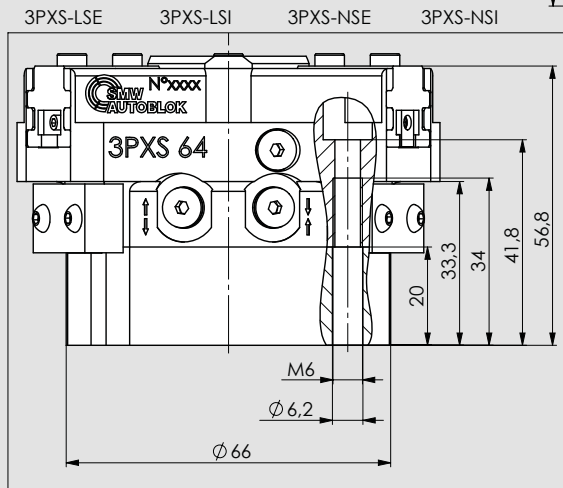

80

3PXS

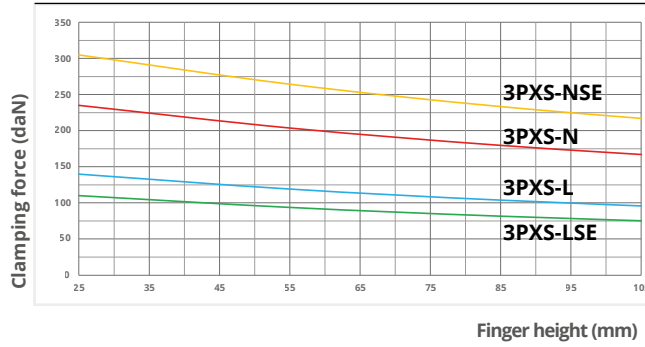

Clamping force calculated at **6 bar**.
 Max. recommended fingers height: **105 mm**
 Max. Fingers weight: **0,6 Kg**
 For I.D. clamping consider **+7%** of the clamping force shown in the diagram.
 Use connecting screws **class 12.9**

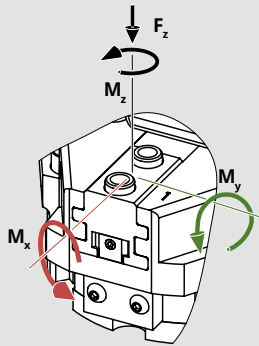

- M_x max. 60 Nm*
- M_y max. 95 Nm*
- M_z max. 55 Nm*
- F_z max. 1550 N*

* THE MOMENTS OF INERTIA INDICATED REFER TO ONE JAW AND CAN BE OCCUR SIMULTANEOUSLY. THE M_y MOMENT CAN BE ADDED TO THE CLAMPING FORCE MOMENT.

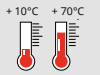

maximum allowed temperature using proximities is **60°C**

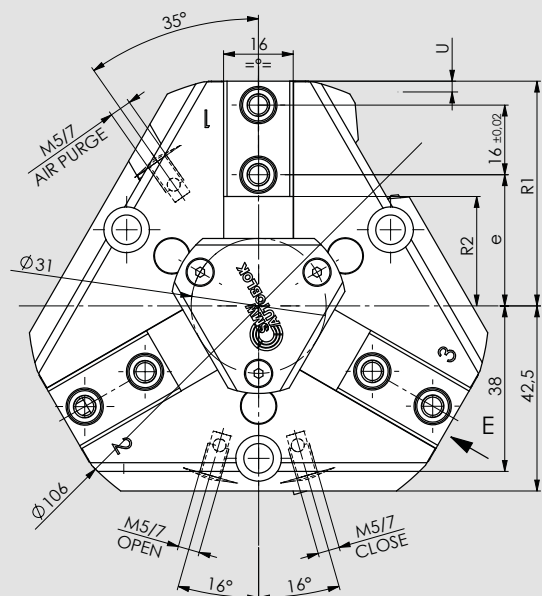
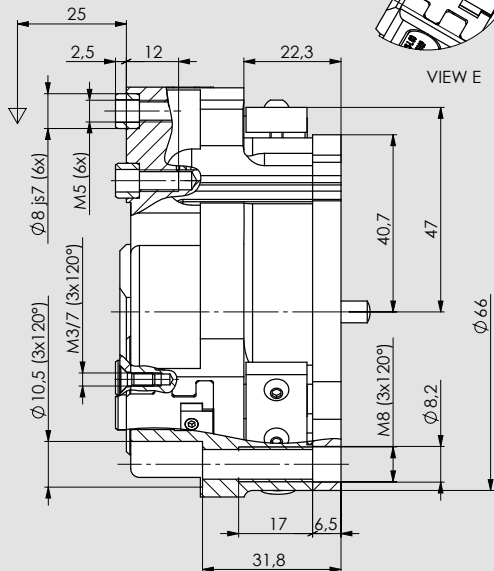
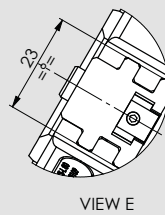
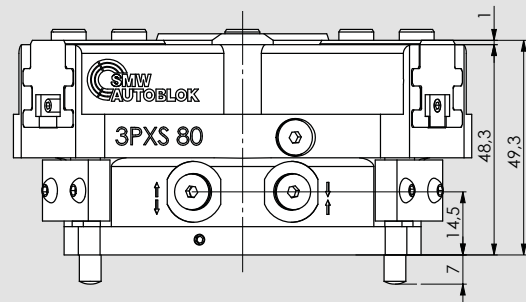
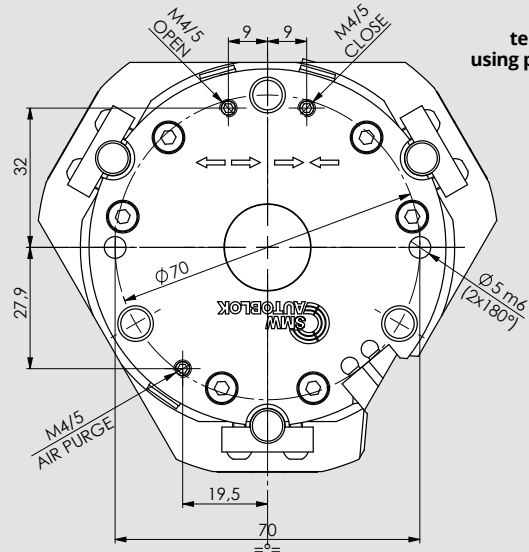
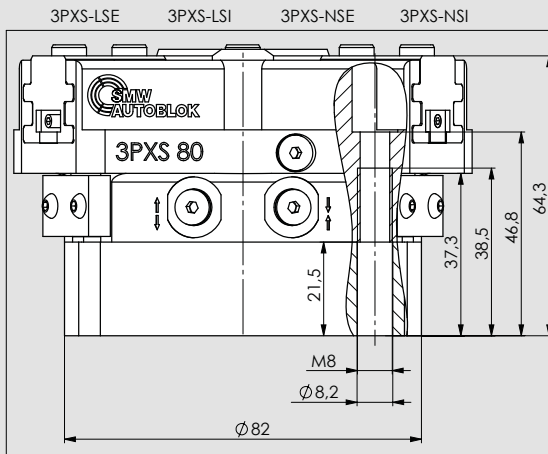

100

3PXS

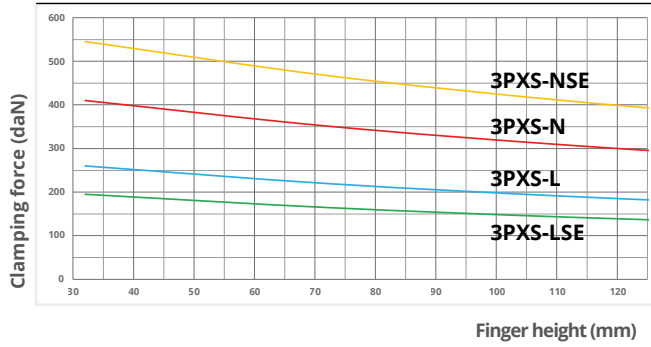

Clamping force calculated at **6 bar**.

Max. recommended fingers height: **125 mm**

Max. Fingers weight: **1,1 Kg**

For I.D. clamping consider **+5%** of the clamping force shown in the diagram.

Use connecting screws **class 12.9**

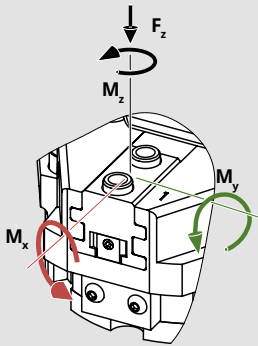

- M_x max. 85 Nm*
- M_y max. 115 Nm*
- M_z max. 70 Nm*
- F_z max. 2100 N*

* THE MOMENTS OF INERTIA INDICATED REFER TO ONE JAW AND CAN BE OCCUR SIMULTANEOUSLY. THE M_y MOMENT CAN BE ADDED TO THE CLAMPING FORCE MOMENT.

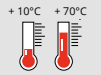

maximum allowed temperature using proximities is **60°C**

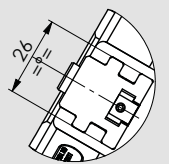
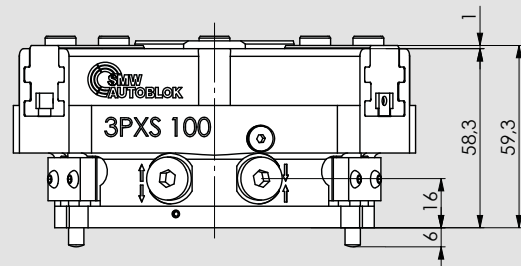
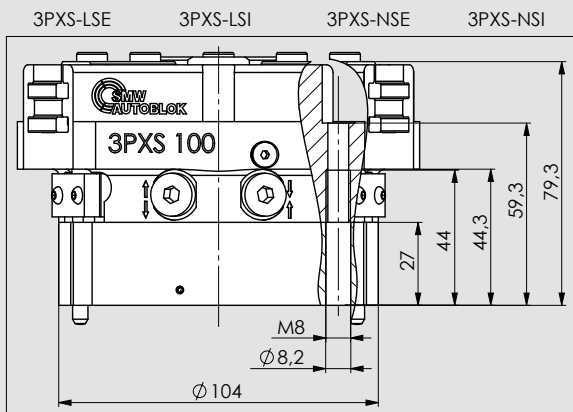
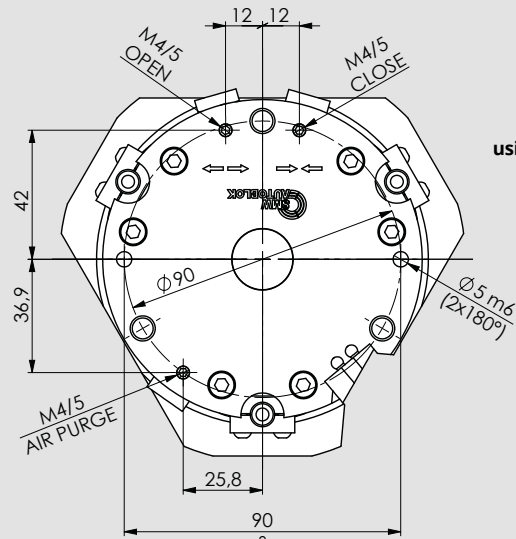

VIEW E

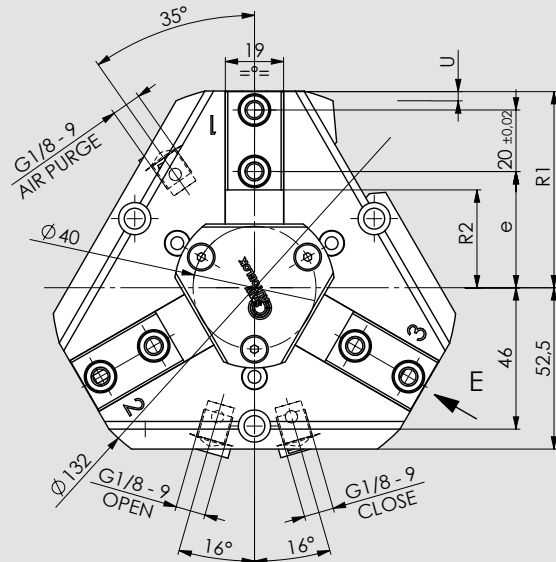
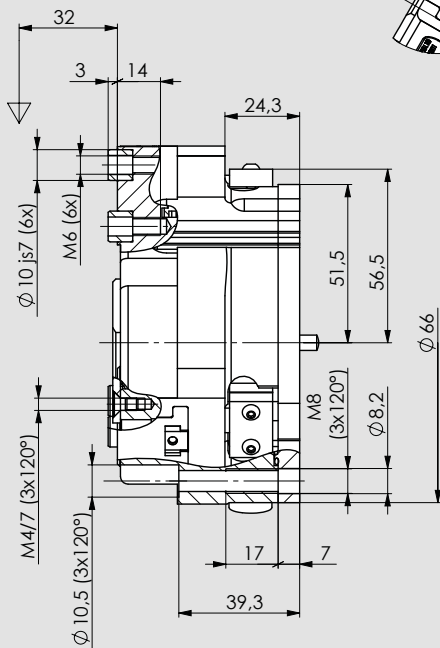

3PXM

3 jaws self-centering grippers Ø125-160-200

ALUMINIUM

Pneumatics - Protected



Technical features

- Aluminium body to contain the gripper weight
- Functional parts heat-treated for high precision and long life
- Jaws with calibrated bushings
- Protection class IP64
- Highest rigidity and Repeatability: 0,02 mm
- Prepared for Air purge

OPTIONAL:

- Spring workstop
- Inductive/Analogic stroke control sensor ON/OFF or linear
- Magnetic stroke control sensor ON/OFF or linear

Applications /Customer benefits

- Compact and light design
- O.D. and I.D. (also with springs versions)
- Interchangeable with most existing universal grippers

Standard equipment

Grippers without fingers and without sensors.
All screws for the double mounting, all centering bushings and all interface OR included.

SMW-Autoblok Type	Id. No.	Clamping force (daN) at 6 bar	Spring force min. (daN)	U (mm) jaw stroke	Air volume (cm³)	Pressure (bar) min./max.	Closing/Opening time (s) at 6 bar	Weight (Kg)	Workpiece weight recommended (Kg)	e (mm) min./max.	R1 (mm) min./max.	R2 (mm) min./max.
3PXM-N 125	77920413	675	----	6	200,5	2/8	0,2/0,2	2,7	33,5	35/41	76/82	28/34
3PXM-NSE 125	77920513	945	270	6	357	4/6,5	0,32/0,17	3,3	33,5	35/41	76/82	28/34
3PXM-NSI 125	77920613	990	270	6	366,5	4/6,5	0,17/0,32	3,3	33,5	35/41	76/82	28/34
3PXM-L 125	77920113	320	----	13	200,5	2/8	0,2/0,2	2,7	16,0	35/48	69/82	28/41
3PXM-LSE 125	77920213	450	130	13	357	4/6,5	0,32/0,17	3,3	16,0	35/48	69/82	28/41
3PXM-LSI 125	77920313	470	130	13	366,5	4/6,5	0,17/0,32	3,3	16,0	35/48	69/82	28/41
3PXM-N 160	77920417	1270	----	8	480	2/8	0,44/0,44	5,2	63,5	45/53	96,5/104,5	36/44
3PXM-NSE 160	77920517	1750	480	8	833	4/6,5	0,66/0,36	6,5	63,5	45/53	96,5/104,5	36/44
3PXM-NSI 160	77920617	1800	480	8	847,5	4/6,5	0,36/0,66	6,5	63,5	45/53	96,5/104,5	36/44
3PXM-L 160	77920117	600	----	16	480	2/8	0,44/0,44	5,2	30,0	45/61	88,5/104,5	36/52
3PXM-LSE 160	77920217	830	230	16	833	4/6,5	0,66/0,36	6,5	30,0	45/61	88,5/104,5	36/52
3PXM-LSI 160	77920317	855	230	16	847,5	4/6,5	0,36/0,66	6,5	30,0	45/61	88,5/104,5	36/52
3PXM-N 200	77920421	1220	----	14	866	2/8	1,05/1,05	10,1	60,0	49/63	116/130	39,5/53,5
3PXM-NSE 200	77920521	1630	410	14	1476,5	4/6,5	1,38/0,9	12,2	60,0	49/63	116/130	39,5/53,5
3PXM-NSI 200	77920621	1680	410	14	1502	4/6,5	0,9/1,38	12,2	60,0	49/63	116/130	39,5/53,5
3PXM-L 200	77920121	810	----	25	866	2/8	1,05/1,05	10,1	40,5	49/74	105/130	39,5/64,5
3PXM-LSE 200	77920221	1085	275	25	1476,5	4/6,5	1,38/0,9	12,2	40,5	49/74	105/130	39,5/64,5
3PXM-LSI 200	77920321	1120	275	25	1502	4/6,5	0,9/1,38	12,2	40,5	49/74	105/130	39,5/64,5

Note:

3PXM-N: Normal stroke 3PXM-L: Long stroke 3PXM-NS: Normal stroke with springs 3PXM-LS: Long stroke with springs 3PXM-..E/I: OD / ID Clamping

125

3PXM

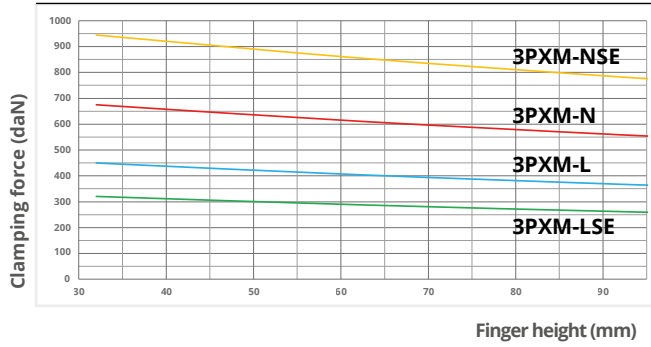

Clamping force calculated at **6 bar**.
 Max. recommended fingers height: **95 mm**
 Max. Fingers weight: **2 Kg**
 For I.D. clamping consider **+5%** of the clamping force shown in the diagram.
 Use connecting screws **class 12.9**

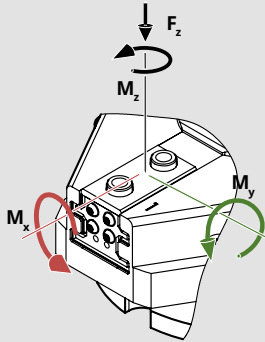

- M_x max. 120 Nm*
- M_y max. 145 Nm*
- M_z max. 100 Nm*
- F_z max. 2800 N*

* THE MOMENTS OF INERTIA INDICATED REFER TO ONE JAW AND CAN BE OCCUR SIMULTANEOUSLY. THE M_y MOMENT CAN BE ADDED TO THE CLAMPING FORCE MOMENT.

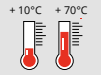

maximum allowed temperature using proximities is **60°C**

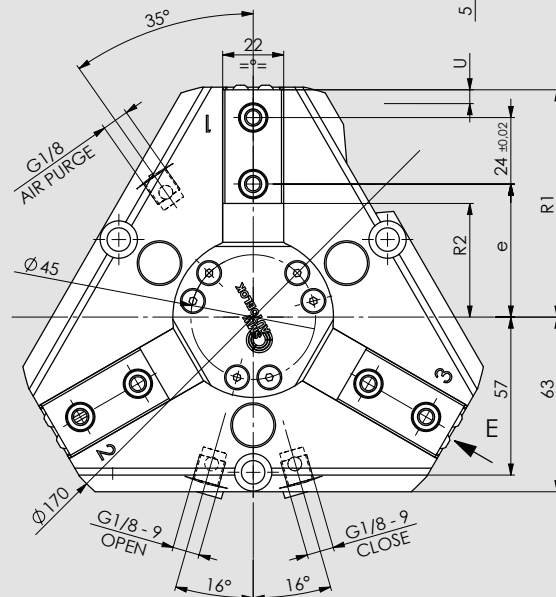
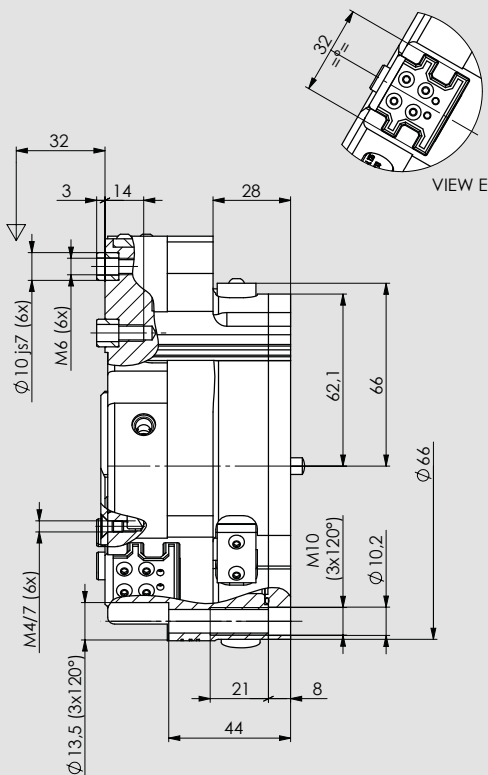
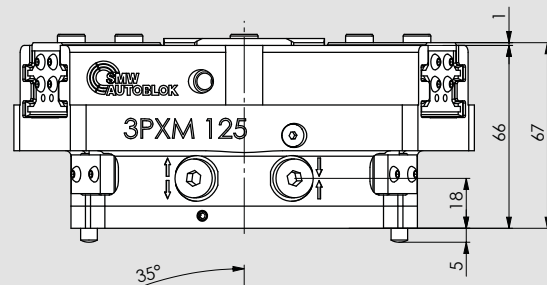
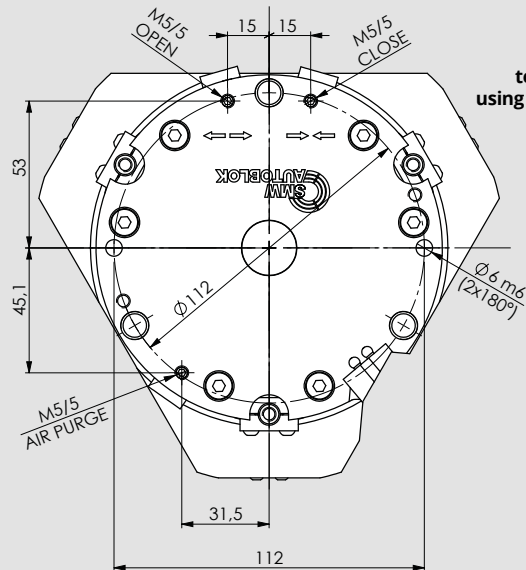
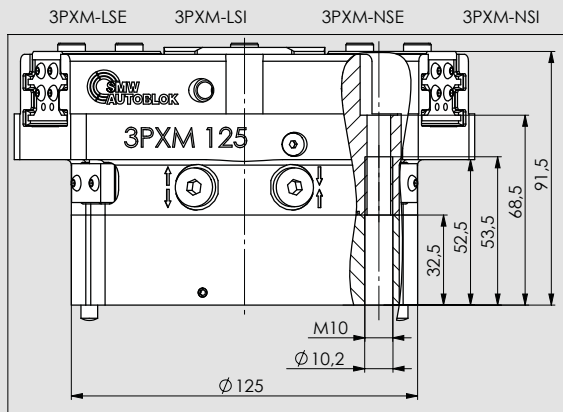

160

3PXM

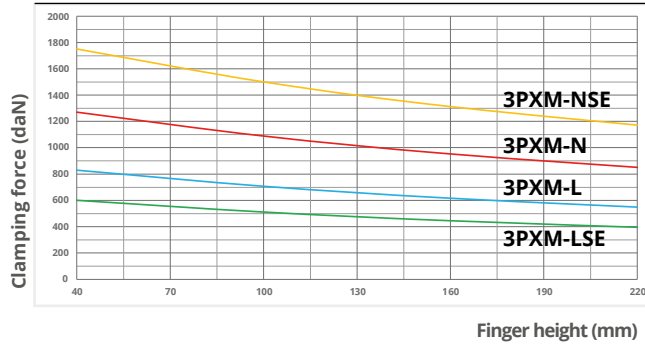

Clamping force calculated at **6 bar**.
 Max. recommended fingers height: **220 mm**
 Max. Fingers weight: **3,5 Kg**
 For I.D. clamping consider **+3%** of the clamping force shown in the diagram.
 Use connecting screws **class 12.9**

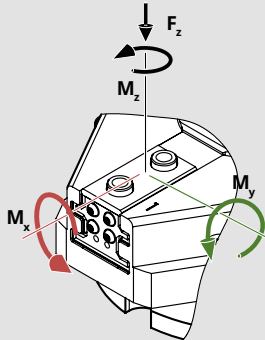

- M_x max. 170 Nm*
- M_y max. 180 Nm*
- M_z max. 140 Nm*
- F_z max. 4400 N*

* THE MOMENTS OF INERTIA INDICATED REFER TO ONE JAW AND CAN BE OCCUR SIMULTANEOUSLY. THE M_y MOMENT CAN BE ADDED TO THE CLAMPING FORCE MOMENT.

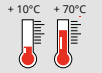

maximum allowed temperature using proximities is **60°C**

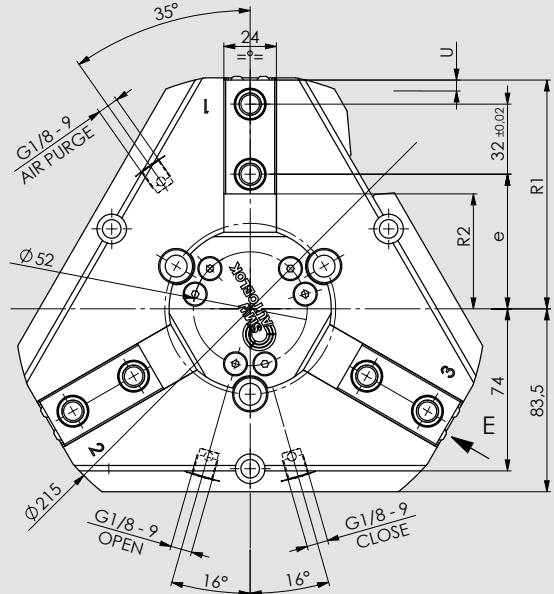
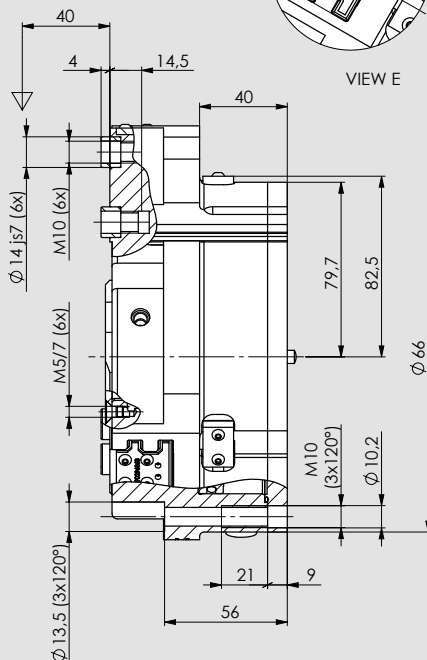
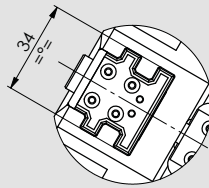
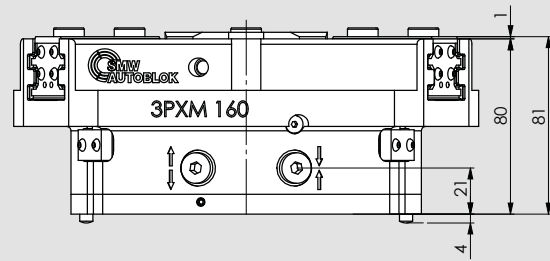
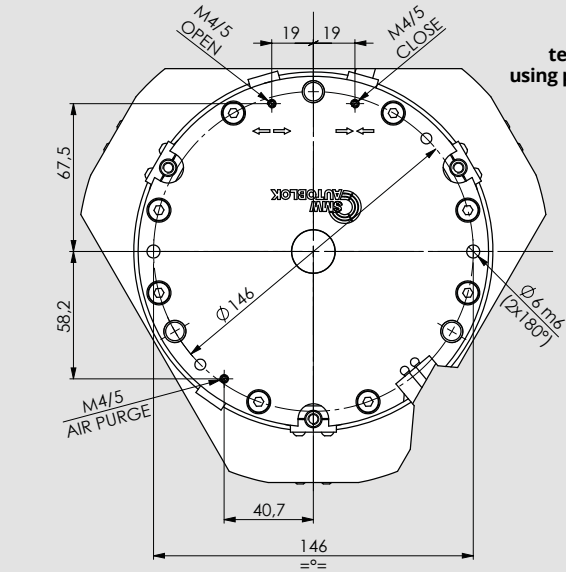
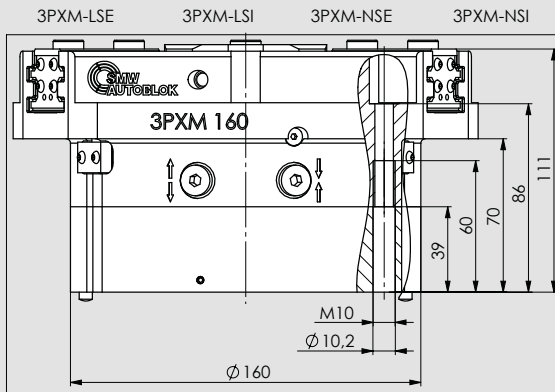

200

3PXM

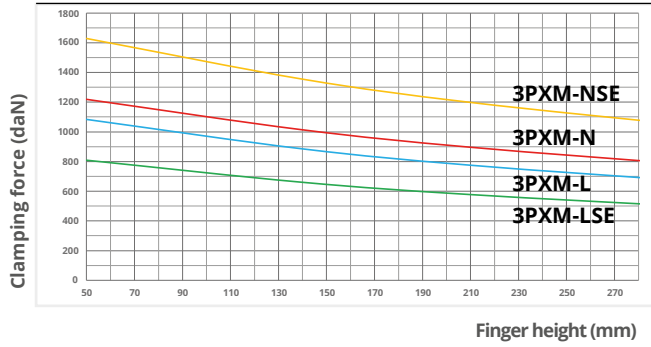

Clamping force calculated at **6 bar**.

Max. recommended fingers height: **280 mm**

Max. Fingers weight: **6,5 Kg**

For I.D. clamping consider **+3%** of the clamping force shown in the diagram.

Use connecting screws **class 12.9**

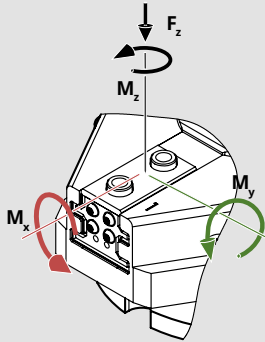

- M_x max. 180 Nm*
- M_y max. 200 Nm*
- M_z max. 155 Nm*
- F_z max. 5500 N*

* THE MOMENTS OF INERTIA INDICATED REFER TO ONE JAW AND CAN BE OCCUR SIMULTANEOUSLY. THE M_y MOMENT CAN BE ADDED TO THE CLAMPING FORCE MOMENT.

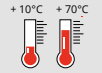

maximum allowed temperature using proximities is **60°C**

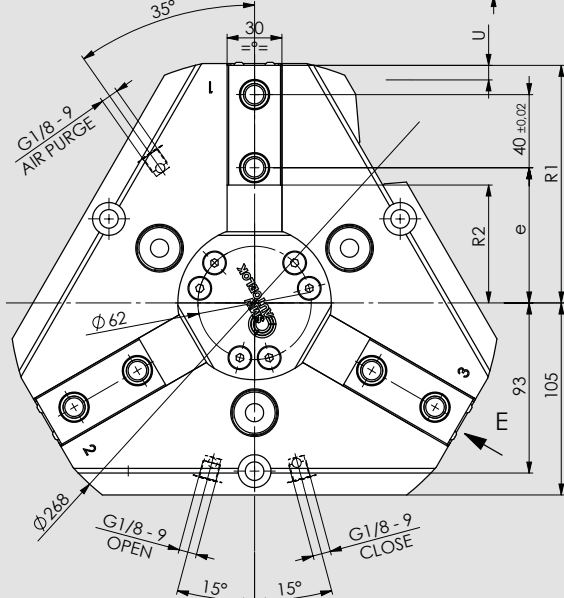
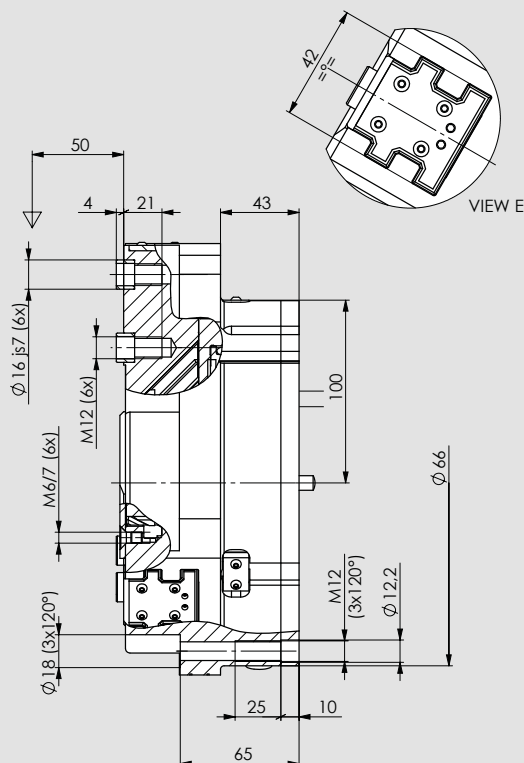
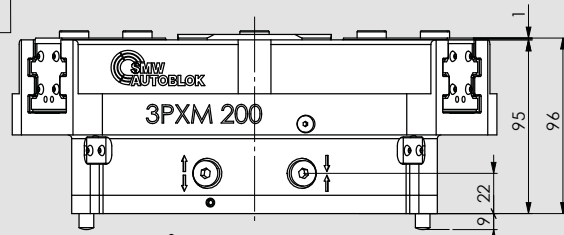
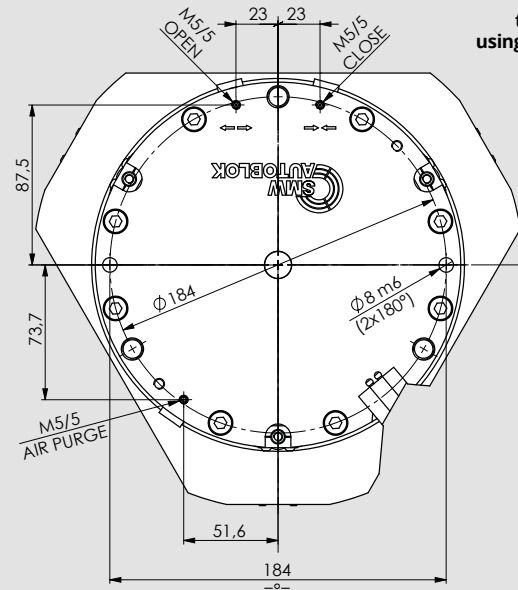
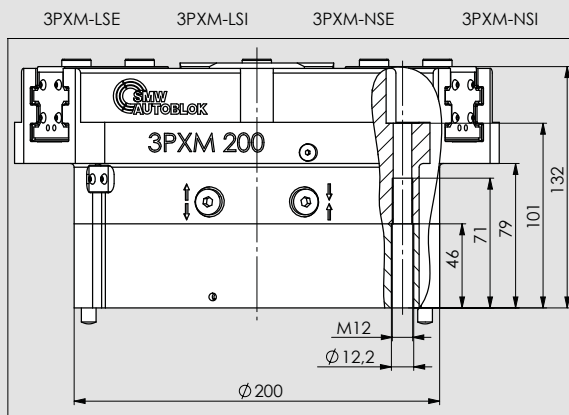

3PXL

3 jaws self-centering grippers Ø250

ALUMINIUM

Pneumatics - Protected



Technical features

- Aluminium body to contain the gripper weight
- Functional parts heat-treated for high precision and long life
- Jaws with calibrated bushings
- Protection class IP64
- Highest rigidity and repeatability: 0,04 mm
- Prepared for air purge

OPTIONAL:

- Spring workstop
- Inductive/Analogic stroke control sensor ON/OFF or linear
- Magnetic stroke control sensor ON/OFF or linear

Applications /Customer benefits

- Compact and light design
- O.D. and I.D. (also with springs versions)
- Interchangeable with most existing universal grippers

Standard equipment

Grippers without fingers and without sensors.
All screws for the double mounting, all centering bushings and all interface OR included.

SMW-Autoblok Type	Id. No.	Clamping force (daN) at 6 bar	Spring force min. (daN)	U (mm) jaw stroke	Air volume (cm³)	Pressure (bar) min./max.	Closing/Opening time (s) at 6 bar	Weight (Kg)	Workpiece weight recommended (Kg)	e (mm) min./max.	R1 (mm) min./max.	R2 (mm) min./max.
3PXL-N 250	77920426	1755	-----	17	1496,5	2/8	1,23/1,23	17	87,5	57/74	132,5/149,5	47/64
3PXL-NSE 250	77920526	2405	650	17	2571,5	4/6,5	2,05/1,08	21	87,5	57/74	132,5/149,5	47/64
3PXL-NSI 250	77920626	2480	650	17	2616,5	4/6,5	1,08/2,05	21	87,5	57/74	132,5/149,5	47/64
3PXL-L 250	77920126	1170	-----	30	1496,5	2/8	1,23/1,23	17	58,5	57/87	119,5/149,5	47/77
3PXL-LSE 250	77920226	1605	435	30	2571,5	4/6,5	2,05/1,08	21	58,5	57/87	119,5/149,5	47/77
3PXL-LSI 250	77920326	1655	435	30	2616,5	4/6,5	1,08/2,05	21	58,5	57/87	119,5/149,5	47/77

Note:

3PXL-N: Normal stroke 3PXL-L: Long stroke 3PXL-NS: Normal stroke with springs 3PXL-LS: Long stroke with springs 3PXL-..E/I: OD / ID Clamping

250

3PXL

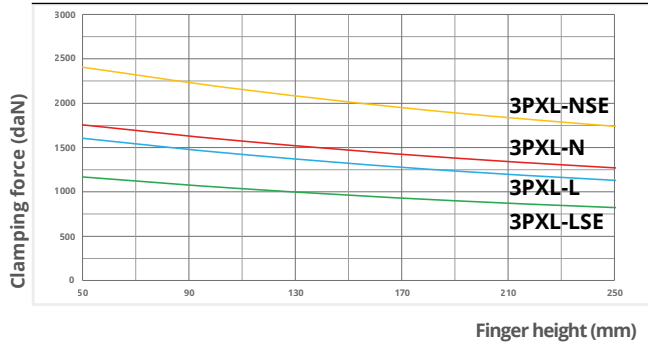

Clamping force calculated at **6 bar**.
 Max. recommended fingers height: **250 mm**
 Max. Fingers weight: **8,5 Kg**
 For I.D. clamping consider **+3%** of the clamping force shown in the diagram.
 Use connecting screws **class 12.9**

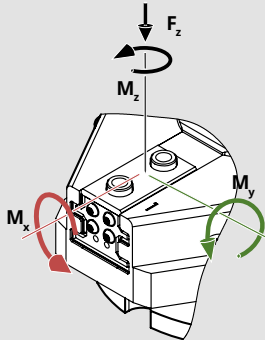

- M_x max. 265 Nm*
- M_y max. 255 Nm*
- M_z max. 190 Nm*
- F_z max. 6800 N*

* THE MOMENTS OF INERTIA INDICATED REFER TO ONE JAW AND CAN BE OCCUR SIMULTANEOUSLY. THE M_y MOMENT CAN BE ADDED TO THE CLAMPING FORCE MOMENT.

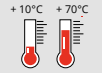

maximum allowed temperature using proximities is **60°C**

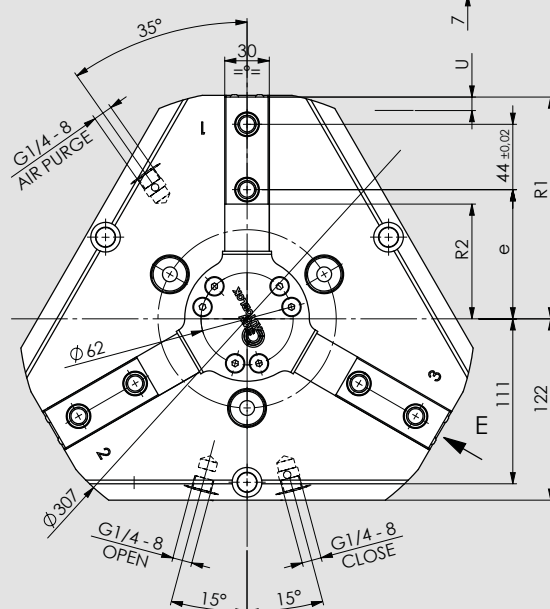
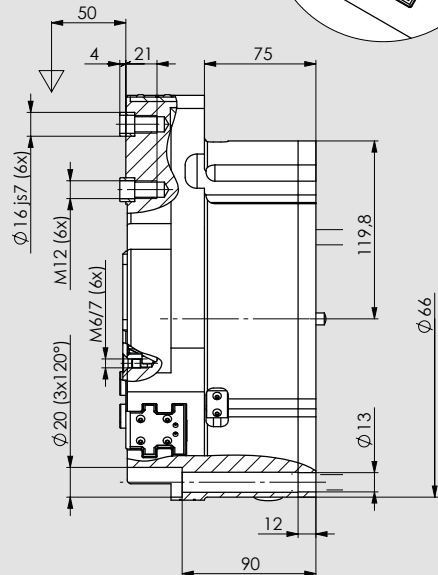
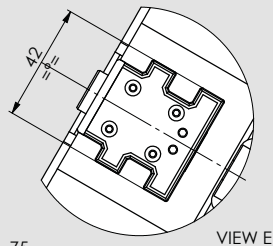
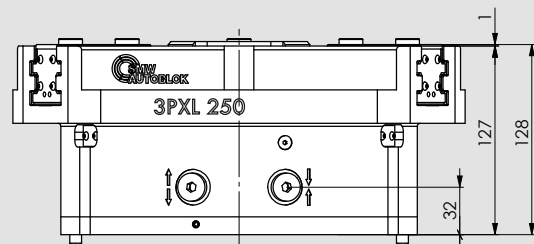
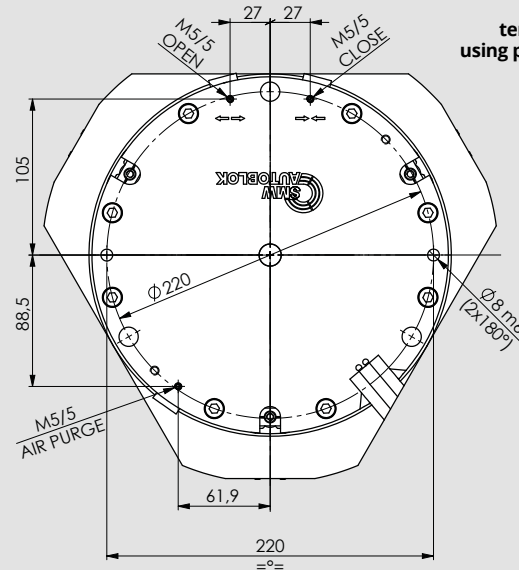
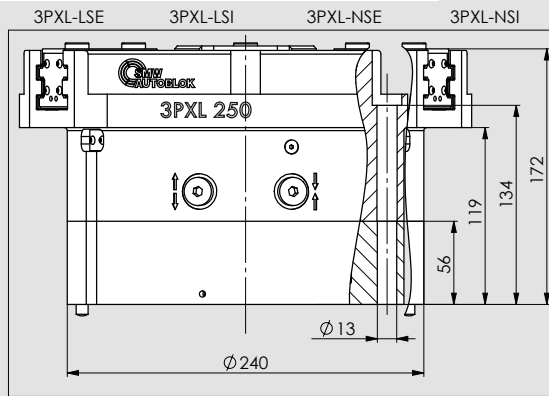

CLOSED ON/OFF

OPEN ON/OFF

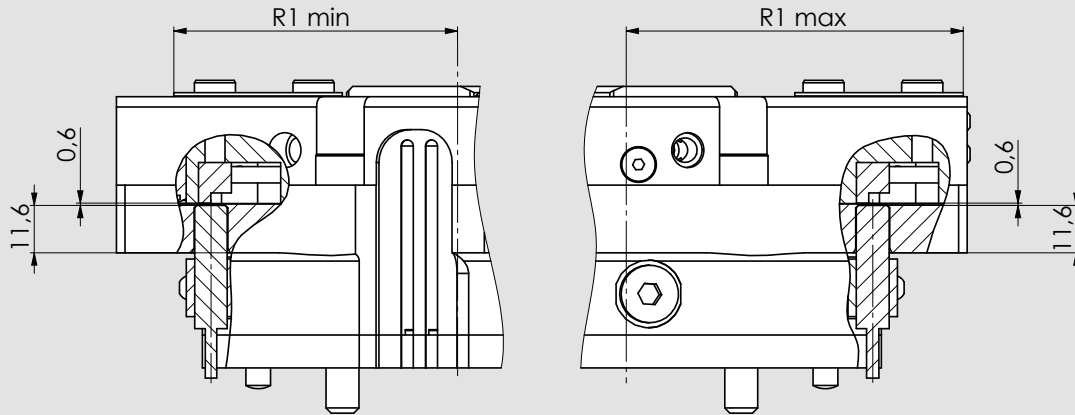

MOUNTED ON JAWS nr.2 and 3

SMW-AUTOBLOK Type	SENSOR Id.N. (*)
CYLINDRICAL SENSOR M8x1 L=30	0E012802

(*) Id.n. refers to n.1 sensor. For more details ask the data sheet.

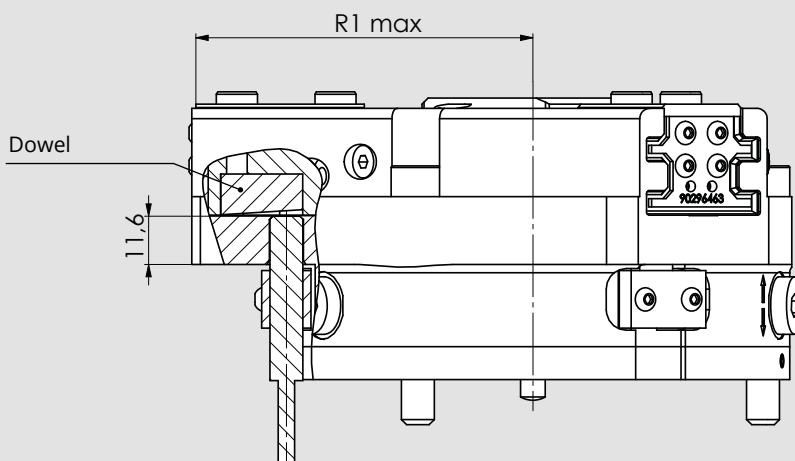

MOUNTED ON JAW nr.1

SMW-AUTOBLOK Type	SENSOR Id.N. (*)	DOWEL Id.N.
CYLINDRICAL SENSOR M8x1 L=40	0E012810	92262163

(*) For more details ask the data sheet.

SENSORS for 3PXS 3PXM 3PXL GRIPPERS

MAGNETIC ON/OFF SENSOR

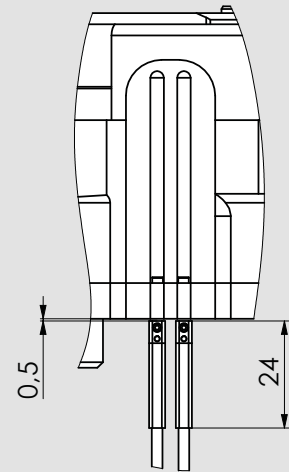
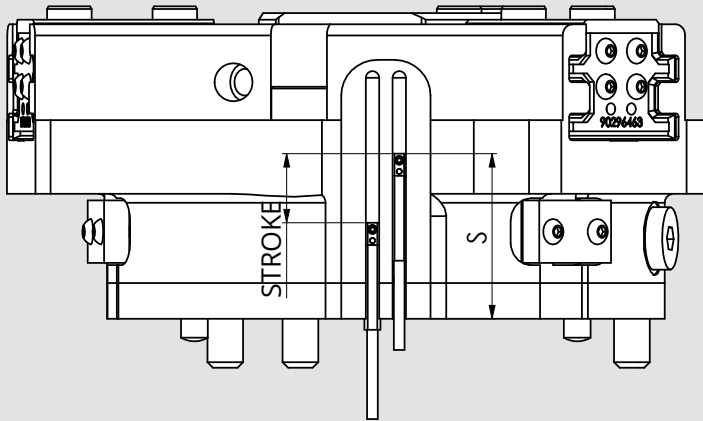

SMW-AUTOBLOK Type

MAGNETIC SENSOR Balluff**

SENSOR Id.N. (*)

BMF00P0

(*) Id.n. refers to n.1 sensor. For more details ask the data sheet.
 (**) or similars

MAGNETIC LINEAR SENSOR

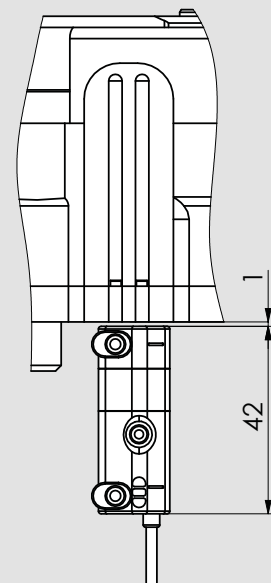
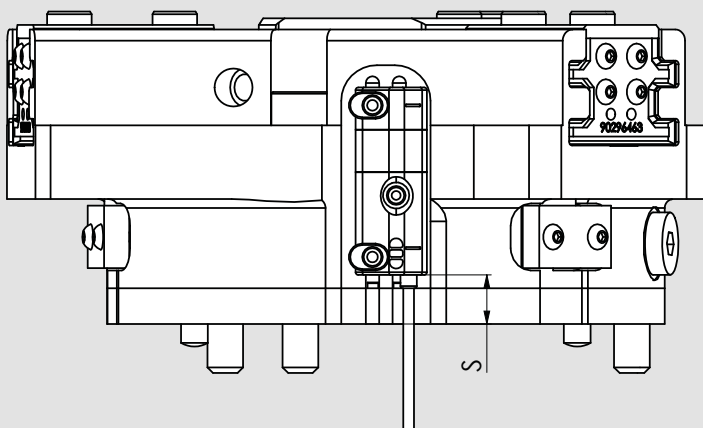

SMW-AUTOBLOK Type

ANALOGIC MAGNETIC SENSOR Balluff**

SENSOR Id.N. (*)

BMP0008

(*) For more details ask the data sheet.
 (**) or similars

ALUMINIUM FINGERS for grippers

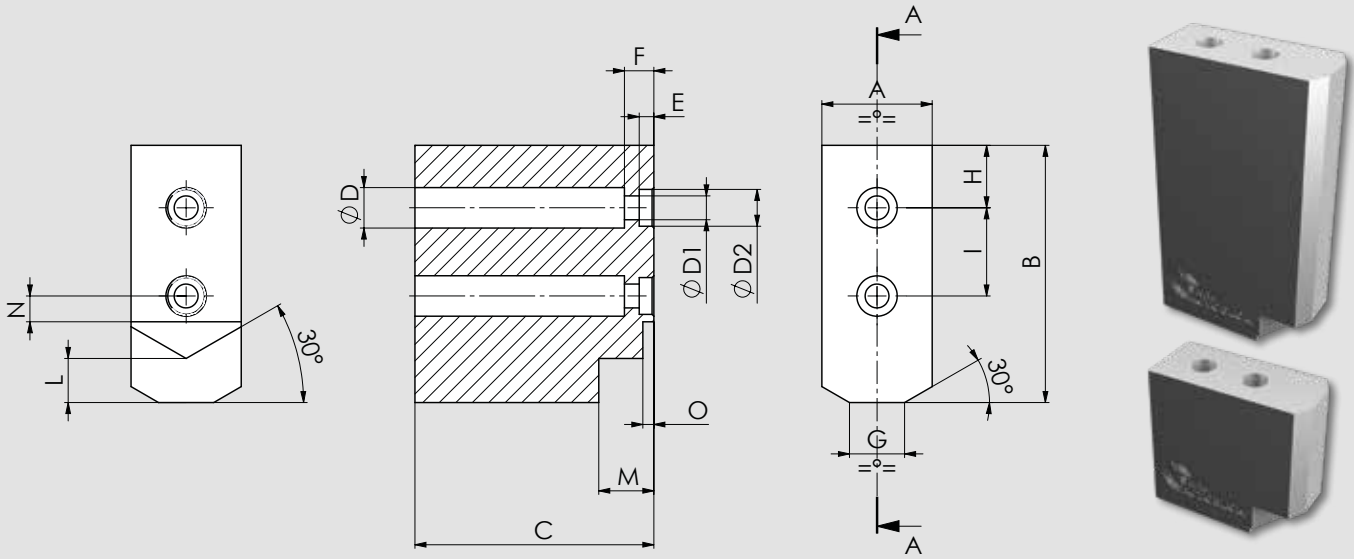

GRIPPER SIZE	ID. NO.	MAT.	A	B	C	Ø D	Ø D1	Ø D2	E	F	G	H	I	L	M	N	O	CLAMPING RANGE		WEIGHT (kg)	
																		NORMAL STROKE	LONG STROKE		
PL 64 2PXS 64	92720663	AL	20	40	35	8	4,5	6	3,5	6	1	11	13	8	11	4	3		0 - 2,5	0 - 8,5	0,057
	64				0,108																
3MN 64 3PXS 64	92720663	AL	20	40	35	8	4,5	6	3,5	6	1	11	13	8	11	4	3		3 - 9	3 - 15	0,057
	64				0,108																
PL 80 2PXS 80	92720863	AL	25	45	45	9	5,5	8	3,5	7	6	10	16	8	11	5	3		0 - 7	0 - 15	0,108
	80				0,2																
3MN 80 3PXS 80	92720863	AL	25	45	45	9	5,5	8	3,5	7	6	10	16	8	11	5	3		6 - 14	6 - 22	0,108
	80				0,2																
PL 100 2PXS 100	92721063	AL	25	55	55	11	6,5	10	4	8	10	12	20	8	11	6	3		1 - 11	1 - 21,5	0,16
	100				0,3																
3MN 100 3PXS 100	92721063	AL	25	55	55	11	6,5	10	4	8	10	12	20	8	11	6	3		9 - 19	9 - 29	0,16
	100				0,3																
2PXM 125	92721263	AL	30	70	65	11	6,5	10	4	8	15	17	24	12	15	7	3		3 - 15,5	3 - 29,5	0,31
	125				0,61																
3MN 125 3PXM 125	92721263	AL	30	70	65	11	6,5	10	4	8	15	17	24	12	15	7	3		12 - 24	12 - 38	0,31
	125				0,61																
2PXM 160	92721663	AL	30	80	80	17	11	14	5	11	15	11	32	10	14	9	4		3 - 19	3 - 36,5	0,4
	160				0,81																
3MN 160 3PXM 160	92721663	AL	30	80	80	17	11	14	5	11	15	11	32	10	14	9	4		16 - 32	16 - 48	0,4
	160				0,81																
2PXM 200	92722063	AL	40	100	100	20	13	16	5	13	20	20	40	15	18	9,5	4		0 - 25	0 - 46	0,87
	200				1,76																
3MN 200 3PXM 200	92722063	AL	40	100	100	20	13	16	5	13	20	20	40	15	18	9,5	4		18 - 46	18 - 68	0,87
	200				1,76																
2PXL 250	92722563	AL	40	120	120	20	13	16	5	13	20	26	44	15	18	10	4		0 - 28	0 - 53,5	1,3
	220				2,4																
3MN 250 3PXL 250	92722563	AL	40	120	120	20	13	16	5	13	20	26	44	15	18	10	4		14 - 48	14 - 74	1,3
	220				2,4																

7

PRS CONFIGURATIONS

204

PRS

Robot quick change systems.
Ø 55-85-110-160-240

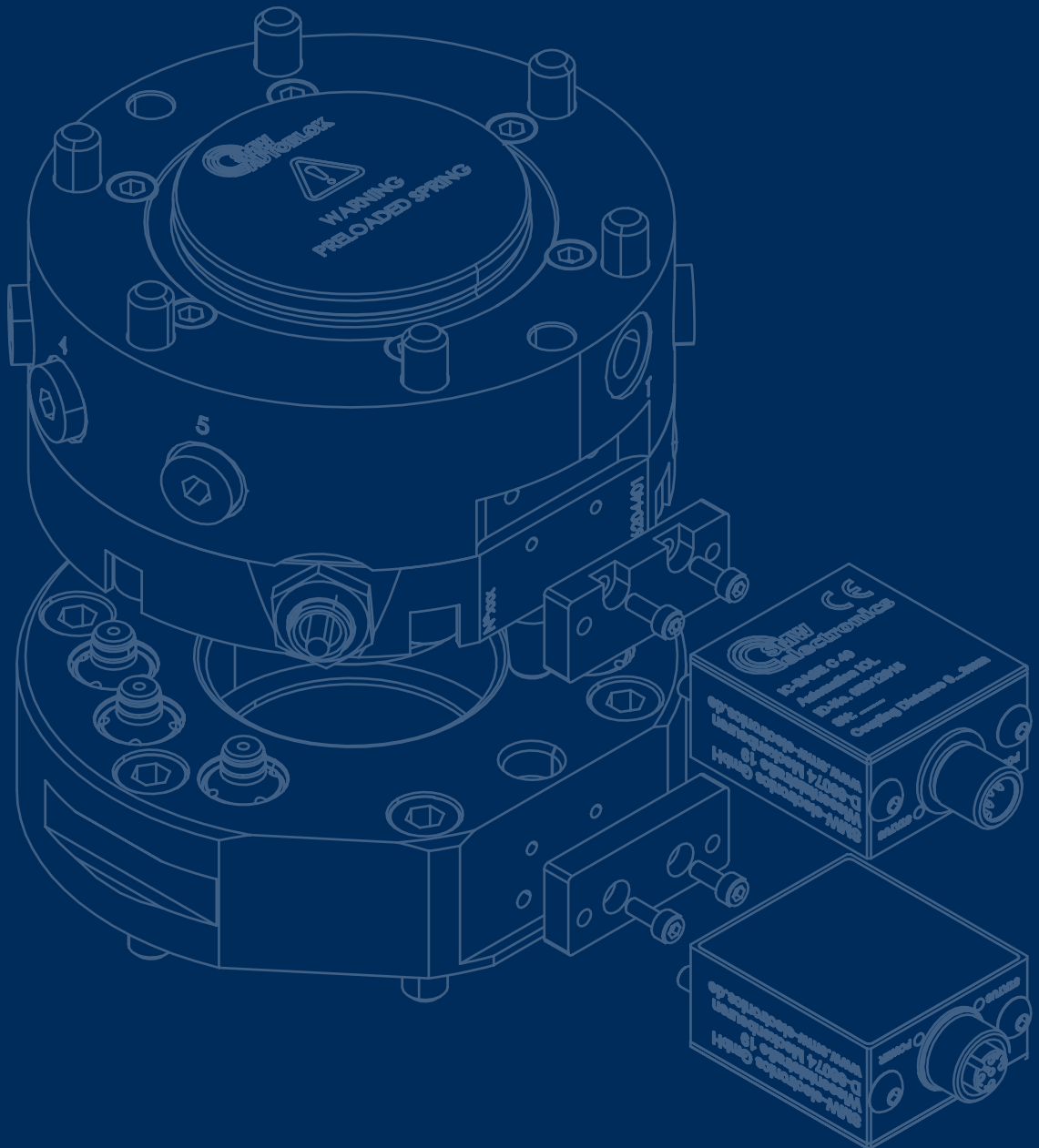

PRS

Robot quick change systems

CUSTOMER BENEFITS

- ▶ Quick and safe gripper change
- ▶ ISO flange
- ▶ Pneumatic drive
- ▶ Self-locking by spring tension (turbo)
- ▶ Wear-free and maintenance-free contactless transmission system for energy and signals (optional)
- ▶ Integrated interlock status query

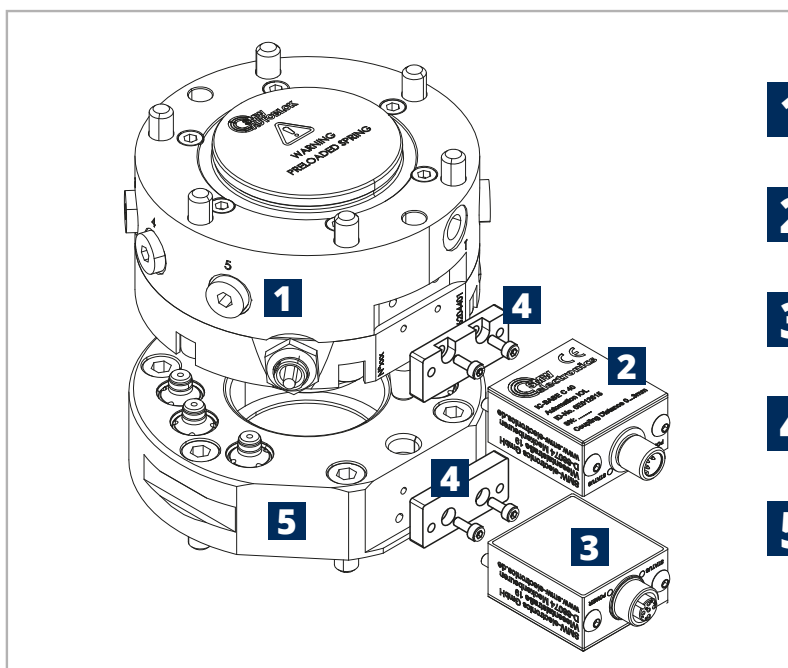

- 1** QUICK CHANGE MODULE ROBOT SIDE
- 2** CONNECTION MODULES / INDUCTIVE COUPLING BASE UNIT
- 3** CONNECTION MODULES / INDUCTIVE COUPLING REMOTE UNIT
- 4** MOUNTING KIT
- 5** QUICK CHANGE MODULE TOOL SIDE



SMW-Autoblok TYPE	Size					Id.n. without pallet	n. pneumatic connections		Stroke control: Inductive and analogic proximity-based	Pneumatic opening	Springs clamp + TURBO	Electric signal interface module (optional)
	55	85	110	160	240		6	7				
PRS	55					46204550						
		85				46204600						
			110			46204400						
				160		46204320						
					240	46204500						



CLAMPING EXAMPLE

Id.n. PRS	Max liftable weight	Repeatability 0,015 mm	Pull-down force		Pressure		Weight
			spring	spring + TURBO	open	TURBO	
46204550	20 kg	0,015	70 daN	340 daN	6 bar	6 bar	0,5 kg
46204600	50 kg	0,015	200 daN	1000 daN	6 bar	6 bar	1,3 kg
46204400	75 kg	0,015	250 daN	1400 daN	6 bar	6 bar	3 Kg
46204320	150 kg	0,015	400 daN	1900 daN	6 bar	6 bar	6 Kg
46204500	500 kg	0,015	1250 daN	7600 daN	6 bar	6 bar	16 Kg

FLANGE GROUP

for head changing 55 PRS

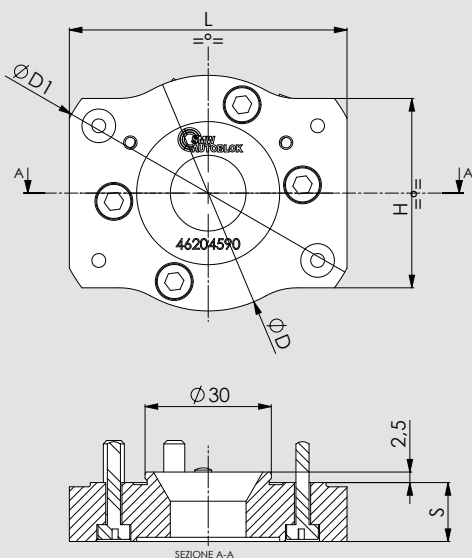

FLANGE KIT Id.No.	D	D1	S	H	L	WEIGHT kg	MONTABLE GRIPPERS TYPE
46204588 FLANGE KIT 55PRS/PL - 2PXS 64	62	62	14	/	58	0,11	PL 64 - 2PXS 64 *
46204590 FLANGE KIT 55PRS/PL - 2PXS 80	56	75	14	45	66	0,12	PL 80 - 2PXS 80 *
46204592 FLANGE KIT 55PRS/PL - 2PXS 100	56	93	14	55	82	0,17	PL 100 - 2PXS 100 *
46204594 FLANGE KIT 55PRS/3MN - 3PXS 64	68	68	14	/	/	0,14	3MN 64 - 3PXS 64 **
46204596 FLANGE KIT 55PRS/3MN - 3PXS 80	84	84	14	/	/	0,21	3MN 80 - 3PXS 80 **
46204598 FLANGE KIT 55PRS/3MN - 3PXS 100	104	104	14	/	/	0,33	3MN 100 - 3PXS 100 **

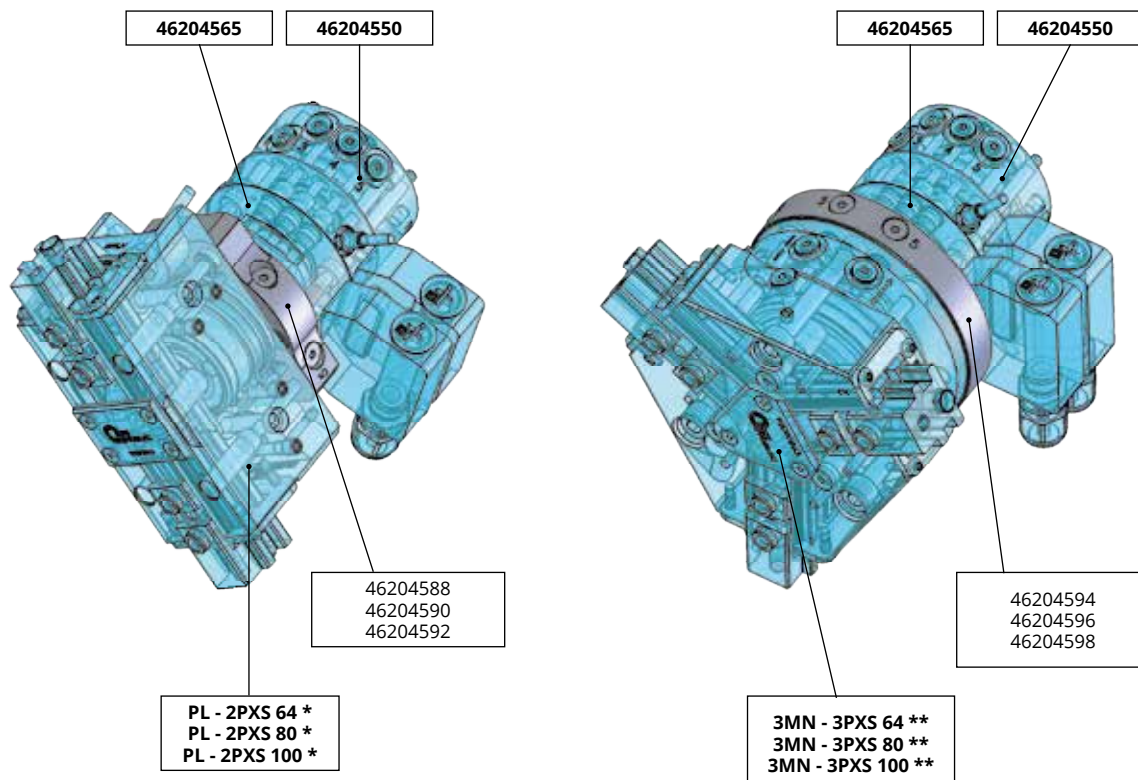

85 PRS PNEUMATIC HEAD CHANGING

- Pneumatic operation
- Spring clamping + TURBO

Function

Automatic head/gripper changing system for robots

Technical features

- Body and internal mechanism case-hardened for higher rigidity and longer life
- Inductive and analogic proximity-based stroke control system (as standard)
- Pneumatic opening

- Spring clamp + TURBO
- Electric signal interface module (optional)
- n.6 pneumatic connectors for media trasmission between the changing unit and the gripper mounting on it.
- hydraulic connectors are not expected

Model	Id.n. (without pallet)	Max liftable weight	Repeatability	pneumatic connections n.	Pull down force		Pressure		Weight
					spring	spring+TURBO	open	TURBO	
85 PRS	46204600	50 kg	0,015 mm	6	2 kN	10 kN	6 bar	6 bar	1,3 kg

Model	Pallet	Weight
HEAD CHANGING PALLET 85PRS	46204615	0,7 kg

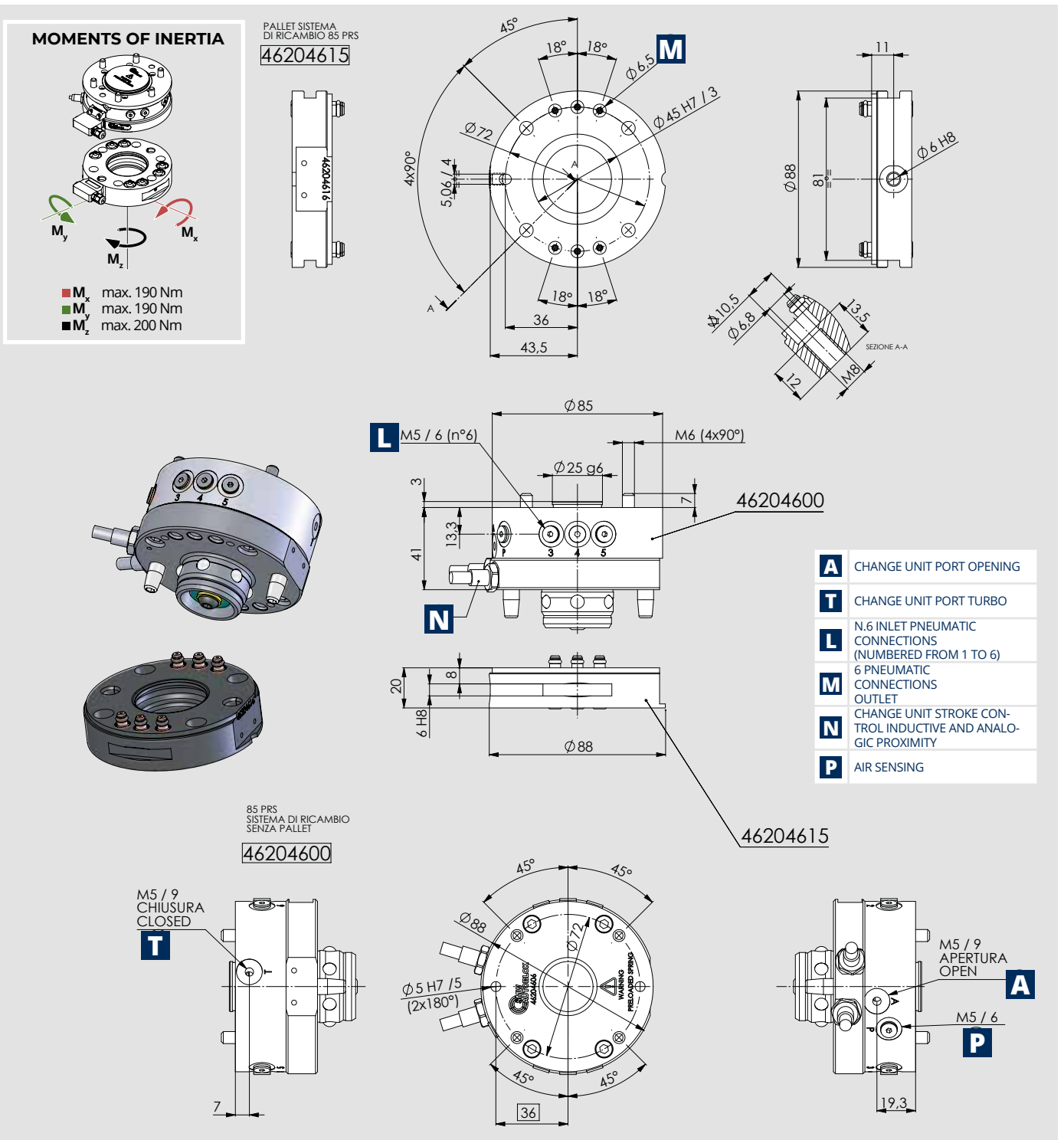

A	CHANGE UNIT PORT OPENING
T	CHANGE UNIT PORT TURBO
L	N.6 INLET PNEUMATIC CONNECTIONS (NUMBERED FROM 1 TO 6)
M	6 PNEUMATIC CONNECTIONS OUTLET
N	CHANGE UNIT STROKE CONTROL INDUCTIVE AND ANALOGIC PROXIMITY
P	AIR SENSING

FLANGE GROUP

for head changing 85 PRS

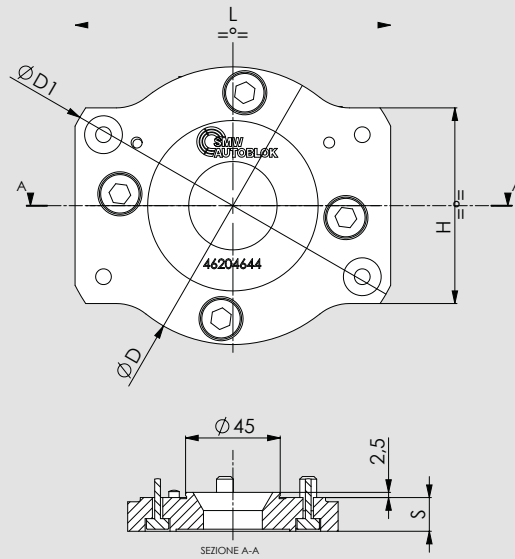

FLANGE KIT ID.No.	D	D1	S	H	L	WEIGHT kg	GRIPPER TYPE MONTABLE
46204640 FLANGE KIT 85PRS/2PXM 125	88	130	18	78	122	0,4	2PXM 125 *
46204642 FLANGE KIT 85PRS/PL - 2PXS 100	88	88	16	/	/	0,3	PL 100 - 2PXS 100 *
46204644 FLANGE KIT 85PRS/PP - PL 125	88	112	16	62	100	0,3	PL 125 - PP 125 *
46204646 FLANGE KIT 85PRS/3MN - 3PXS 100	104	104	16	/	/	0,4	3MN 100 - 3PXS 100 **
46204648 FLANGE KIT 85PRS/3MN - 3PXM 125	118	118	16	/	/	0,5	3MN 125 - 3PXM 125 **

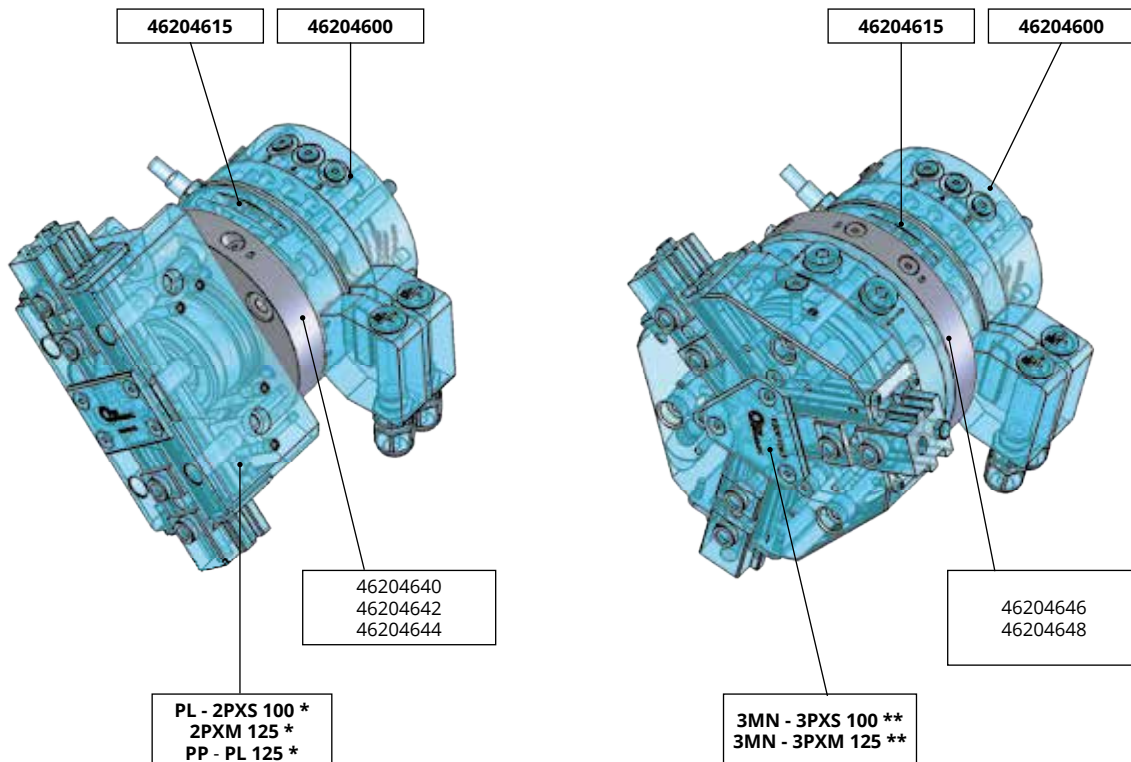

110 PRS PNEUMATIC HEAD CHANGING

- Pneumatic operation
- Spring clamping + TURBO

Function

Automatic head/gripper changing system for robots

Technical features

- Body and internal mechanism case-hardened for higher rigidity and longer life
- Inductive and analogic proximity-based stroke control system (as standard)
- Pneumatic opening

- Spring clamp + TURBO
- Electric signal interface module (optional)
- n.7 pneumatic connectors for media trasmission between the changing unit and the gripper mounting on it.
- hydraulic connectors are not expected

Model	Id.n. (without pallet)	Max liftable weight	Repeatability	pneumatic connections n.	Pull down force		Pressure		Weight
					spring	spring+TURBO	open	TURBO	
110PRS	46204400	75 Kg	0,015 mm	7	2,5 KN	14 KN	6 bar	6 bar	3 Kg

Model	Pallet	Weight
HEAD CHANGING PALLET 110PRS	46204415	1,9 Kg

MOMENTS OF INERTIA

- M_x max. 600 Nm
- M_y max. 600 Nm
- M_z max. 350 Nm

PALLET SISTEMA DI RICAMBIO 110-PRS

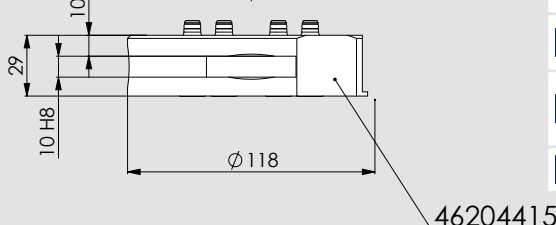
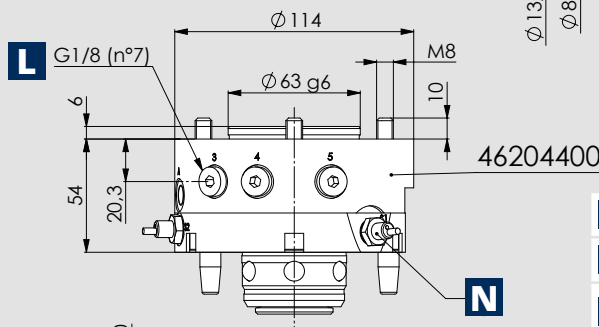
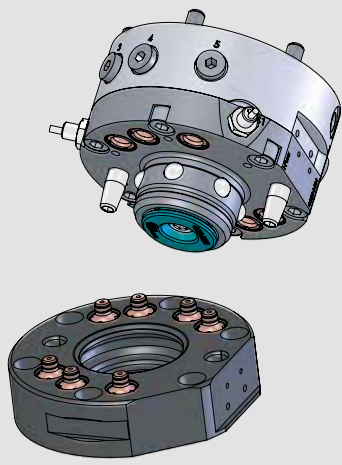
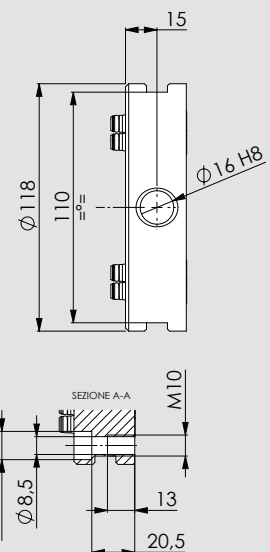
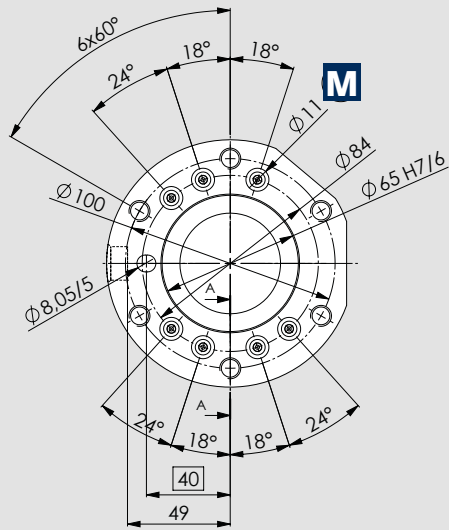
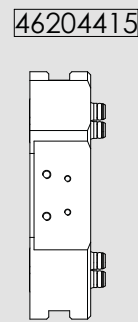

- A** CHANGE UNIT PORT OPENING
- T** CHANGE UNIT PORT TURBO
- L** N.7 INLET PNEUMATIC CONNECTIONS (NUMBERED FROM 1 TO 7)
- M** 7 PNEUMATIC CONNECTIONS OUTLET
- N** CHANGE UNIT STROKE CONTROL INDUCTIVE AND ANALOGIC PROXIMITY OPTIONAL-NOT INCLUDED
- P** AIR SENSING

110 PRS SISTEMA DI RICAMBIO SENZA PALLET
46204400

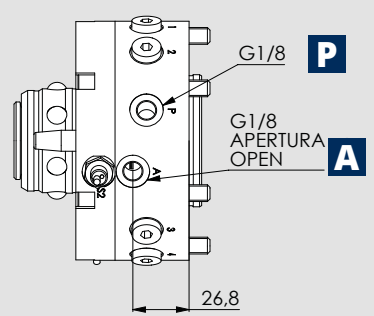
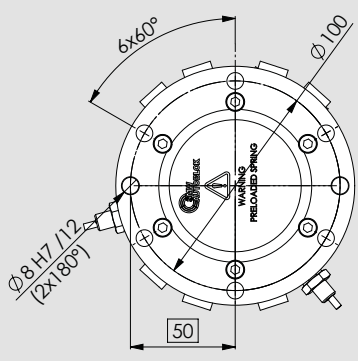
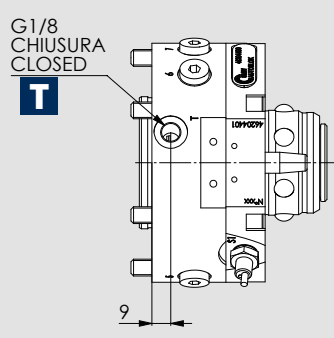

Drawings and data are subject to change by SMW-Autoblok.

FLANGE GROUP

for head changing 110 PRS

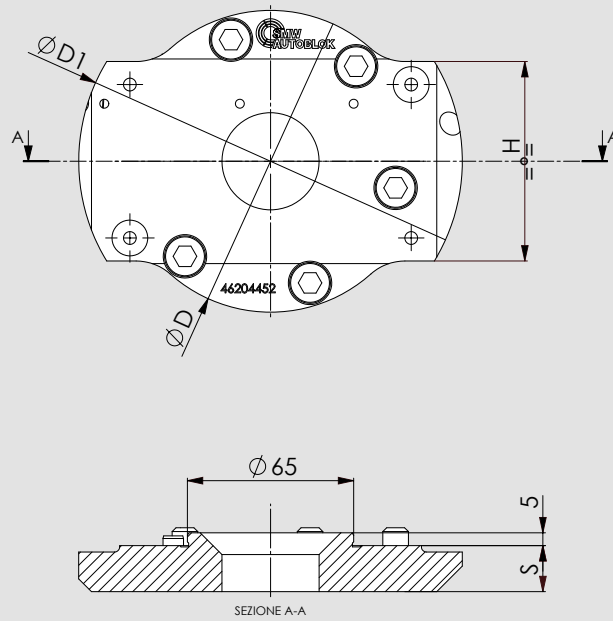

FLANGE KIT ID.No.	D	D1	S	H	WEIGHT kg	GRIPPER TYPE MONTABLE
46204464 FLANGE KIT 110PRS/2PXM 125	122	122	18	/	0,6	2PXM 125 *
46204466 FLANGE KIT 110PRS/2PXM 160	132	132	18	/	0,7	2PXM 160 *
46204450 FLANGE KIT 110PRS/PP - PL 125	118	130	18	90	0,6	PP - PL 125 **
46204452 FLANGE KIT 110PRS/PP - PL 160	118	150	18	78	0,7	PP - PL 160 **
46204458 FLANGE KIT 110PRS/3MN - 3PXM 125	118	118	19	/	0,5	3MN - 3PXM 125 ***
46204460 FLANGE KIT 110PRS/3MN - 3PXM 160	166	166	20	/	1,1	3MN - 3PXM 160 ***

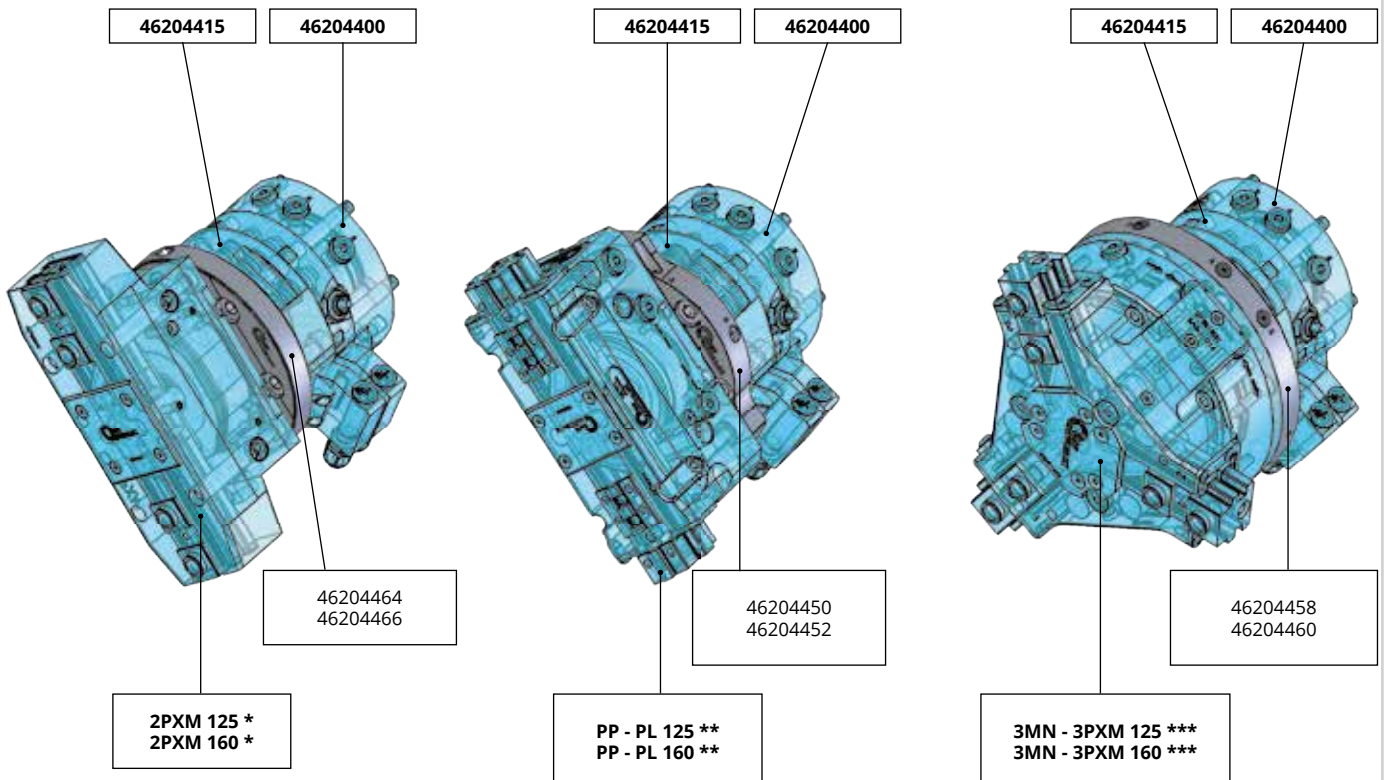

160 PRS HEAD CHANGING

- Pneumatic operation
- Spring clamping + TURBO

Function

Automatic head/gripper changing system for robots

Technical features

- Body and internal mechanism case-hardened for higher rigidity and longer life
- Analogic inductive stroke control system via proximity (as standard)
- Pneumatic opening

- Spring clamp + TURBO
- Electric signal interface module (optional)
- n.7 pneumatic connectors for media trasmission between the changing unit and the gripper mounting on it*

* couplers prepared for pneumatic use; for eventual hydraulic use, request a separate quotation.

Model	without pallet Id.n.	Max liftable weight	Repeatability	pneumatic connections n.	Pull-down force		Pressure		Weight
					spring	spring+TURBO	open	TURBO	
160PRS	46204320	150 Kg	0,015 mm	7	4 KN	19 KN	6 bar	6 bar	6 Kg
Model			Pallet			Weight			
PALLET SISTEMA DI RICAMBIO 160PRS			46204330			4,3 Kg			

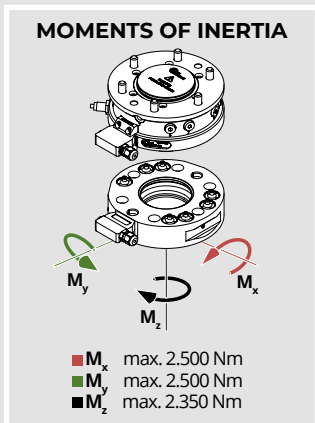

PALLET SISTEMA DI RICAMBIO 160 PRS
46204330

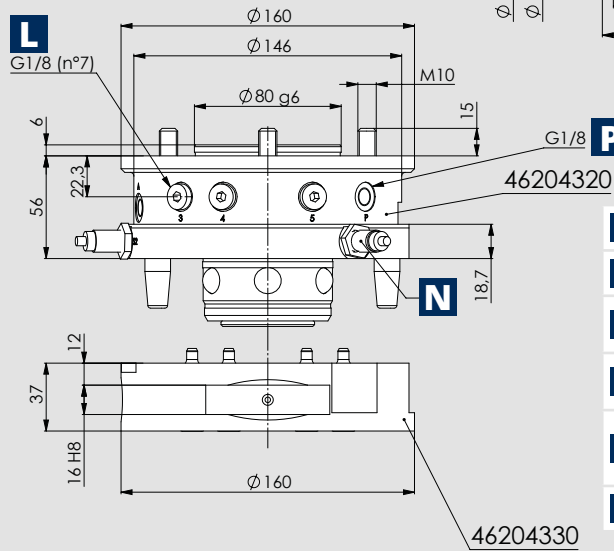
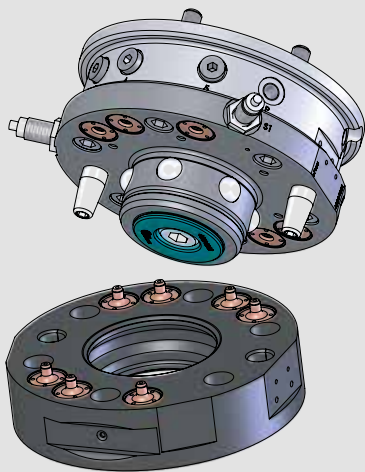
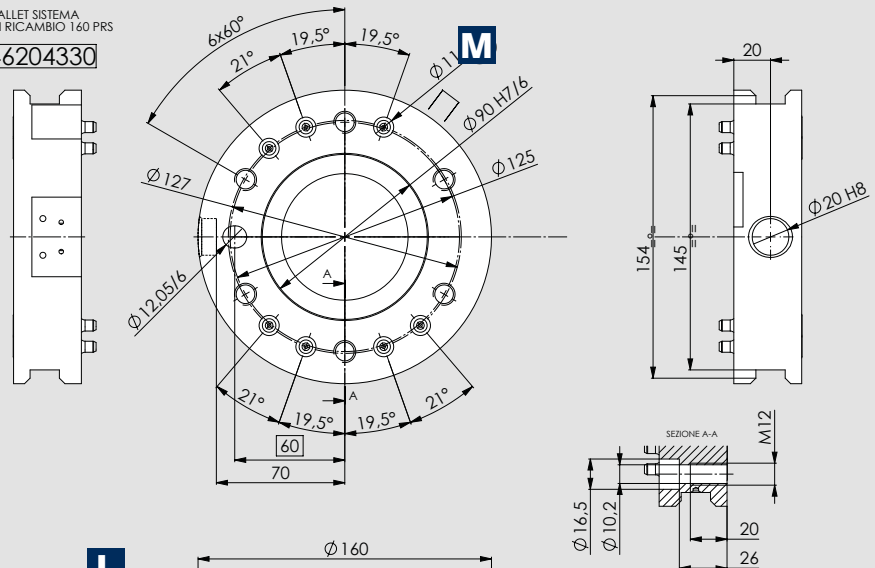

A	CHANGE UNIT PORT OPENING
T	CHANGE UNIT PORT TURBO
L	N.7 INLET PNEUMATIC CONNECTIONS (NUMBERED FROM 1 TO 7)
M	7 PNEUMATIC CONNECTIONS OUTLET
N	CHANGE UNIT STROKE CONTROL INDUCTIVE AND ANALOGIC PROXIMITY OPTIONAL-NOT INCLUDED
P	AIR SENSING

160 PRS SISTEMA DI RICAMBIO SENZA PALLET
46204320

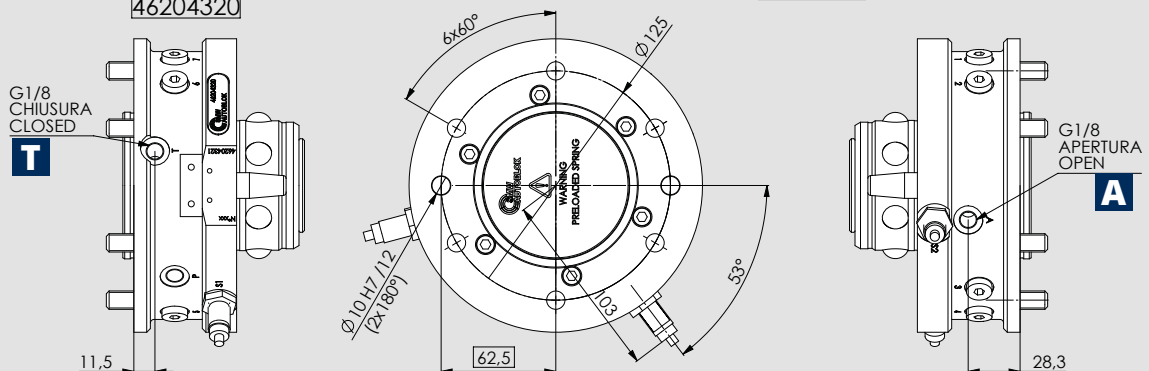

Drawings and data are subject to change by SMW-Autoblok.

FLANGE KIT for pneumatic head changing 160 PRS

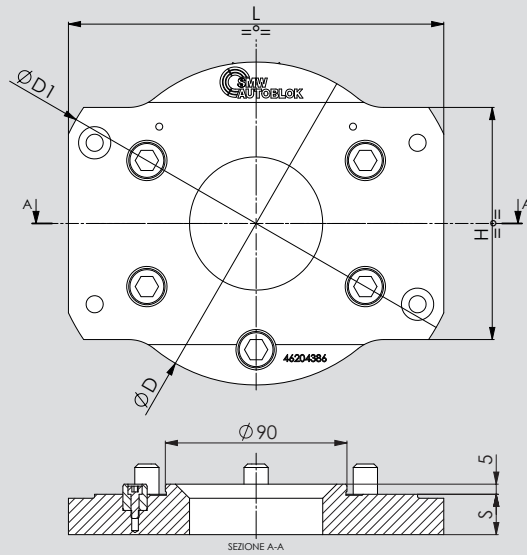

FLANGE KIT ID.No.	D	D1	S	H	L	WEIGHT kg	GRIPPER TYPE MONTABLE
46204382 FLANGE KIT 160PRS-2V/2PXM 160	160	160	20	/	/	1,1	2PXM 160 *
46204384 FLANGE KIT 160PRS-2V/2PXM 20	168	168	20	/	/	1,2	2PXM 200 *
46204386 FLANGE KIT 160PRS-2V/2PXL 250	160	206	20	115	186	1,3	2PXL 250 *
46204362 FLANGE KIT 160 PRS-2V/PP - PL 160	160	160	21	/	/	1,1	PP - PL 160 **
46204364 FLANGE KIT 160 PRS-2V/PP - PL 200	160	190	21	98	/	1,3	PP - PL 200 **
46204366 FLANGE KIT 160 PRS-2V/PP - PL 250	160	212	21	120	/	1,5	PP - PL 250 **
46204372 FLANGE KIT 160 PRS-2V/3MN - 3PXM 160	166	166	20	/	/	1	3MN - 3PXM 160 ***
46204374 FLANGE KIT 160 PRS-2V/3MN - 3PXM 200	202	202	21	/	/	1,7	3MN - 3PXM 200 ***
46204376 FLANGE KIT 160 PRS-2V/3MN - 3PXL 250	232	232	21	/	/	2,3	3MN - 3PXL 250 ***

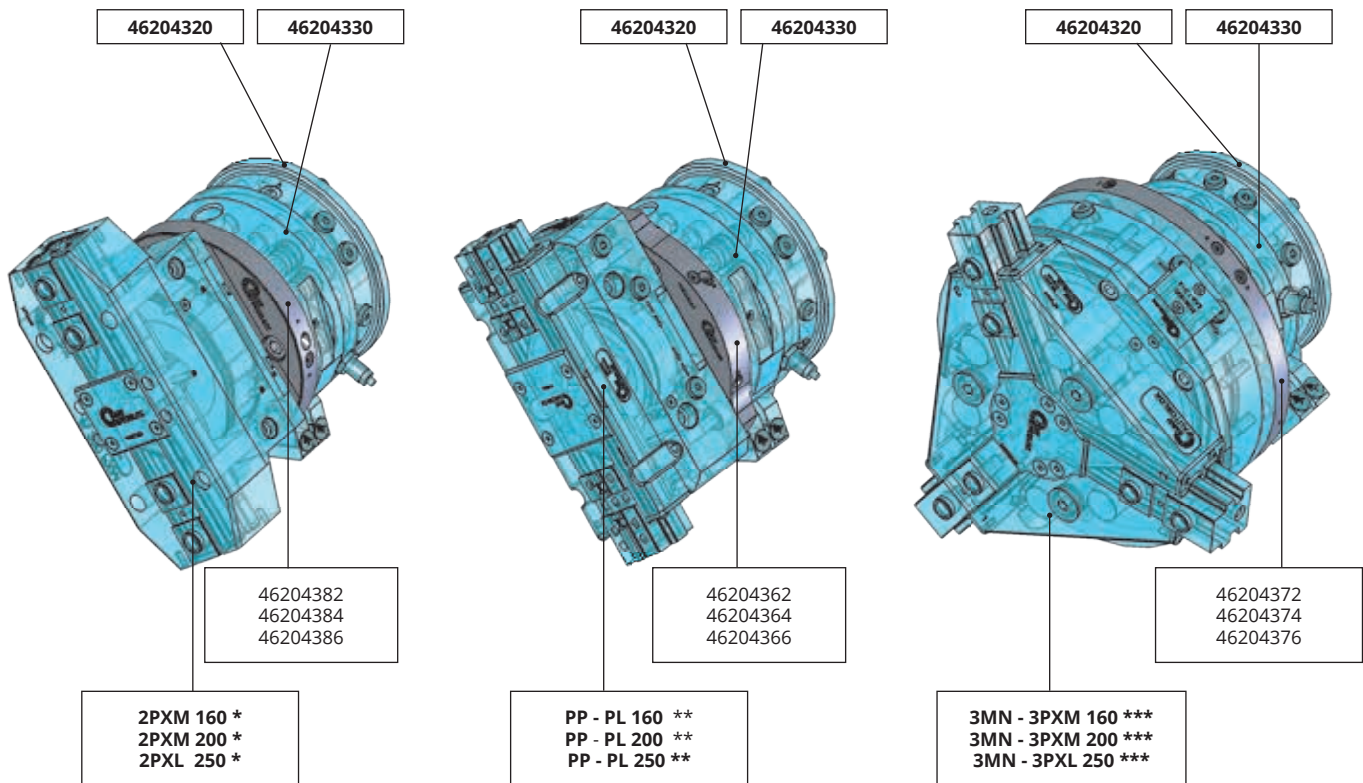

Drawings and data are subject to change by SMW-Autoblok.

240 PRS HEAD CHANGING

- Pneumatic operation
- Spring clamping + TURBO

Function

Automatic head/gripper changing system for robots

Technical features

- Body and internal mechanism case-hardened for higher rigidity and longer life
- Analogic inductive stroke control system via proximity (as standard)
- Pneumatic opening

- Spring clamp + TURBO
- Electric signal interface module (optional)
- n.7 pneumatic connectors for media trasmission between the changing unit and the gripper mounting on it*

* couplers prepared for pneumatic use; for eventual hydraulic use, request a separate quotation.

Model	without pallet Id.n.	Max liftable weight	Repeatability	pneumatic connections n.	Pull-down force		Pressure		Weight
					spring	spring+TURBO	open	TURBO	
240PRS	46204500	500Kg	0,015 mm	7	12,5 KN	76 KN	6 bar	6 bar	16 Kg
Model			Pallet			Weight			
QUICK PALLET CHANGE 240PRS			46204515			9,5 Kg			

MOMENTS OF INERTIA

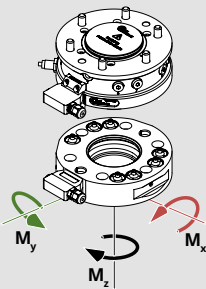

- M_x max. 10.000 Nm
- M_y max. 10.000 Nm
- M_z max. 10.000 Nm

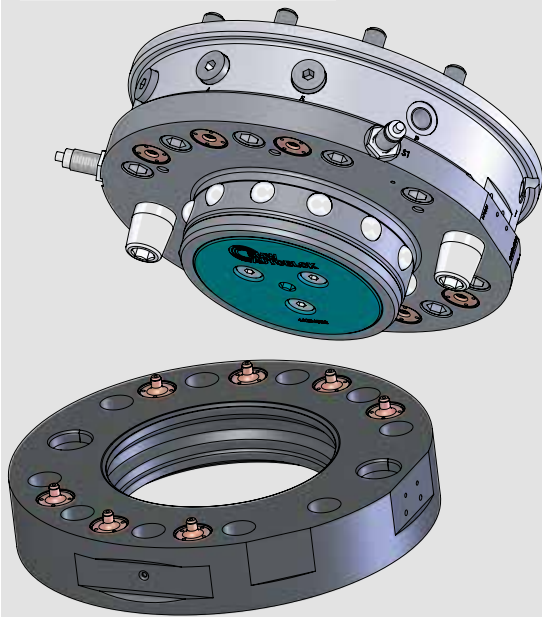

PALLET SISTEMA DI RICAMBIO 240 PRS
46204515

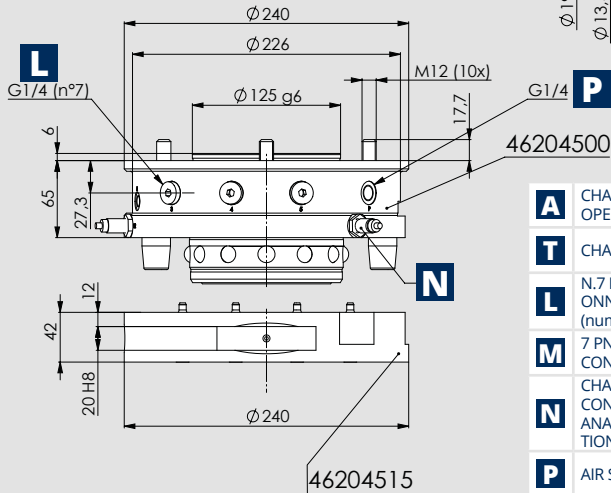
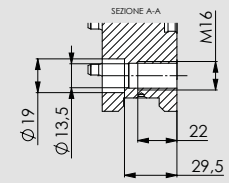
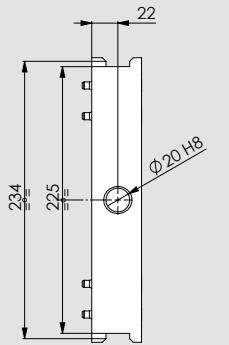
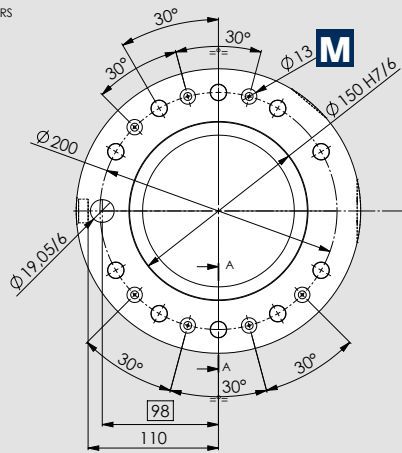
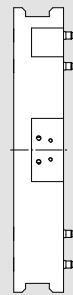

A	CHANGE UNIT PORT OPENING
T	CHANGE UNIT PORT TURBO
L	N.7 INLET PNEUMATIC ONNECTIONS (numbered 1 to 7)
M	7 PNEUMATIC CONNECTIONS OUTLET
N	CHANGE UNIT STROKE CONTROL INDUCTIVE AND ANALOGIC PROXIMITY OPTIONAL-NOT INCLUDED
P	AIR SENSING

240 PRS SISTEMA DI RICAMBIO SENZA PALLET
46204500

G1/8 CHIUSURA CLOSED
T

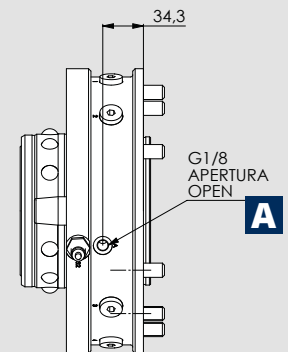
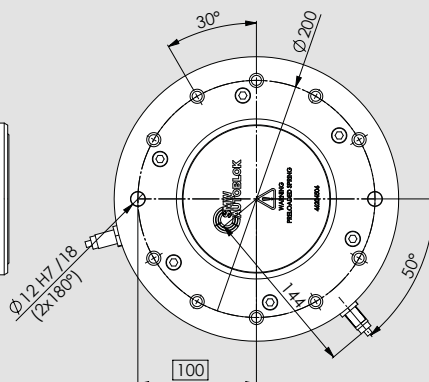
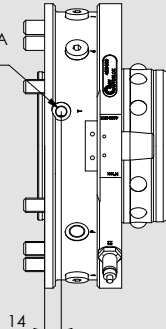

FLANGE GROUP

for head changing 240 PRS

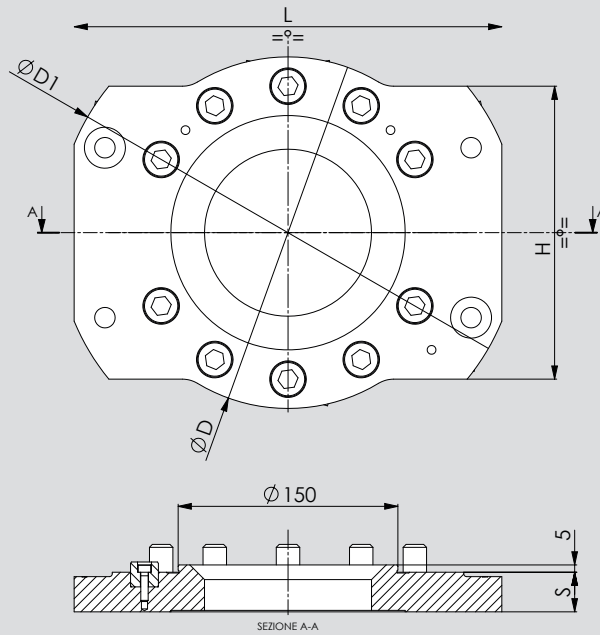

FLANGE KIT Id.No.	D	D1	S	H	L	WEIGHT kg	GRIPPER TYPE MONTABLE
46204538 FLANGE KIT 240PRS/2PXL 250	240	240	23	/	/	2,9	2PXL 250 *
46204540 FLANGE KIT 240PRS/PL 320	240	240	27	/	/	3,2	PL 320 *
46204542 FLANGE KIT 240PRS/PL 380	240	316	27	200	292	4,2	PL 380 *
46204544 FLANGE KIT 240PRS/3MN - 3PXL 250	240	240	23	/	/	2,6	3MN - 3PXL 250 **
46204546 FLANGE KIT 240PRS/3MN 320	310	310	23	/	/	4,7	3MN 320 **
46204548 FLANGE KIT 240PRS/3MN 380	380	380	27	/	/	8,3	3MN 380 **

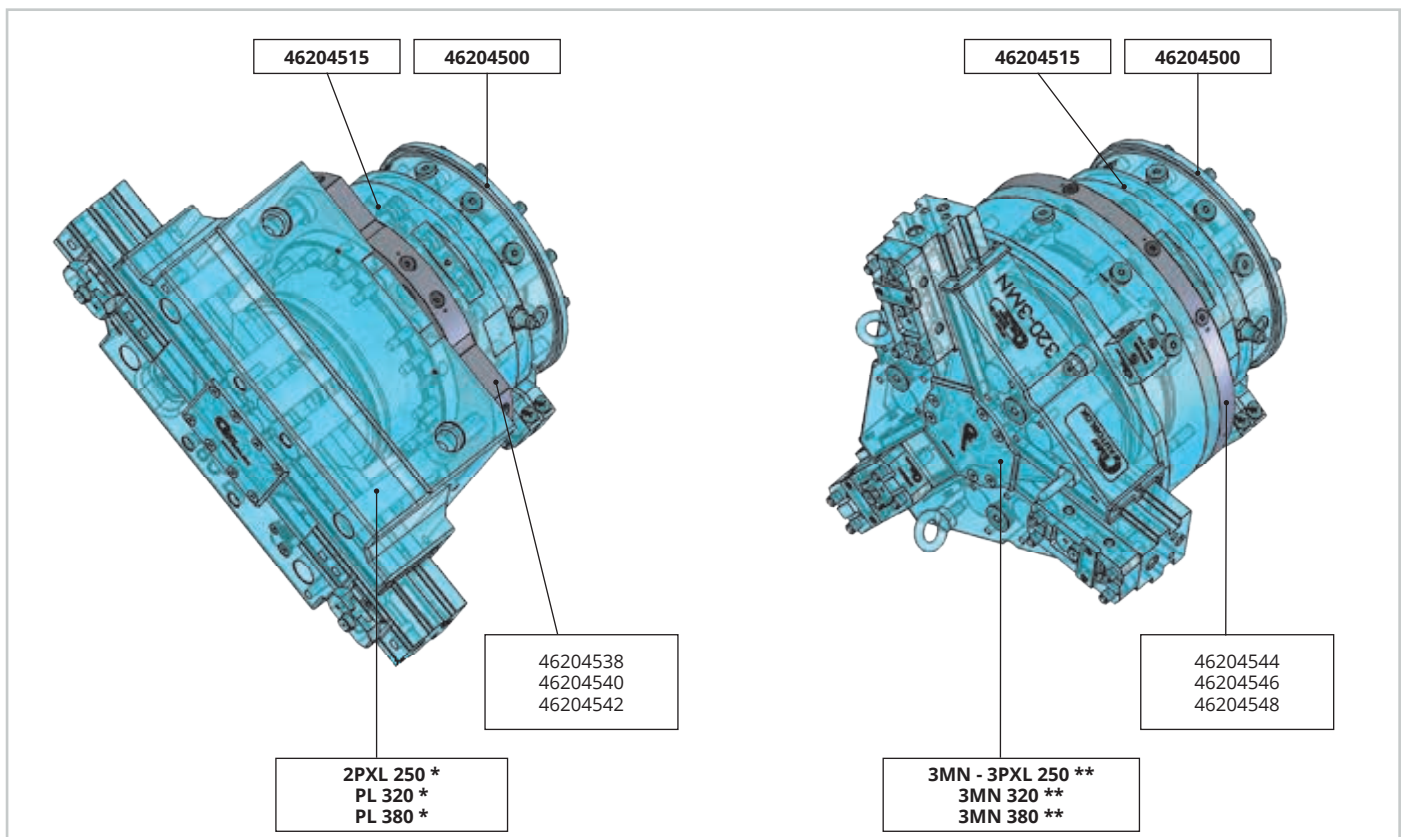

Drawings and data are subject to change by SMW-Autoblok.

CONNECTORS AND SENSORS

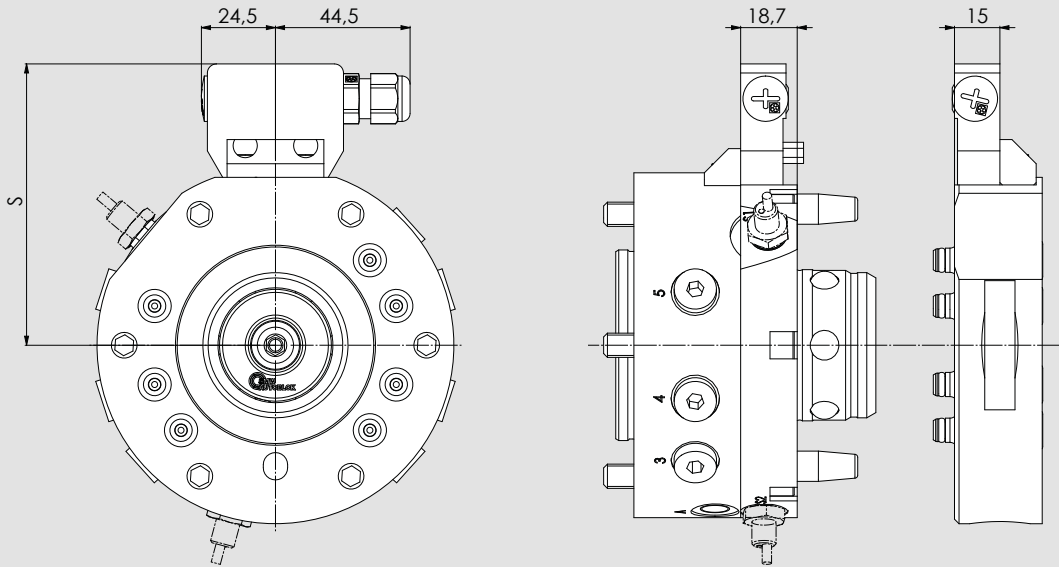

PRS Type		Id.N.	Description
55-85	ROBOT SIDE	71820303	Spring female connector
	GRIPPER SIDE	71820304	Spring male connector
110-160-240	ROBOT SIDE	46204420	Spring female connector kit
	GRIPPER SIDE	46204419	Spring male connector kit

CONNECTORS and SENSORS C40 SMW-Autoblok

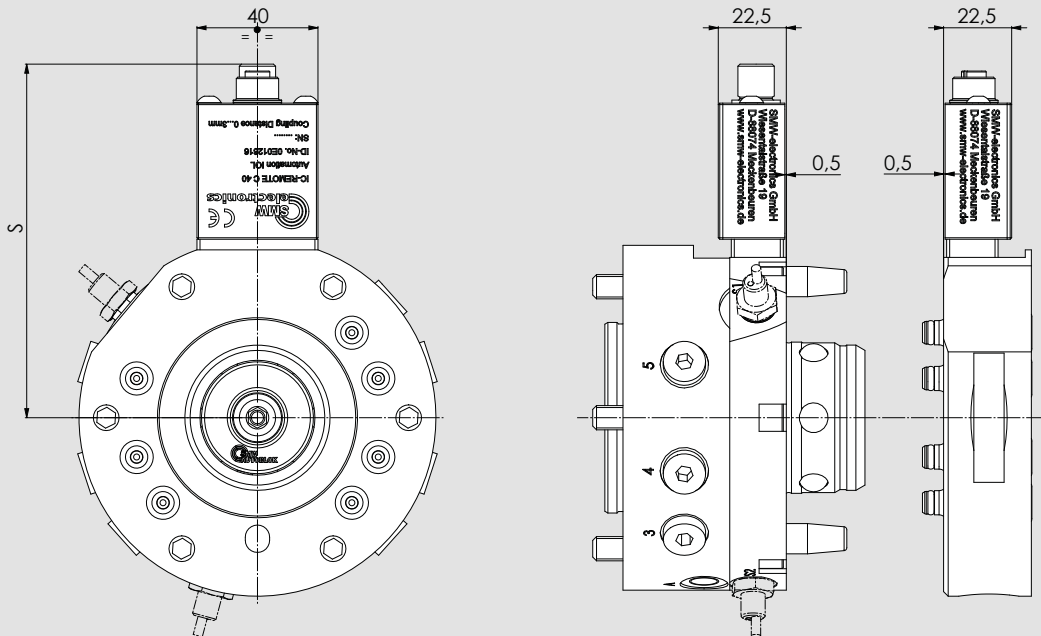

Technical data

- Cubical coupling system (40x45x22 mm)
- Ideal suited for EOAT applications
- Power supply 24V
- Transmission distance 0 - 3 mm
- Energy transmission 15W (24V)
- Signal transmission
- IO-Link (COM 1, COM 2, COM 3) / 6 PNP Signals + 2 Analog signals 0-10V
- IP67 Protection class

for more details see Mechatronik chapter

8



MECHATRONIC

216 MECHATRONIC GRIPPERS

220 TRANSMISSION SYSTEMS

226 APPLICATION EXAMPLES

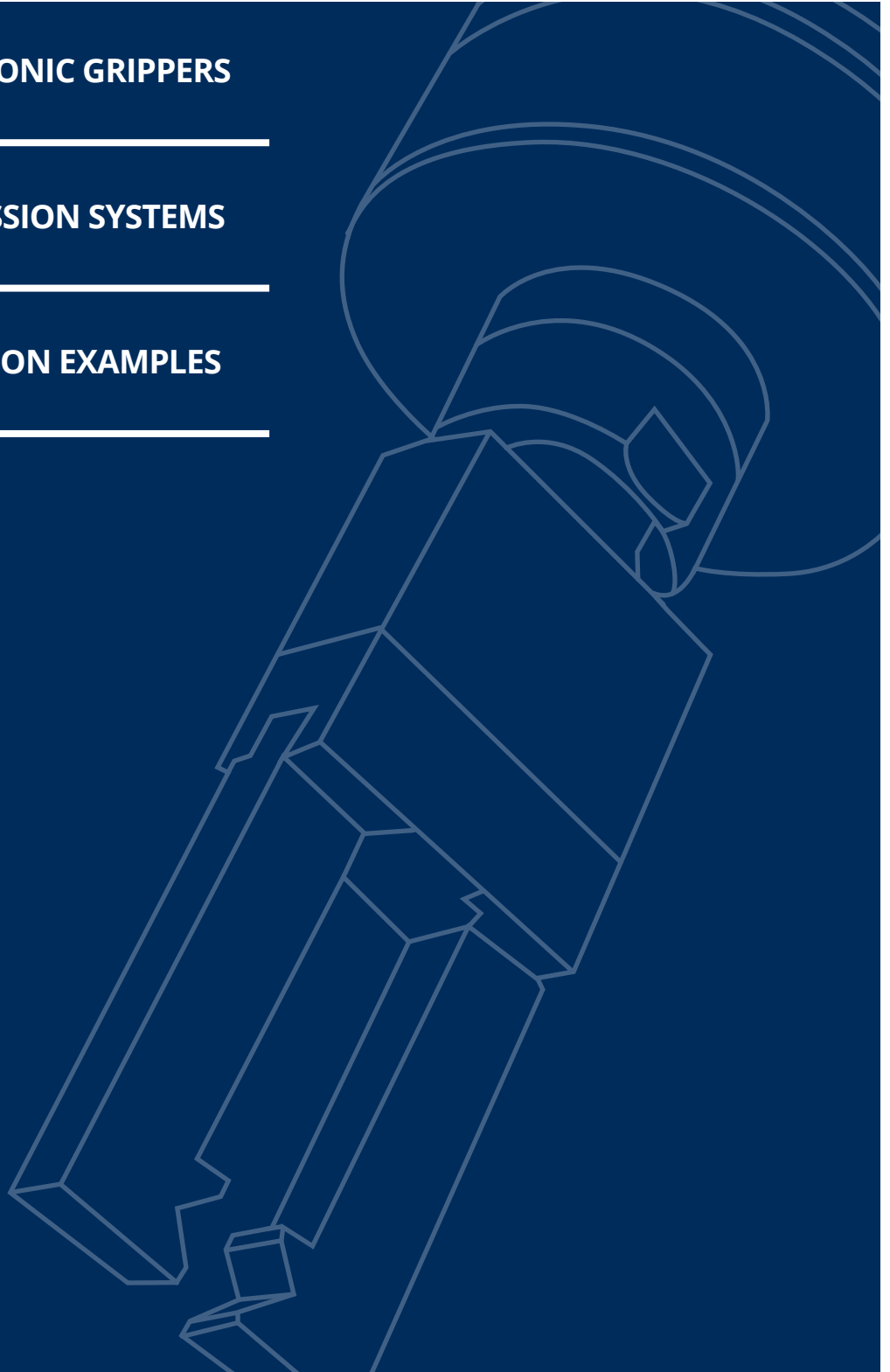

MECHATRONIC GRIPPERS

Product line MOTIACT



360° Rotation

Benefits

- Clamping force independent of gripping speed and stroke
- Clamping force retention in case of power failure
- Measuring system (absolute sensor) to monitor the gripping position.
- Safety features (self-locking; MX-L = additional features)
- Optional use of inductive coupling systems for 360° rotation. Contactless wear-free transmission of energy and signals.
- Pre-positioning and sensitive clamping force adjustment.
- IO-Link / Profinet interfaces with intelligent motion profiles.
- IP67 Protection class (MX-S = IP40)

OPTIONAL

- MX-S -> Speed-Version (coming soon)

MX-S

- Small parts gripper
- 2 fingers parallel
- 50
- Communication interface: IO-Link / Digit IO



MX-S 050 Technical data

- L/W/H 52x34x96 mm
- Stroke per jaw: 8 mm
- Clamping force open/close 20 daN
- IP40 Protection class
- Repeatability: 0,02 mm
- Clamping force retention due to self locking and spring assembly
- Communication interface: IO-Link / Digit IO

MX-M

- Universal gripper
- 2 fingers parallel
- 80
- Communication interface: IO-Link / Digit IO



MX-M 080 Technical data

- L/W/H 96x44x106 mm
- Stroke per jaw: 8 mm
- Clamping force open/close 120 daN
- IP64 Protection class
- Repeatability: 0,02 mm
- Clamping force retention due to self locking and spring assembly
- Communication interface: IO-Link / Digit IO

MX-L

- Long stroke gripper
- 2 fingers parallel
- 520
- Communication interface: Profinet / EtherNet/IP



MX-L 520 Technical data

- L/W/H 520x180x138 mm
- Stroke per jaw: 99 mm
- Clamping force open/close 1.000-4.000 daN
- IP67 Protection class
- Repeatability: 0,02 mm
- Clamping force retention due to self locking and spring assembly and additional engine brake
- Communication interface: Profinet / EtherNet/IP

MX

Mechatronic small parts GRIPPER 50

S

2 fingers parallel



Technical features

- External and internal clamping
- Adjustable gripping position and force
- Repeatability 0,02 mm
- Recommended workpiece weight up to 1 kg
- Power supply 19.2 ... 30V / 2A
- Communication interface IO-Link (Id.No. 480020) or Digital IO (Id. No. 480120)
- Delivery included 2x centering sleeves for gripper fastening, without gripper fingers

Applications/Customer benefits

- Clamping force independent of gripping speed and stroke
- Mechatronic drive with clamping force retention
- Position measuring system (absolute)
- Pre-positioning and clamping force adjustment
- IP40 Protection class
- Suitable for use as small parts gripper due to lightweight and compact design
- Also suitable for cobot applications and pick & place tasks

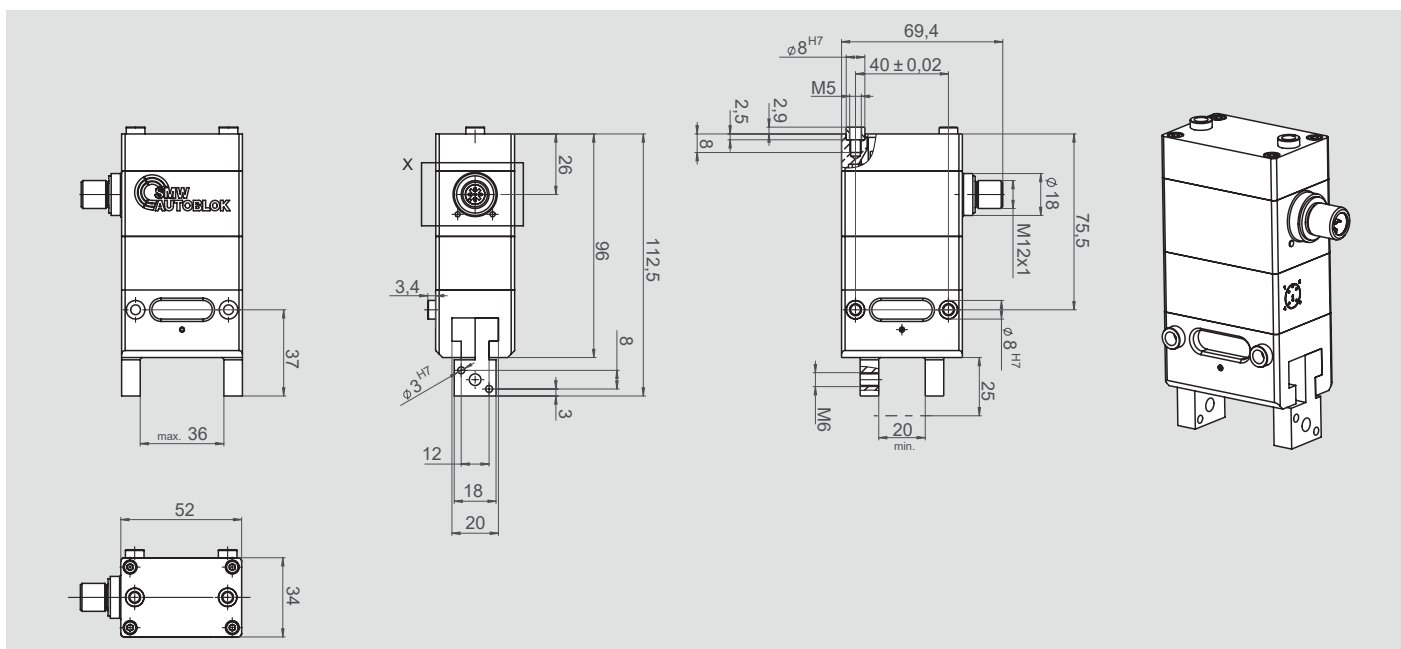

Drawings and data are subject to change by SMW-Autoblok.

SMW-Autoblok TYPE		MX-S 050 IOL	MX-S 050 DIO
Id.No.		480020	480120
Total clamping force	N	200	200
Stroke per jaw	mm	8	8
Repeatability	mm	0,02	0,02
Weight	kg	0,58	0,58
Max. Workpiece weight	kg	1	1
Voltage	V	Ua 19.2 ... 30 V, Us 18 ... 30 V	19.2 ... 30 V
Power	A	IS ≤ 100 mA, IA ≤ 2 A	< 2 A
Idle current (in non-moving state)	mA	IS = IA < 100	I < 100
Protection class		IP40	IP40
Interface		IO - LINK	Digital IO

MX

Mechatronic Universal GRIPPER 80

M

2 fingers parallel



Technical features

- External and internal clamping
- Adjustable gripping position and force
- Repeatability 0,02 mm
- Recommended workpiece weight up to 6 kg
- Power supply 19.2 ... 30 V / 5 A
- Communication interface IO-Link (Id.No. 480040) or Digital IO (Id.No. 480140)
- Delivery included 2x centering sleeves for gripper fastening, without gripper fingers

Applications/Customer benefits

- Clamping force independent of gripping speed and stroke
- Mechatronic drive with clamping force retention
- Position measuring system (absolute)
- Pre-positioning and clamping force adjustment
- IP64 Protection class
- Use as universal gripper

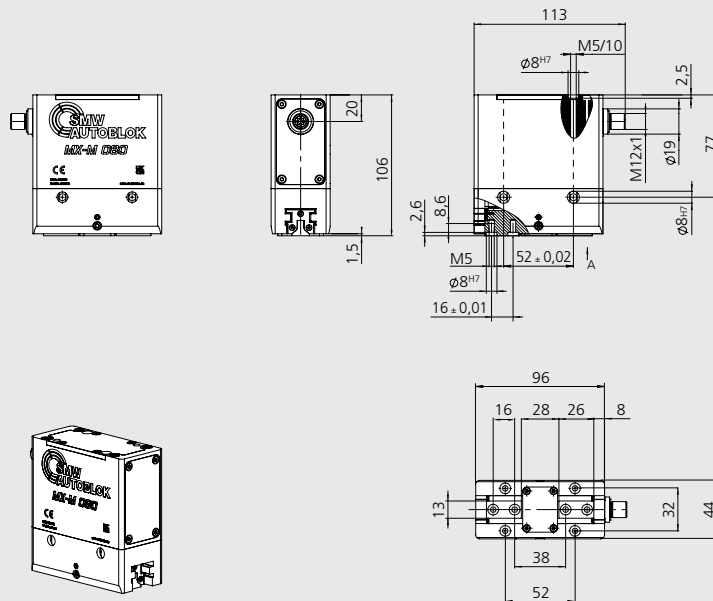

SMW-Autoblok TYPE		MX-M 080 IOL	MX-M 080 DIO
Id.No.		480040	480140
Total clamping force	N	1200	1200
Stroke per jaw	mm	8	8
Repeatability	mm	0,02	0.02
Weight	kg	1,35	1,35
Max. Workpiece weight	kg	6	6
Voltage	V	19.2 ... 30 V	19.2 ... 30 V
Power	A	< 5 A	< 5 A
Protection class		IP64	IP64
Interface		IO-Link	Digital IO

MX

Mechatronic Long stroke GRIPPER 520

L

2 fingers parallel



Technical features

- Clamping force 10 - 40 kN; external clamping
- Repeatability 0,02 mm
- Recommended workpiece weight 200 kg
- proofline = sealed - low maintenance
- Power supply 48V / 10A
- Communication interface Profinet (EtherNet/IP communication on request)
- 2 STO Signals

Applications/Customer benefits

- Clamping force independent of gripping speed and stroke
- Mechatronic drive with clamping force retention in case of power failure
- Clamping force up to 40 kN
- Position sensing and monitoring of the clamping force
- Pre-positioning and sensitive clamping force adjustment
- Lightweight housing
- IP67 Protection class

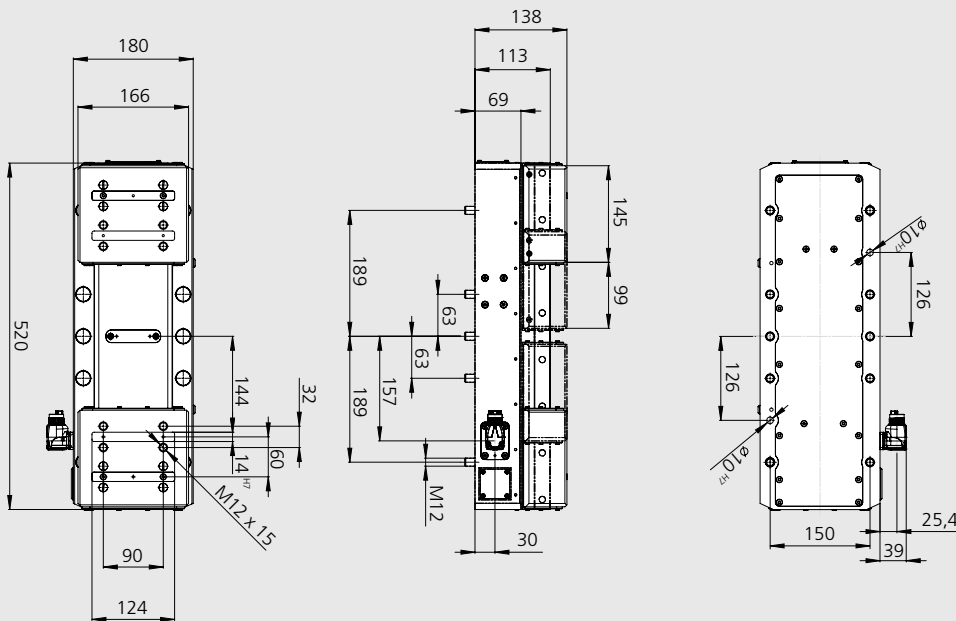

SMW-Autoblok TYPE		MX-L 520
Id.No.		480000
Total clamping force	kN	10 - 40
Stroke per jaw	mm	99
Repeatability	mm	0.02
Weight	kg	47
Max. Workpiece weight	kg	200
Voltage	V	48
Power	A	10
Protection class		IP 67
Interface		Profinet 480000 EtherNet/IP 480200

TRANSMISSION SYSTEMS

Inductive coupling systems for wear-free power and signal transmission



Inductive Coupling System

F100
F100 ETH Ethernet Transmission
F100 IO 2x IO-Link Transmission

- OD = 100 mm
- ID = 50 mm
- Height = 25 mm
- Energy transmission ~ 75W/ 24V

MOTIACT Gripper

3 Product Lines

- MX-S Small
- MX-M Medium
- MX-L Large

F180 ETH



Technical data

- Diameter Ø 180 mm
- Pass through Ø 85 mm
- Power supply 24V/ 48V
- Transmission distance 0 - 5 mm
- Energy transmission 240W (24V) / 400W (48V)
- Signal transmission Ethernet 100 Base-T
- IP67 Protection class

F100 ETH / F100 2IOL



Technical data

- Diameter Ø 100 mm
- Pass through Ø 50 mm
- Power supply 24V
- Transmission distance 0 - 4 mm
- Energy transmission 75W (24V)
- Signal transmission Ethernet 100 Base-T/
- 2x IO-Link (COM 1, COM 2, COM 3)
- IP67 Protection class

F

F180 Ethernet Inductive Coupling System

180

Contact free transmission of energy and signals



Technical features

- Diameter: 180 mm / Through hole: 85 mm
- Operating voltage: 24 V or 48 V
- Transmission distance: 0 - 5 mm at 24 V or 0 - 3 mm at 48 V
- Energy transmission: 24 V / 240 W or 48 V / 400 W (settable)
- Signal transmission: Ethernet 100 Base-T
- Transmission bandwidth < 5 MBit/s
- Connections: M12 Ethernet (D-coded), M12 Diagnosis (A-coded), terminal block (Energy)
- Protection class: IP 67

Applications/Customer benefits

- Contact free, safe transmission of energy and signals between moving / rotating and stationary components
- Application examples: Packaging machines, special machines, Automation, Machine Tools, Printing Machines, Robot applications (EOAT)
- Substitution of slip ring / connector
- Dynamic Pairing
- Wear and maintenance free
- Protective functions: temperature monitoring, foreign object detection
- Multi-level LED with good visibility

Block diagram:

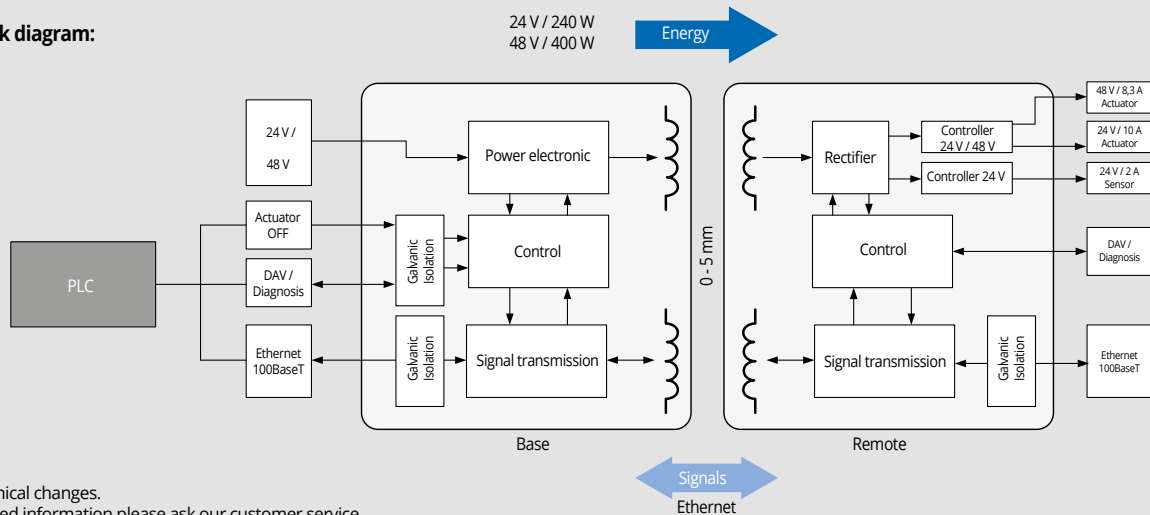

Subject to technical changes.
For more detailed information please ask our customer service.

SMW-Autoblok TYPE	Base	Remote
Id.No.	0E011246	0E011247
Operating temperature (body surface)	-20° C ... +60° C	
Stocking temperature	-20° C ... +60° C	
Transmission distance	0 mm ... 5 mm (24 V) 0 mm ... 3 mm (48 V)	
Operating voltage	24 V / 48 V	-
Output voltage (Actuator supply)*	-	24 V DC / 10 A 48 V DC / 8,3 A
Output voltage (Sensor supply)*	-	24 V DC / 4 A
Signal transmission	Ethernet 100 Base-T	
LED function display	3 LEDs 2x	
Current consumption (base)	15 A (24 V) 12 A (48 V)	-
Overload protection / short-circuit protection	√	√
Reverse polarity protection	-	< 50 mV
Data valid output	max. 100 mA	-
Ready delay	< 1 s	

F

F100 - 2IOL Inductive Coupling System

100

Contact free transmission of energy and signals



Technical features

- Diameter 100 mm / Through hole 50 mm
- Operating voltage 24 V / max. 6 A
- Transmission distance 0 - 4 mm
- Transmission of energy 24 V / 75 W
- Transmission of signals: 2 x IO-Link (COM 1, COM 2, COM 3)
- Connections: Base: 2x M12 x 1 male 5-pin
- Remote: 2x M12 x 1 female 5-pin
- Protection class: IP 67

Applications/Customer benefits

- Contact free, safe transmission of energy and signals between moving / rotating and stationary components
- Application examples: Robotic (End of Arm Tooling), Automation, Mechanical engineering
- Substitution of slip ring / connector
- Dynamic Pairing
- Wear and maintenance free
- Protective functions: temperature monitoring, foreign object detection, reverse polarity protection
- Multi-level LED with good visibility

Block diagram:

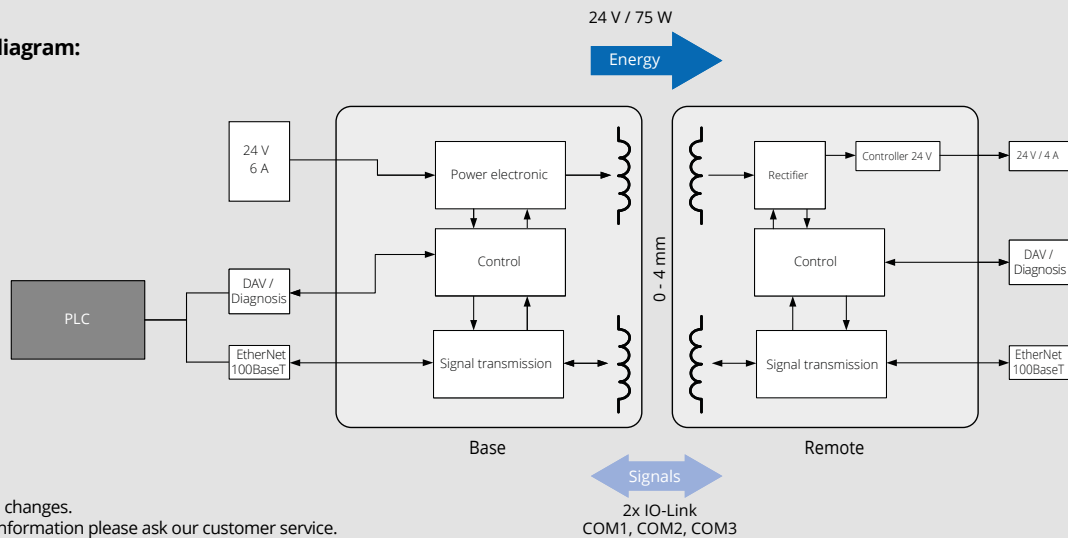

SMW-Autoblok TYPE	Base	Remote
Id.No.	0E012330	0E012331
Operating temperature (housing surface)	-20 °C ... +60 °C	
Storage temperature	-20 °C ... +60 °C	
Transmission distance	0 mm ... 4 mm	
Operating voltage	24 V	-
Output voltage	-	24 V (75 W)
Signal transmission	2x IO-Link (COM1, COM2, COM3)	
LED	2 LEDs 2x--color	
Current consumption (Base)	6 A (24 V)	-
Overload protection / short circuit protection	√	√
Residual ripple	-	< 50 mV
Reverse polarity protection	√	√
Data-Valid output	max. 100 mA	
Ready delay	< 1s	

TRANSMISSION SYSTEMS

Inductive coupling systems for wear-free power and signal transmission

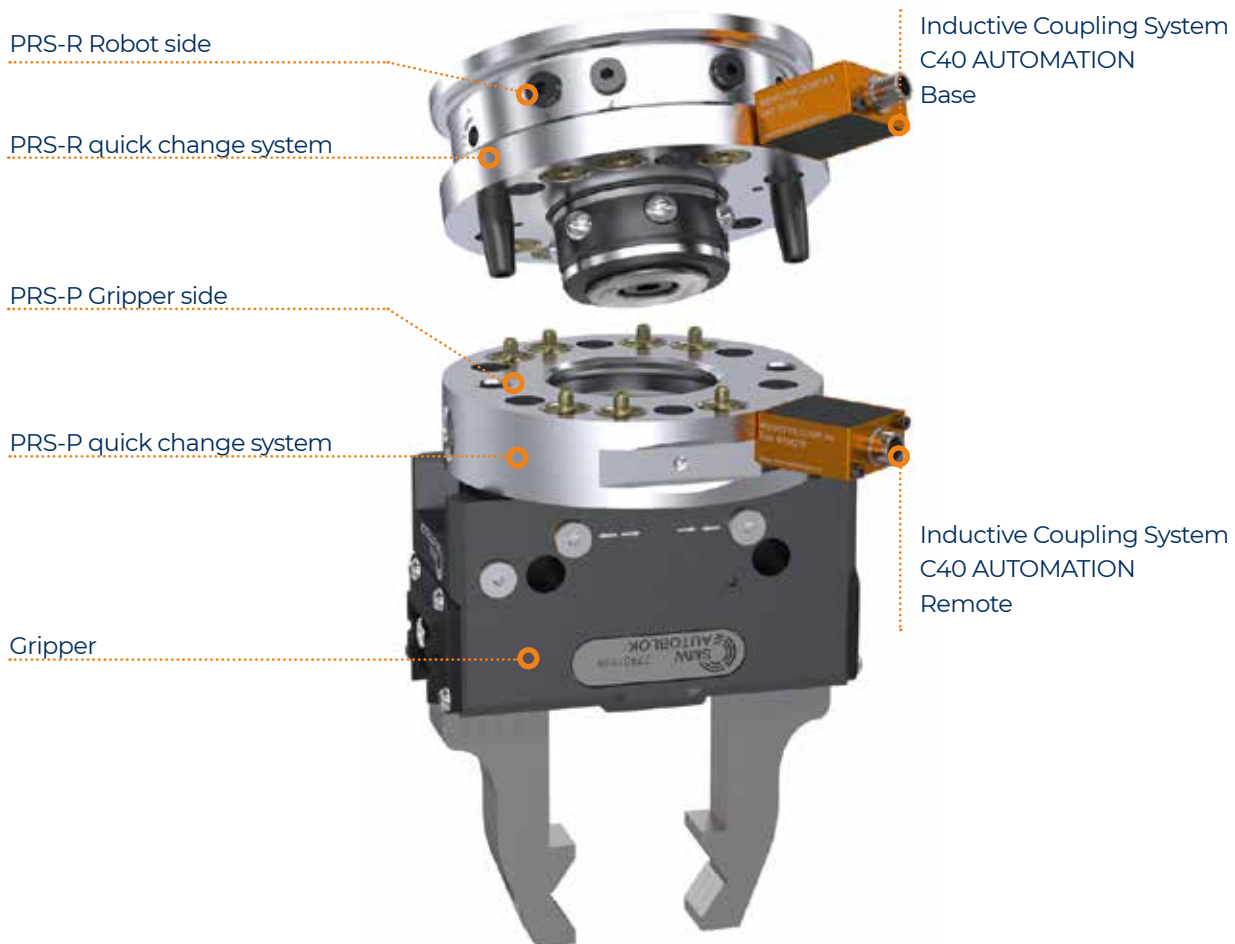

C40 AUTOMATION



Technical data

- Cubical coupling system (40x45x22 mm)
- Ideal suited for EOAT applications
- Power supply 24V
- Transmission distance 0 - 3 mm
- Energy transmission 15W (24V)
- Signal transmission
- IO-Link (COM 1, COM 2, COM 3) / 6 PNP Signals + 2 Analog signals 0-10V
- IP67 Protection class

C40-IOL

- Inductive Coupling System
- AXIAL coupler



Function

- Contact free, safe transmission of energy and signals between moving and stationary components.
- Application examples: operation of sensors in gripper changing systems (EOAT) and pallet change applications.
- Easy retrofit solutions due to mounting kit
- Dynamic Pairing
- Wear and maintenance free
- Protective functions: temperature monitoring, foreign object detection, reverse polarity protection

Technical features

- Mounting via 2x M4 mounting screws (stainless steel)
- Operating voltage 24 V (18 ... 30 V)
- Transmission distance 0 - 3 mm
- Transmission of energy 24 V / 15 W
- Transmission of signals: 1 x IO-Link (COM 1, COM 2, COM 3)
- Connections:
 - Base: M12 x 1 male 5-pin
 - Remote: M12 x 1 female 5-pin
- Protection class: IP 67
- Id.No. Base: 0E012615 / Id.No. Remote: 0E012616

Block diagram:

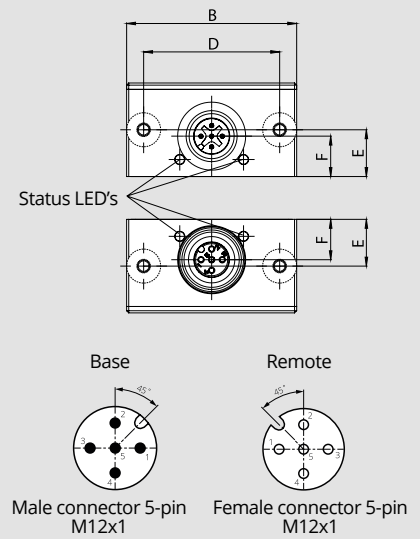
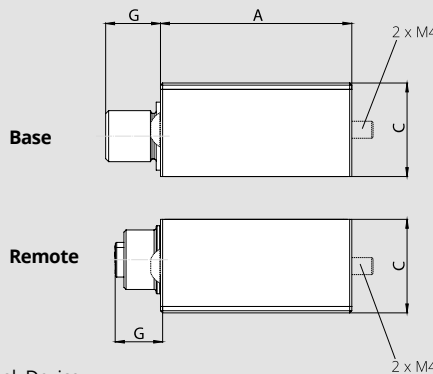
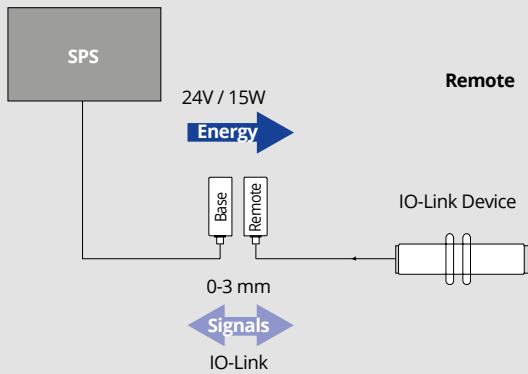

Inductive coupling system C40-IOL			
SMW-electronics Type		BASE	REMOTE
Id. No.		0E012615	0E012616
A	mm	45	45
B	mm	40	40
C	mm	22	22
D	mm	32	32
E	mm	11	11
F	mm	9,5	9,5
G	mm	13	10,6
H	mm	M12x1 / Male	M12x1 / Female
Housing material		AL	AL
Protection class		IP 67	IP 67
Operating temperature		-20° C ... +50° C	-20° C ... +50° C
Storage temperature		-20° C ... +80° C	-20° C ... +80° C
Transmission distance		0-3 mm	0-3 mm
Weight	kg	0,09	0,09
Operating voltage		24 V (18 ... 30 V)	-
Output voltage		-	24 V ± 10% DC
Power consumption (Base)		2000 mA	-
Power output (Remote)		-	625 mA
Overload protection / short circuit protection		-	-
Residual ripple		-	< 200 mV
Reverse polarity protection		-	-
Temperature monitoring		-	-
Data-Valid Output		150 mA	-
Ready delay		< 600 ms	< 600 ms
PIN assignment		SIGNALE BASE	SIGNALE REMOTE
Supply voltage	1	24 V IN	24 V OUT
Digital signal	2	-	-
Ground	3	GND	GND
IO-Link Signal	4	IO-Link CQ	IO-Link CQ
Data-Valid	5	DAV 24 V	-

C40-2x 0-10V / 6PNP

- Inductive Coupling System
- AXIAL coupler



Function

- Contact free, safe transmission of energy and signals between moving and stationary components
- Application examples: operation of sensors in gripper changing systems (EOAT) and pallet change applications
- Easy retrofit solutions due to mounting kit
- Dynamic Pairing
- Wear and maintenance free
- Protective functions: temperature monitoring, foreign object detection, reverse polarity protection

Technical features

- Mounting via 2x M4 mounting screws (stainless steel)
- Operating voltage 24 V (18 ... 30 V)
- Transmission distance 0 - 3 mm
- Transmission of energy 24 V / 15 W
- Transmission of signals: 6 x PNP, 2 x Analog 0 - 10 V
- Connections:
 - Base: M12 x 1 male 12-pin
 - Remote: M12 x 1 female 12-pin
- Protection class: IP 67
- Id.No. Base: 0E012720 / Id.No. Remote: 0E012721

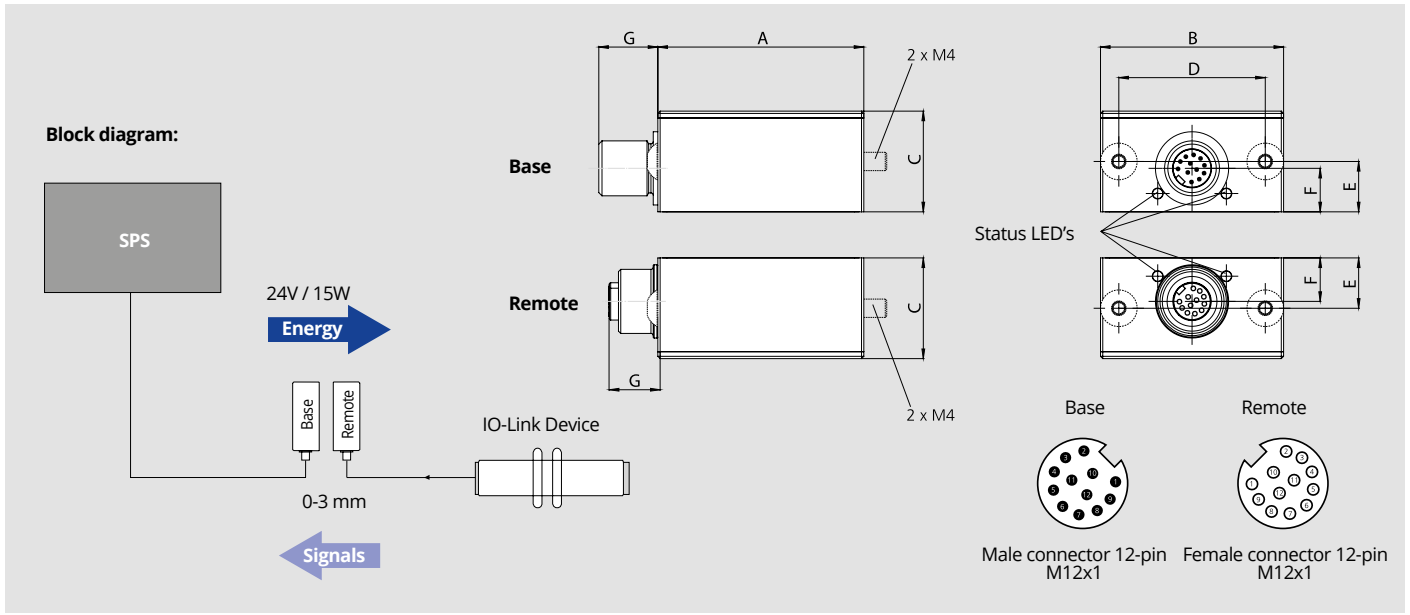

Inductive coupling system C40-IOI			
SMW-electronics Type		BASE	REMOTE
Id. No.		0E012720	0E012721
A	mm	45	45
B	mm	40	40
C	mm	22	22
D	mm	32	32
E	mm	11	11
F	mm	9.5	9.5
G	mm	13	10.6
H	mm	M12x1 / Male	M12x1 / Female
Housing material		AL	AL
Protection class		IP 67	IP 67
Operating temperature		-20° C ... +50° C	-20° C ... +50° C
Storage temperature		-20° C ... +80° C	-20° C ... +80° C
Transmission distance		0-3 mm	0-3 mm
Weight	kg	0.09	0.09
Operating voltage		24 V (18 ... 30 V)	-
Output voltage		-	24 V ± 10% DC
Power consumption (Base)		2000 mA	-
Power output (Remote)		-	625 mA
Overload protection / short circuit protection		-	-
Residual ripple		-	< 200 mV
Reverse polarity protection		-	-
Temperature monitoring		-	-
Data-Valid Output		150 mA	-
Ready delay		< 600 ms	< 600 ms
PIN assignment		SIGNALE BASE	SIGNALE REMOTE
Supply voltage	1	24 V IN	24 V OUT
Ground	2	GND	GND
Digital signal 1	3	0/24 V OUT	0/24 V IN
Digital signal 2	4	0/24 V OUT	0/24 V IN
Digital signal 3	5	0/24 V OUT	0/24 V IN
Digital signal 4	6	0/24 V OUT	0/24 V IN
Digital signal 5	7	0/24 V OUT	0/24 V IN
Digital signal 6	8	0/24 V OUT	0/24 V IN
Analog signal 1	9	0 ... 10 V OUT	0 ... 10 V IN
Analog signal 2	10	0 ... 10 V OUT	0 ... 10 V IN
	11	-	-
Data-Valid	12	DAV 24 V	-

Drawings and data are subject to change by SMW-Autoblok.

APPLICATION EXAMPLES

MX-L 520 with F180 ETHERNET inductive coupling system in robot application



2PXM-L 125 in robot application

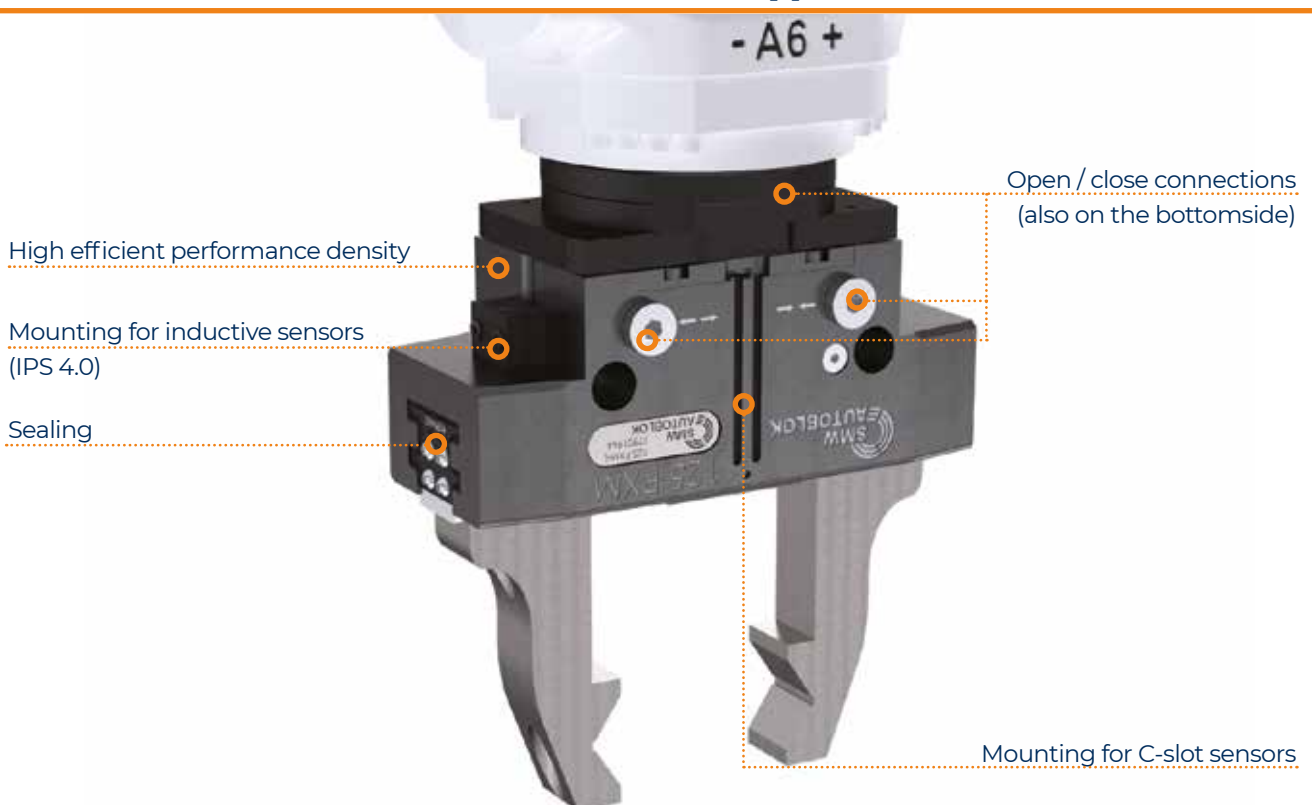

9

STORAGE and LOADING STATION Automation accessories

228

STORAGE WAREHOUSE

FOR SINGLE PALLET. Prepared for n.3 D350 max pallet for every plan.

230

STORAGE WAREHOUSE

FOR PALLET Q400. Prepared for n.2 pallet 500x500 for every plan

232

STORAGE PLANS

Single, Pallet, Q400 and vises.

236

LOADING STATION

D500: with one rotating unit casing a pallet D350.
D750: with a rotating unit Q400

240

ROBOTIZED AREA

STORAGE WAREHOUSE FOR SINGLE PALLET

prepared for n.3 D350 max pallet for every plan

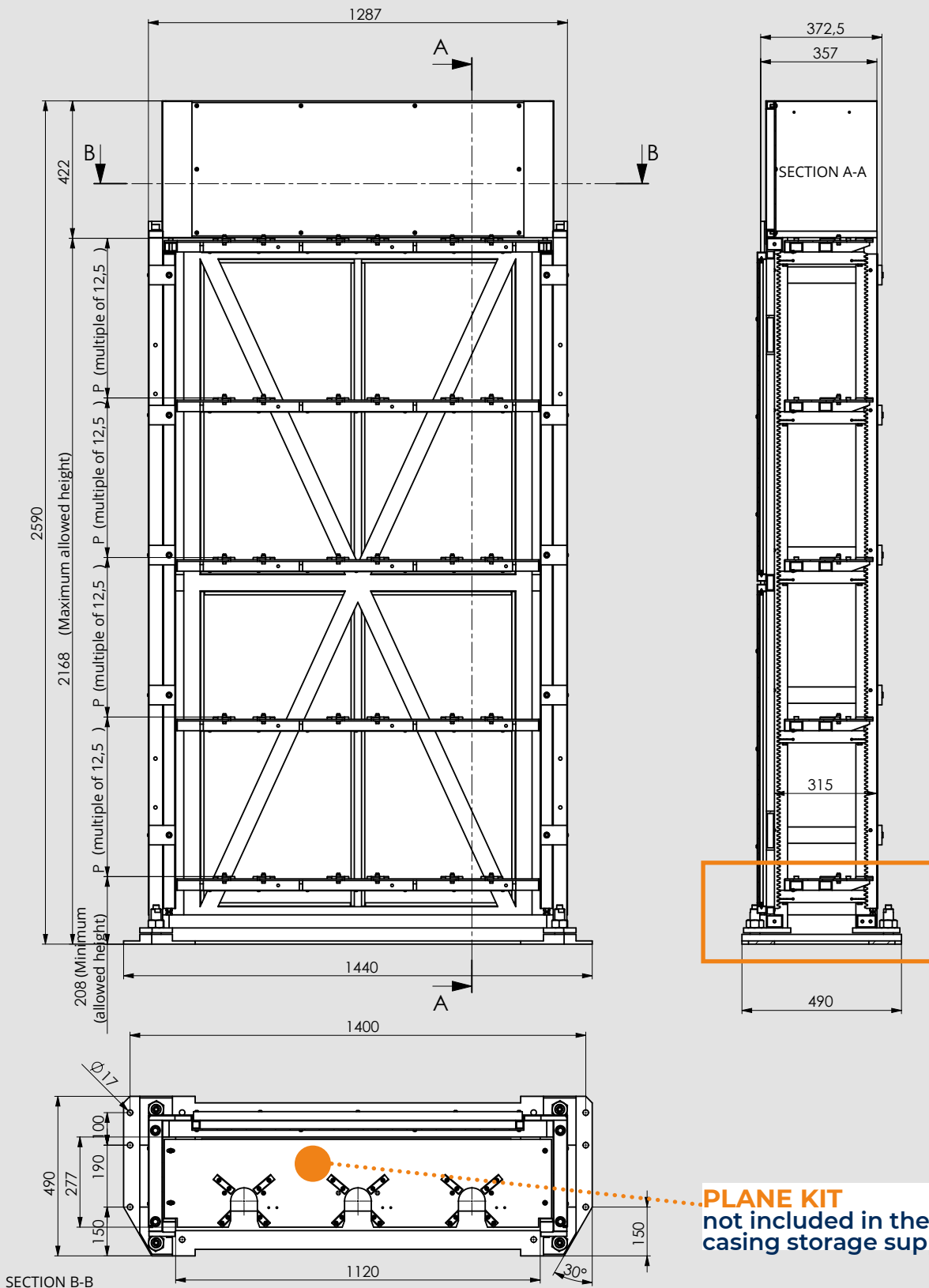

ID.N.	Note	Weight
46210049 STORAGE CASING 1120 X 315 DEPTH PALLET SINGLE	WITHOUT PLANS	400 Kg

STORAGE WAREHOUSE FOR SINGLE PALLET

prepared for n.3 D350 max pallet for every plan

ORDER GUIDE

THE COMPLETE STORAGE WAREHOUSE IS COMPOSED BY:

- N.1 STORAGE CASING 46210049
- + N.X PLANS KIT (AS NECESSARY)

THE STORAGE WAREHOUSE EXAMPLE DRAWING IS COMPOSED BY:

- N.1 STORAGE CASING 46210049
- + N.7 PLANS 46210030

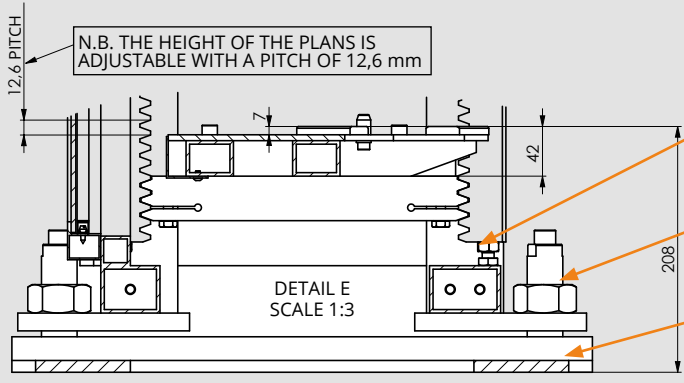
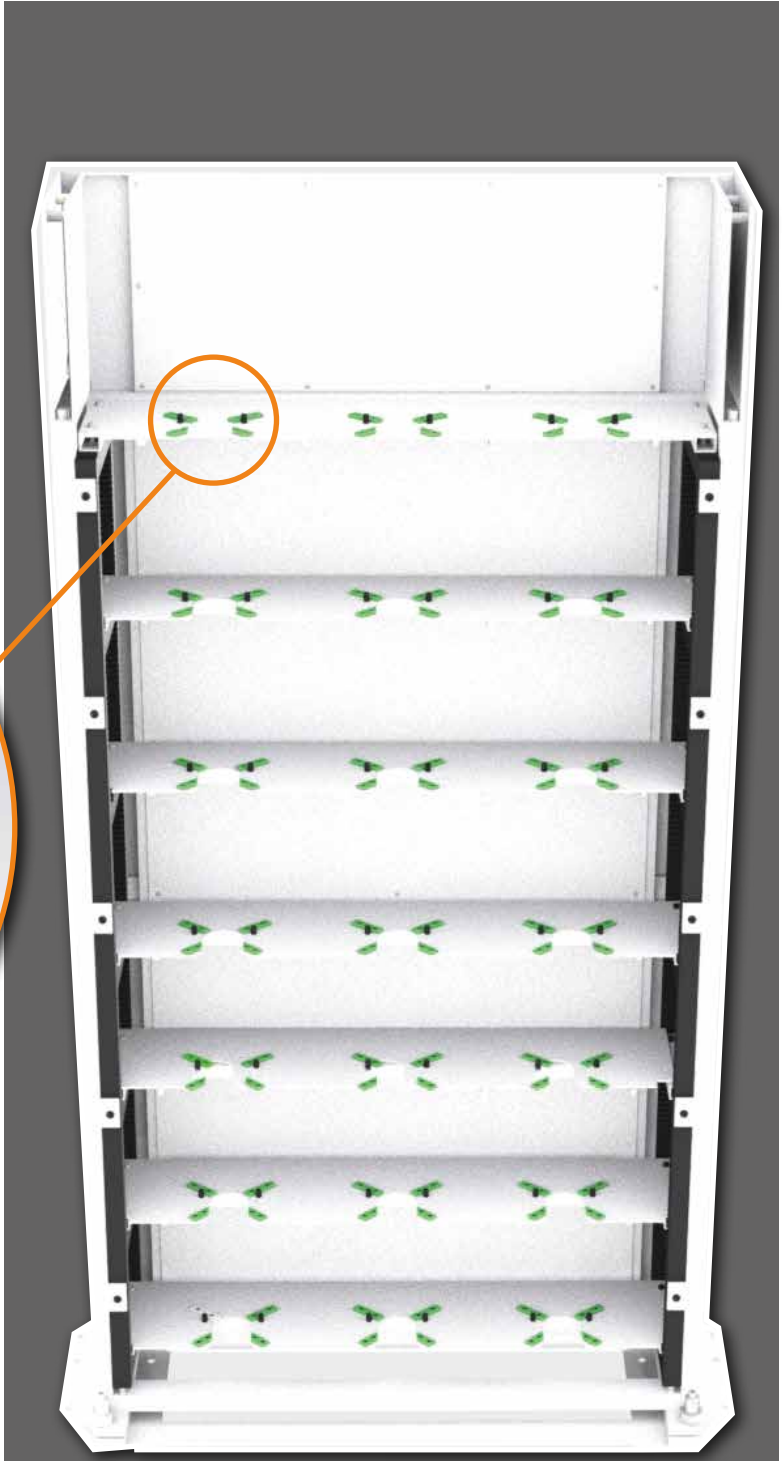

N.4 PLANS LEVEL FINE ADJUSTMENT

N.4 STORAGE WAREHOUSE LEVEL FINE ADJUSTMENT

N.1 FIXING PLATE ON THE FLOOR

Drawings and data are subject to change by SMW-Autoblok.

STORAGE WAREHOUSE FOR PALLET Q400
 prepared for n.2 pallet 500x500 for every plan

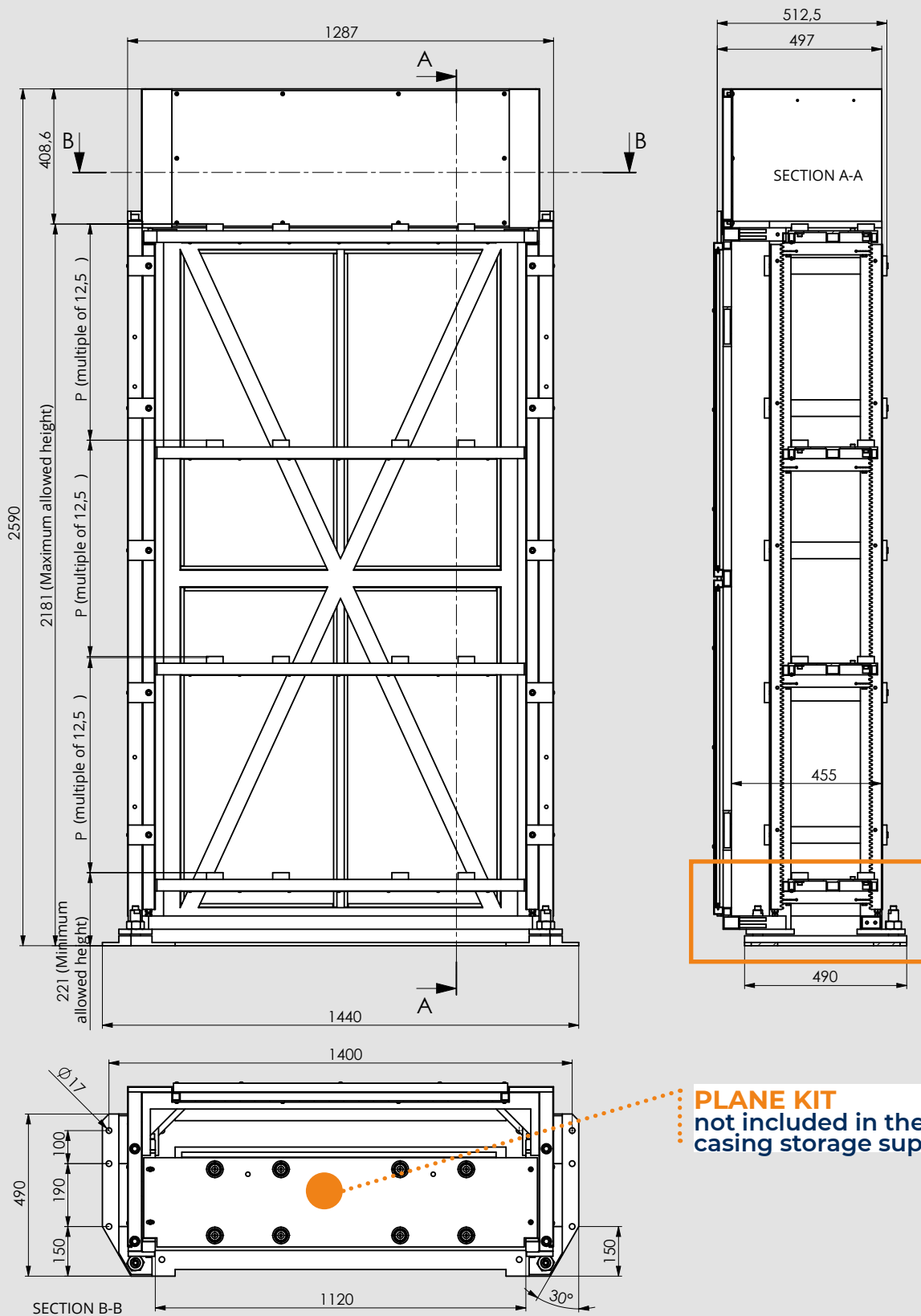

ID.N.	Note	Weight
46210069 STORAGE CASING 1120 X 455 DEPTH PALLET 500X500	WITHOUT PLANS	410 Kg

STORAGE WAREHOUSE FOR PALLET Q400
 prepared for n.2 pallet 500x500 for every plan

ORDER GUIDE

THE COMPLETE STORAGE WAREHOUSE IS COMPOSED BY:

- N.1 STORAGE CASING 46210069
- + N.X PLANS KIT (AS NECESSARY)

THE STORAGE WAREHOUSE EXAMPLE DRAWING IS COMPOSED BY:

- N.1 STORAGE CASING 46210069
- + N.5 plans 46210060
- (id n. for each plan)

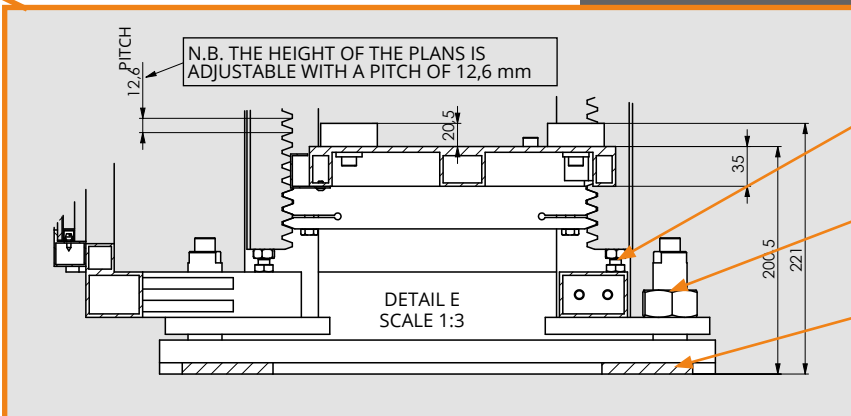
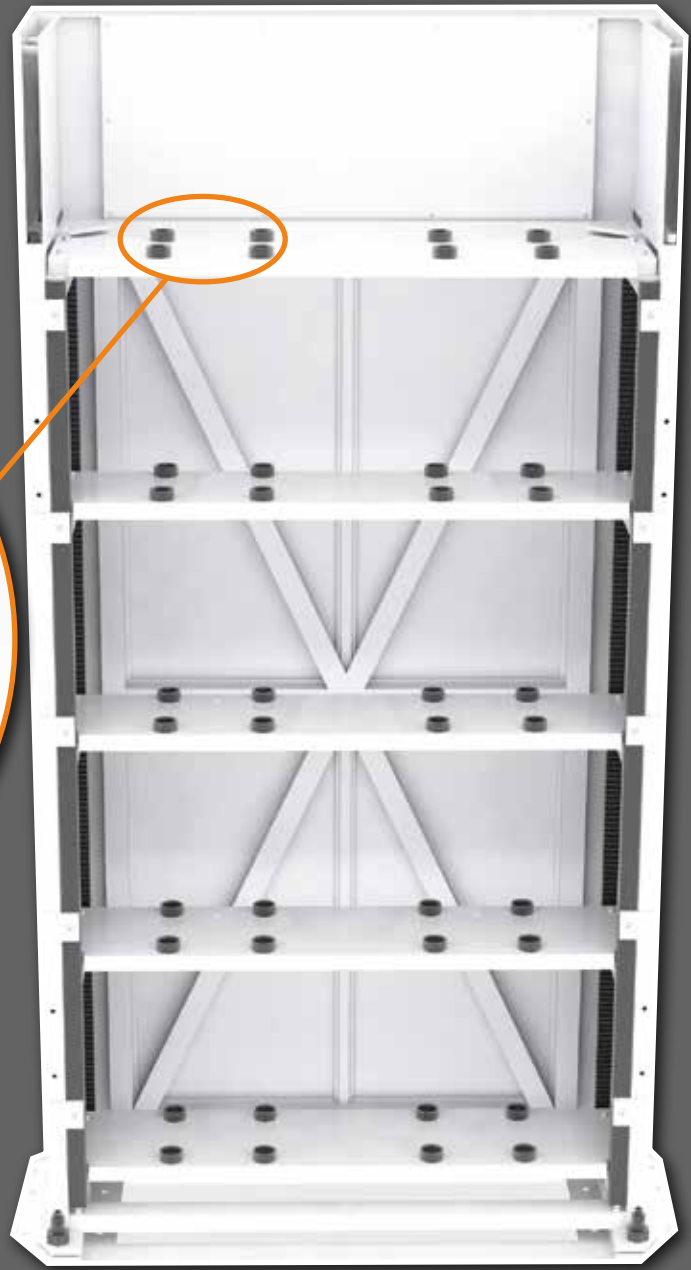
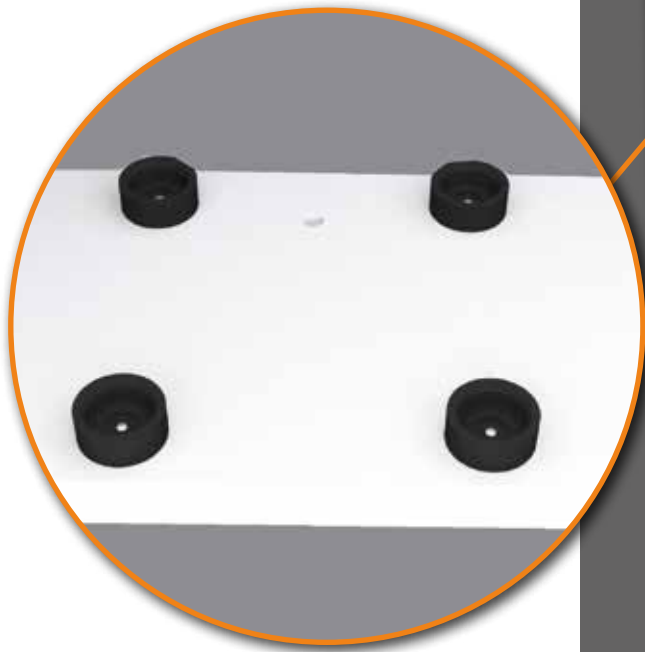

N.4 PLANS LEVEL FINE ADJUSTMENT

N.4 STORAGE WAREHOUSE LEVEL FINE ADJUSTMENT

N.1 FIXING PLATE ON THE FLOOR

Drawings and data are subject to change by SMW-Autoblok.

SINGLE PALLET STORAGE PLANS

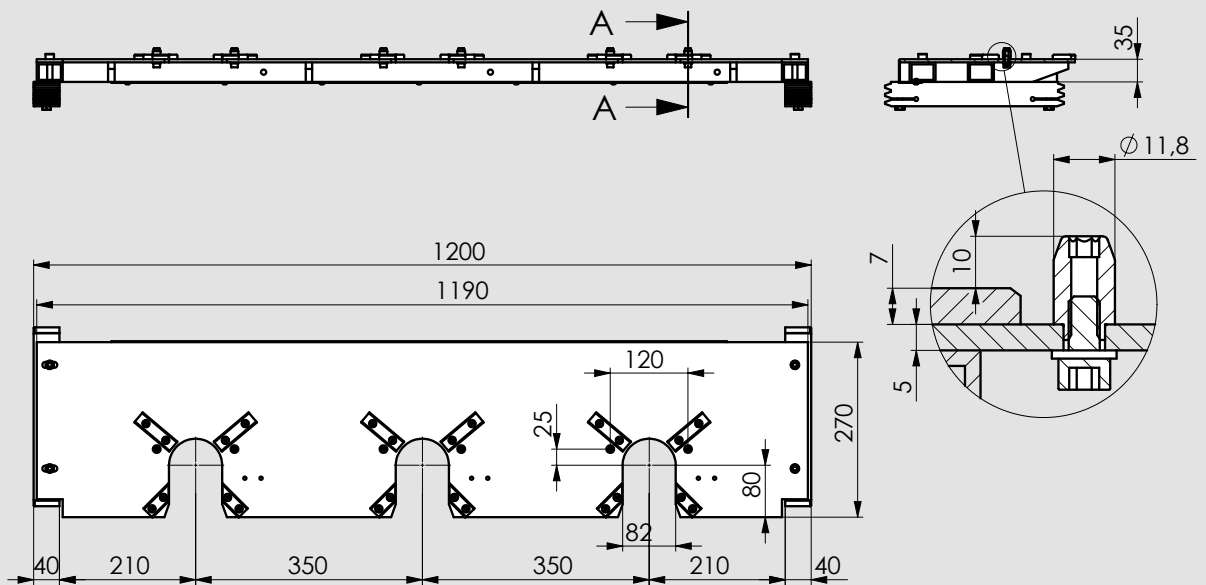

Plan to be used with storage warehouse 46210049

ID.N.	Maximum permitted weight for one pallet	Weight
46210030 PLAN KIT 3 PALLET APS140/APS190 INT.350	80 Kg	28 Kg

Chucks switching plan on the lathe

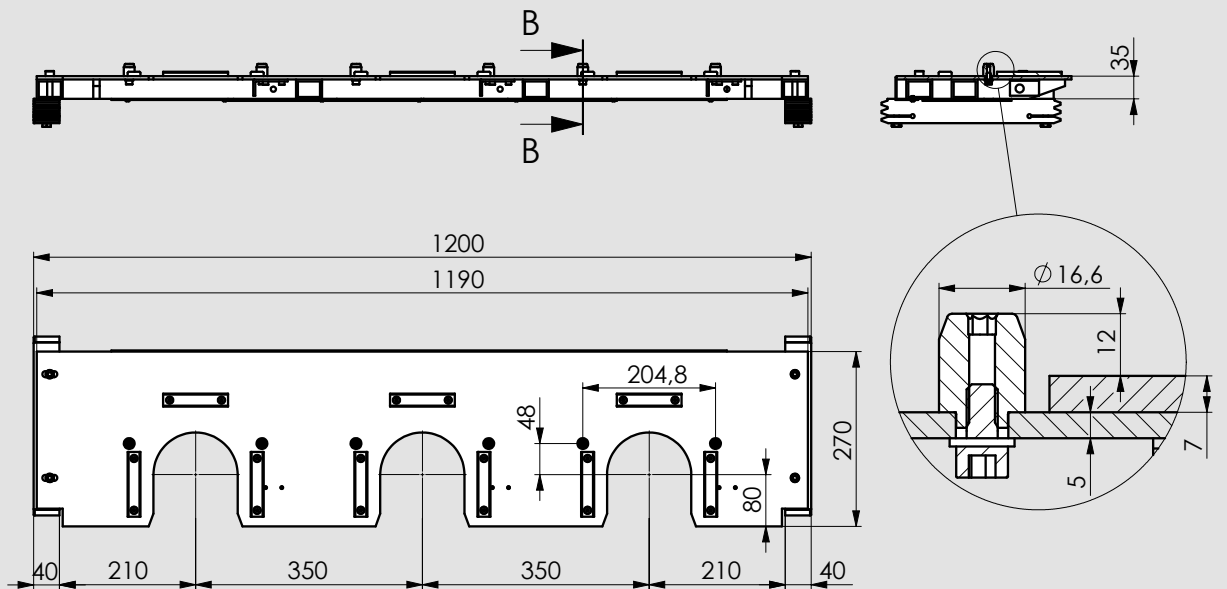

Plan to be used with storage warehouse 46210049

ID.N.	Maximum permitted weight for every pallet	Weight
46210120 PLANE KIT 3 PALLET APS250 INT.350	100 Kg	30 Kg

PALLET Q400 AND VISES STORAGE PLANS

125IMG e 160IMG vises plane

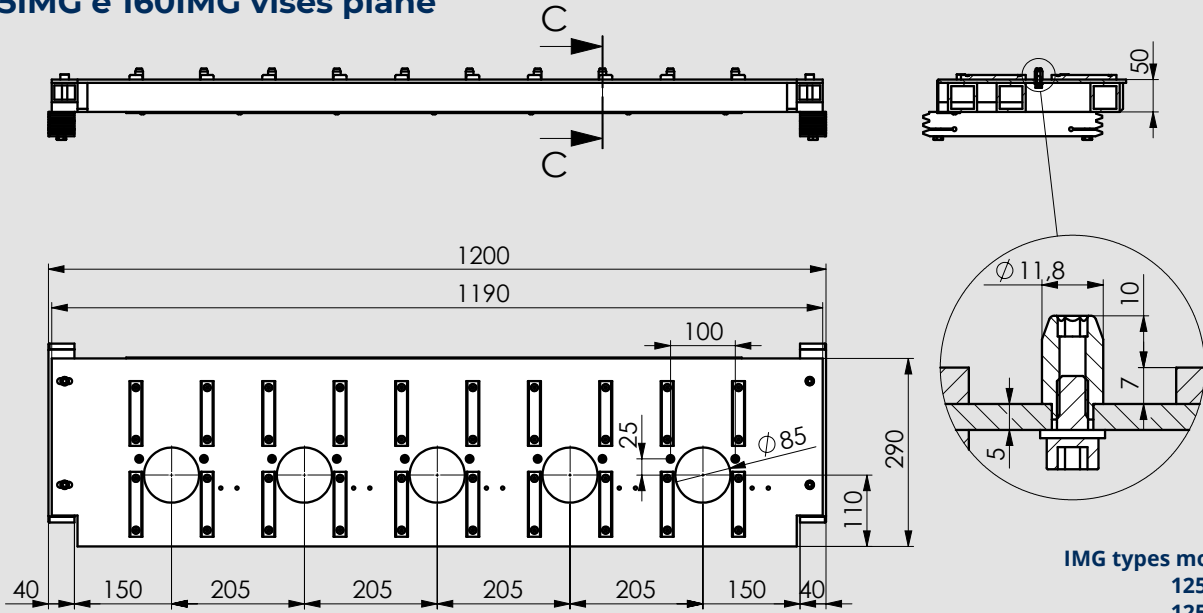

IMG types mountable:
 125 IMG-220
 125 IMG-320
 160 IMG-270

Plan to be used with storage warehouse 46210049

ID.N.	Maximum permitted weight for every position	Weight
46210110 PLAN KIT 5 125IMG/160IMG VISES INT.205	100 Kg	48 Kg

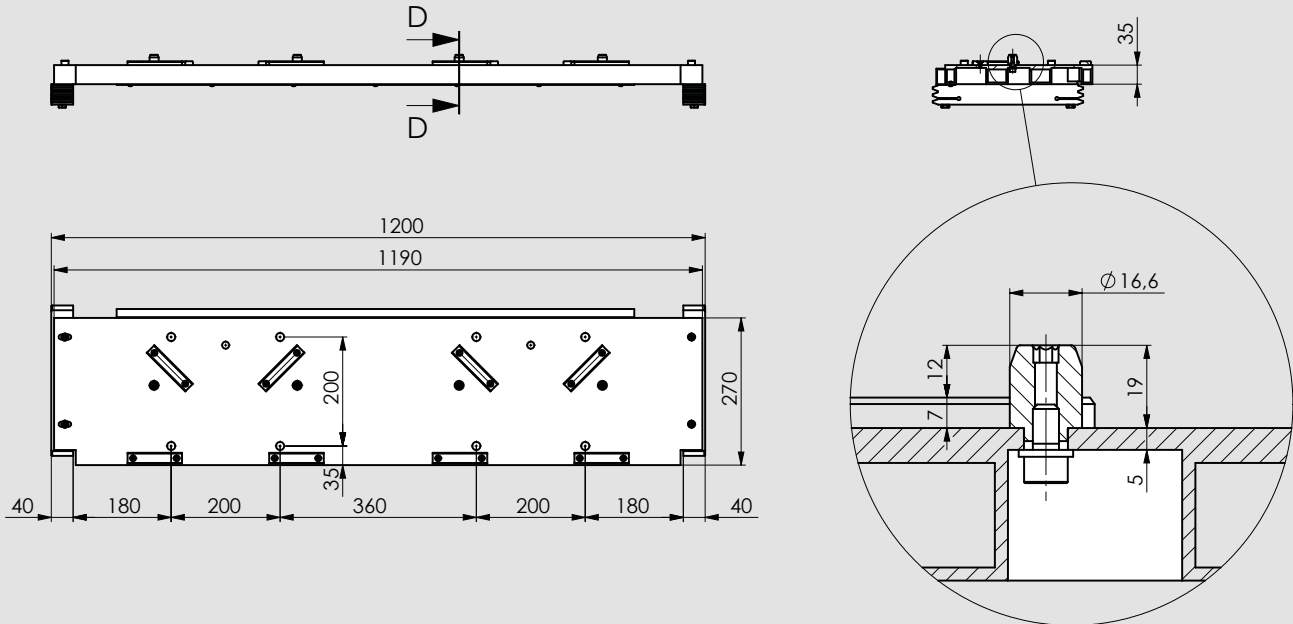

Plan to be used with storage warehouse 46210069

ID.N.	Pallet maximum dimension	Maximum permitted weight for every position	Weight
46210062 PLAN KIT 2 PALLET Q500 INT.560/200 for AT-PM	Ø400	200 Kg	34 Kg

PALLET STORAGE PLANS

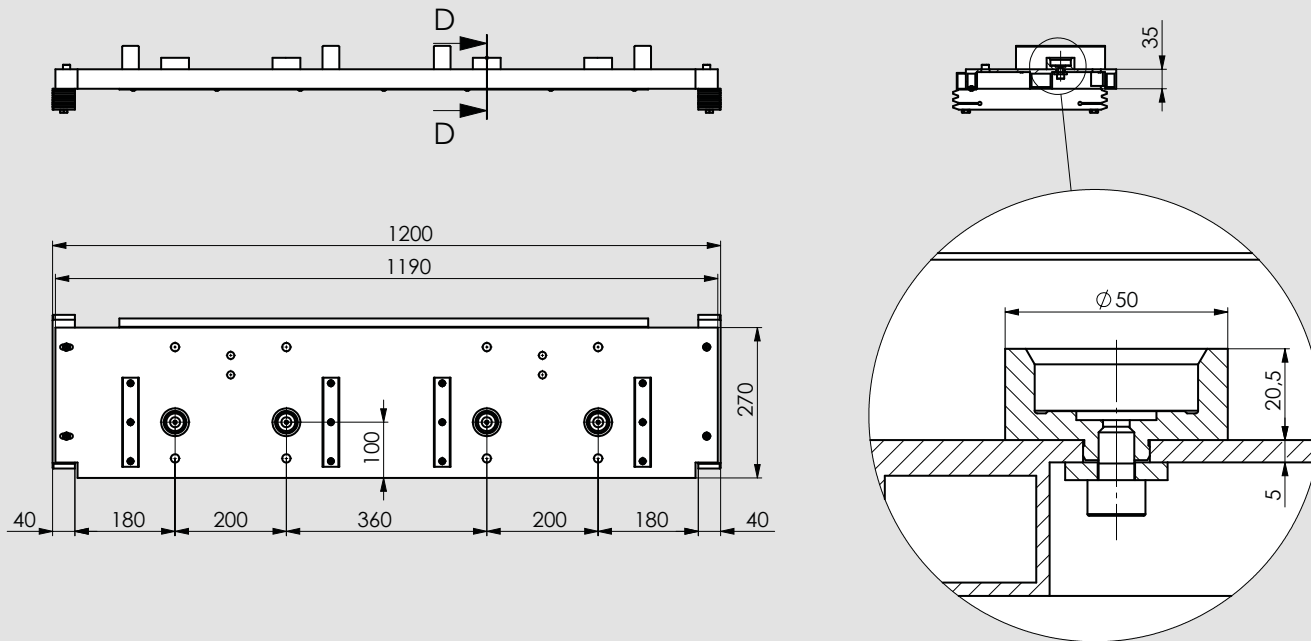

Plan to be used with storage warehouse 46210069

ID.N.	Pallet maximum dimension	Maximum permitted weight for every position	Weight
46210064 PLANE KIT 2 PALLET Q400 INT.560/200	250x500	200 Kg	31,5 Kg

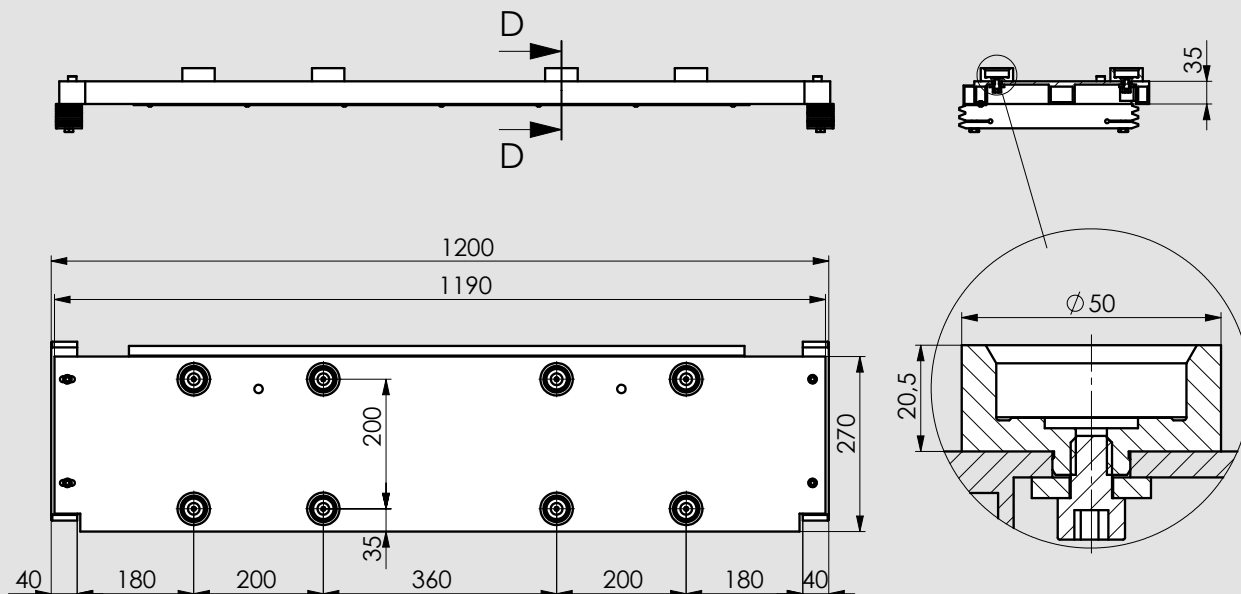

ID.N.	Pallet maximum dimension	Maximum permitted weight for every position	Weight
46210060 PLANE KIT 2 PALLET Q400 INT.560/200	500x500	200 Kg	31,5 Kg

Drawings and data are subject to change by SMW-Autoblok.

PALLET STORAGE PLANS

3
VISES

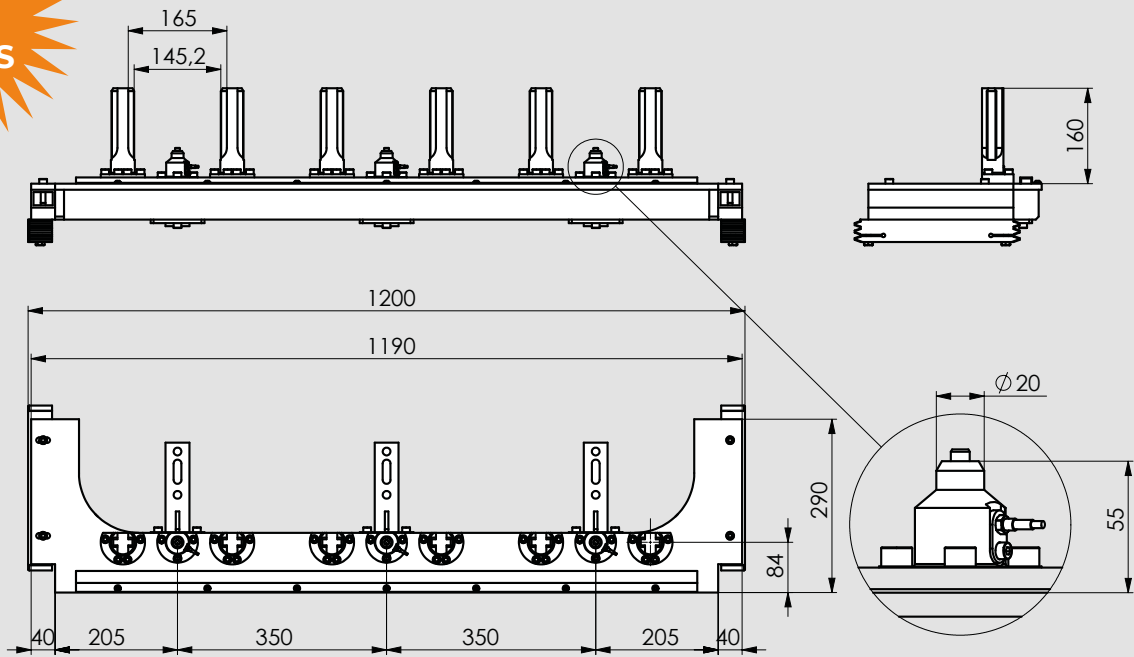

Plan to be used with storage warehouse 46210150

ID.N.	Maximum permitted weight for every position	Weight
46210145 PLAN KIT 3 VISES 160PRS INT.350	40 Kg	44,5 Kg

4
VISES

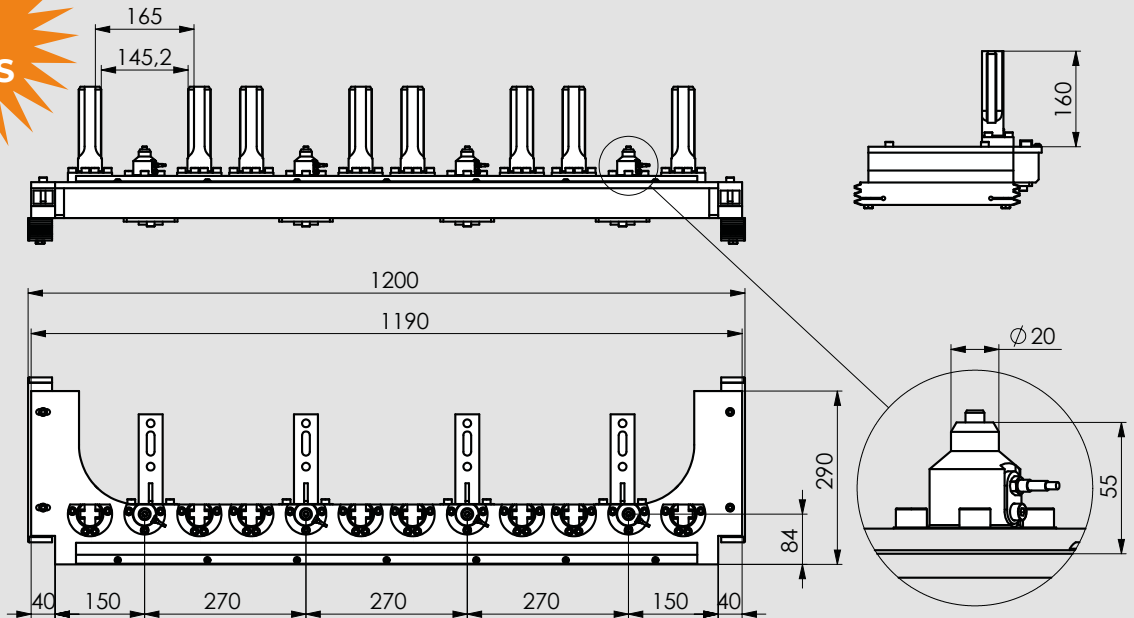

Plan to be used with storage warehouse 46210150

ID.N.	Maximum permitted weight for every position	Weight
46210146 PLAN KIT 4 VISES 160PRS INT.270	30 Kg	53 Kg

LOADING STATION D500 ID.N. 46212000
with one rotating unit casing a pallet D350 MAX with APS 190 pin mounting

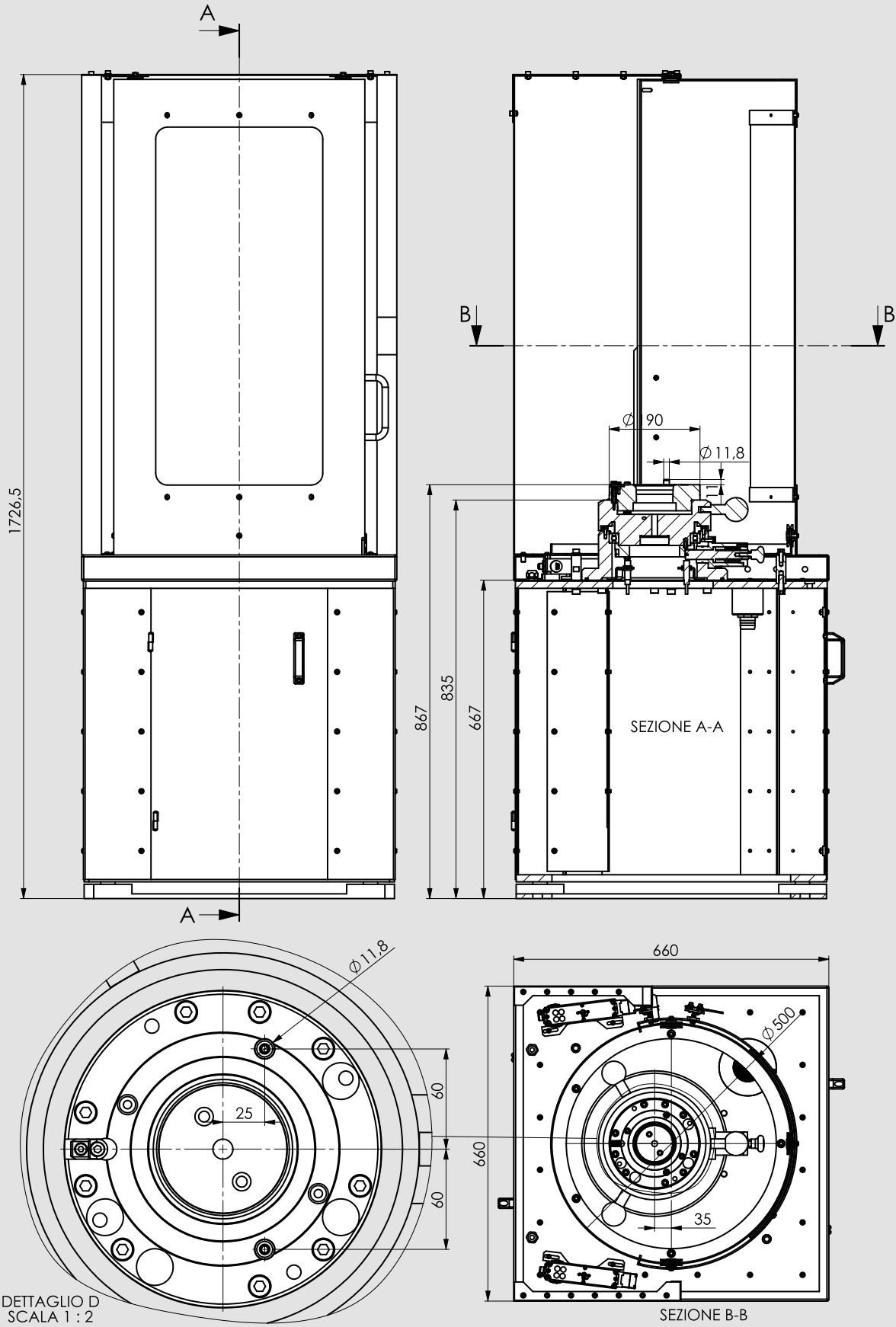

Id.n. (electric locks not included)

WEIGHT

46212000 LOADING STATION D500 + ROTATING UNIT PALLET APS 190 PIN

240 Kg

LOADING STATION D500 ID.N. 46212000

with one rotating unit casing a pallet D350 MAX with APS 190 pin mounting

Description:

The loading station D500 46212000 is composed by a base (with turning door) + one rotating unit with 4 fixed positions (4x90°).

On rotating unit can be mounted a pallet D350 max with a APS 190 pin mounting.

The loading station is designed to mount n.2 electric locks type EUCHNER (optional and not included inside the supply). These locks check the turning door opening and closing.

On request:

- On the rotating unit can be mounted pallet change systems different from APS 190.
- The rotating unit can be equipped with air sensing system and feedings both as option.
- For any customization contact the SMW-Autoblok technical office.

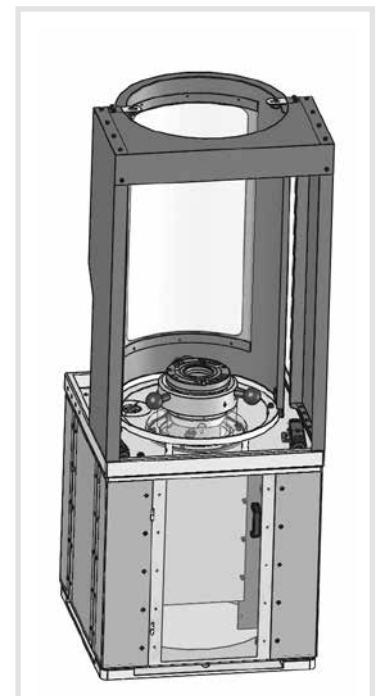
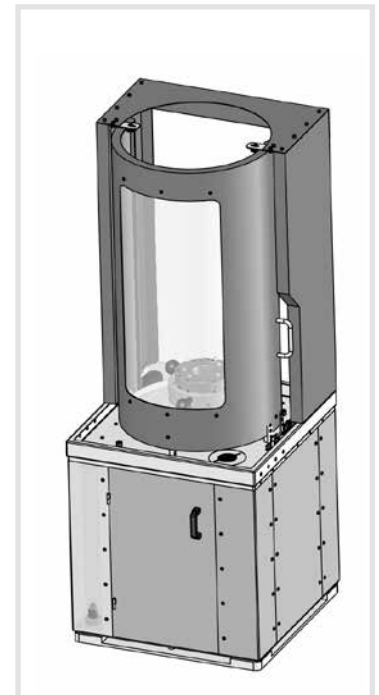
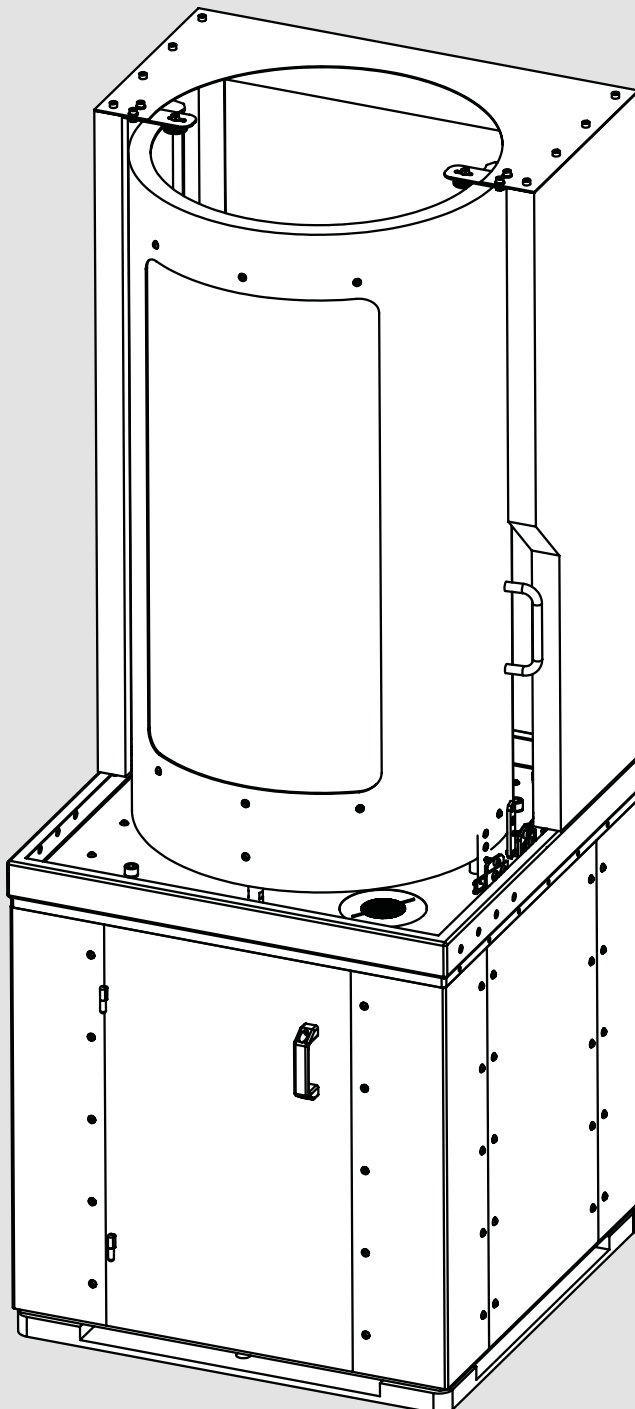

LOADING STATION D750 ID.N. 46212010
with a rotating unit Q400 4 APS wheelbase 200

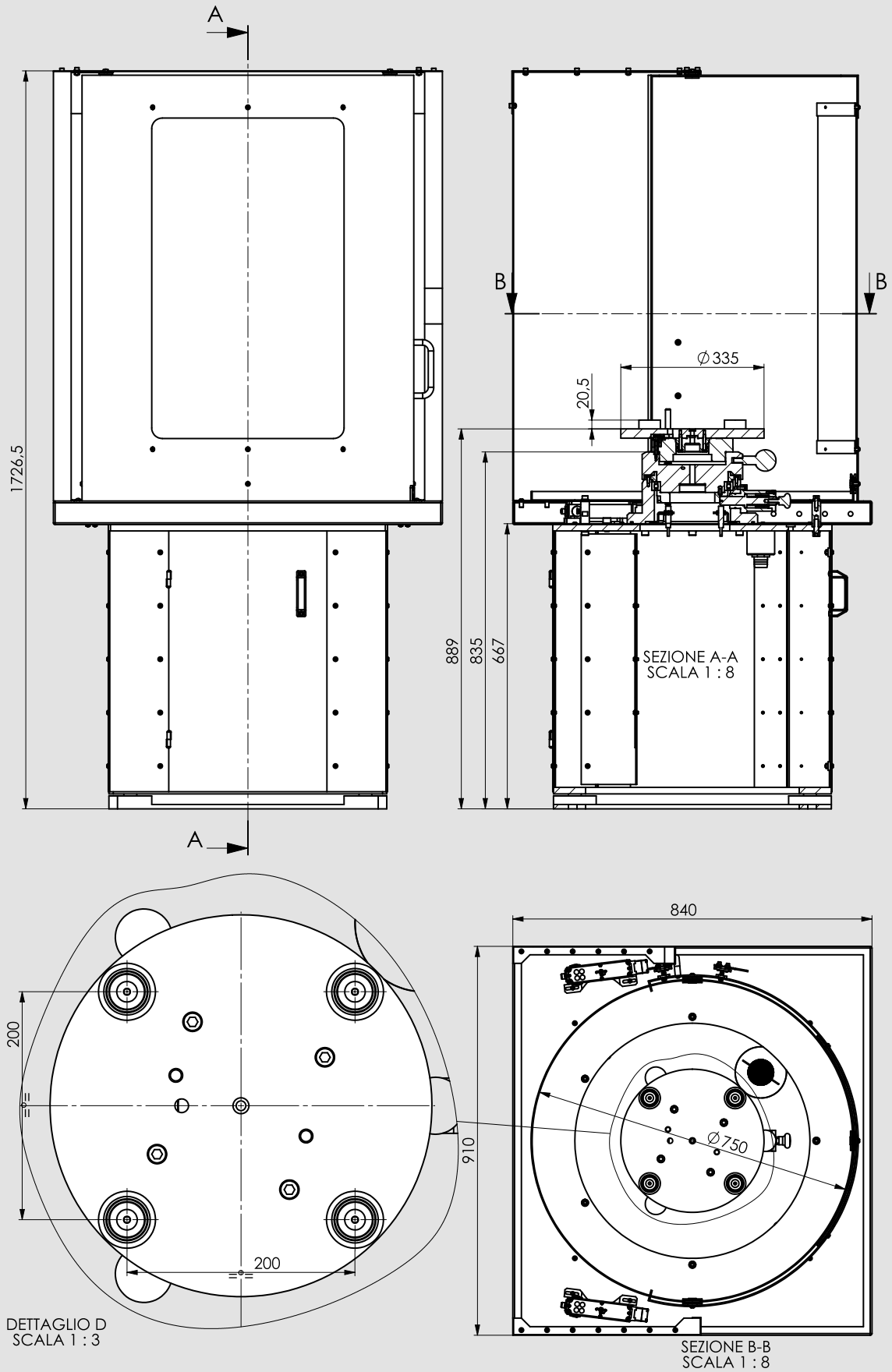

Id.n. (electric locks not included)

WEIGHT

46212010 LOADING STATION D750 + ROTATING PALLET UNIT Q400 4APS140 WHEELBASE 200

280 Kg

LOADING STATION D750 ID.N. 46212010 with a rotating unit Q400 4 APS wheelbase 200

Description:

The loading station D750 46212010 is composed by a base (with turning door) + one rotating unit with 4 fixed positions (4x90°).

On rotating unit can be mounted a pallet Q400 with mounting 4APS140 wheelbase 200.

The loading station is designed to mount n.2 electric locks type EUCHNER (optional and not included inside the supply). These locks check the turning door opening and closing.

On request:

- On the rotating unit can be mount Q400 or D560 pallet change systems different from 4 APS 140 wheelbase 200.
- The rotating unit can be equipped with air sensing system and feedings both as option.
- For any customization contact the SMW-Autoblok technical office.

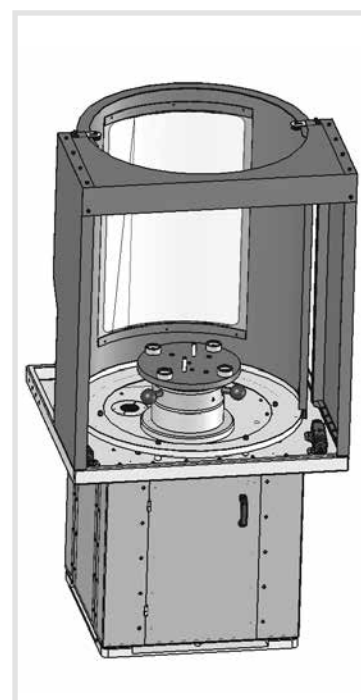
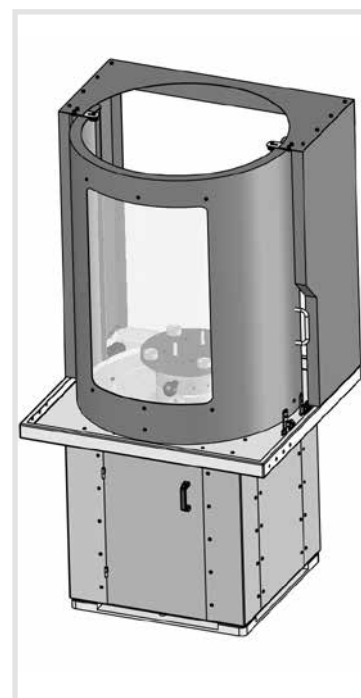
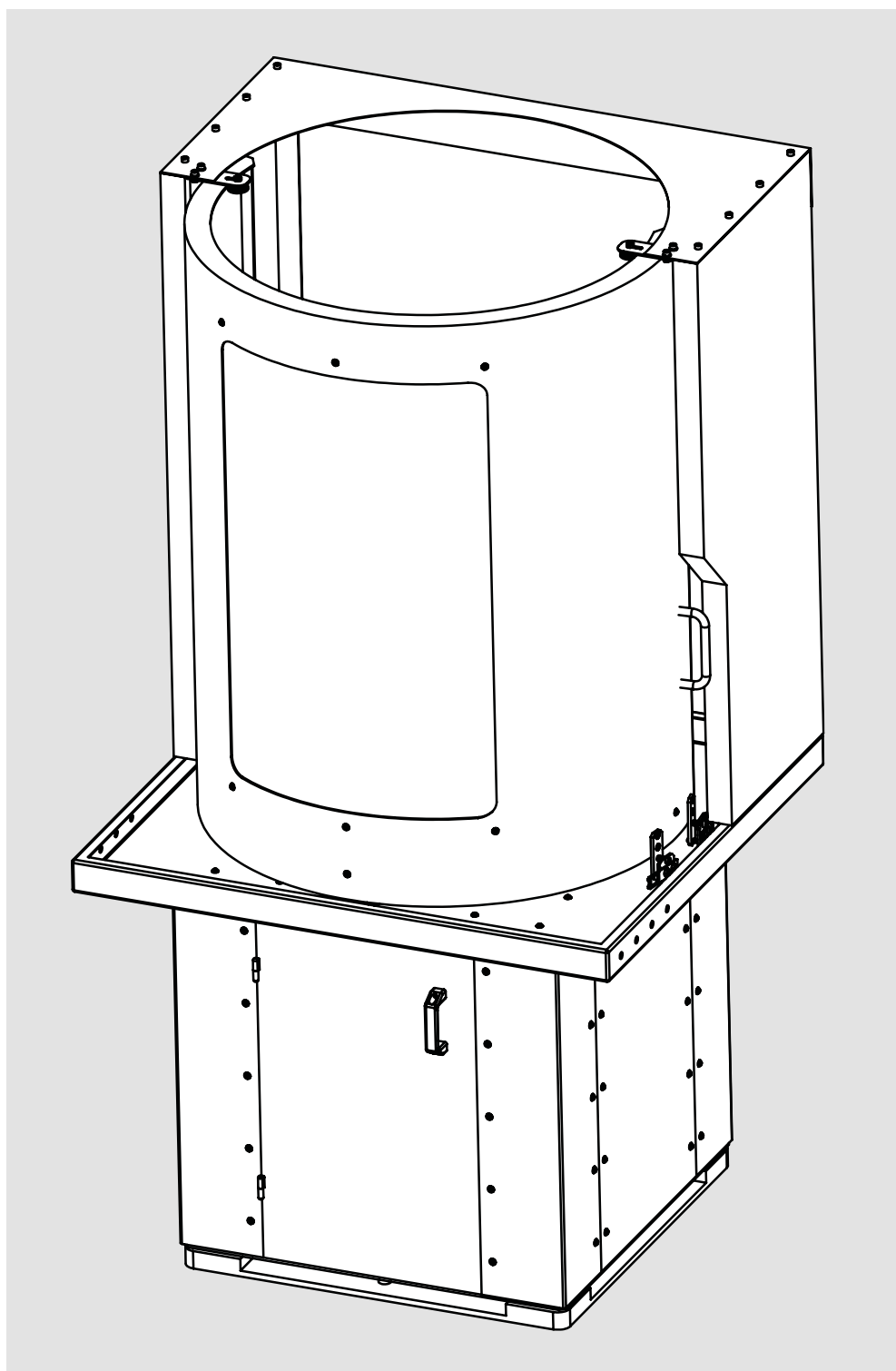

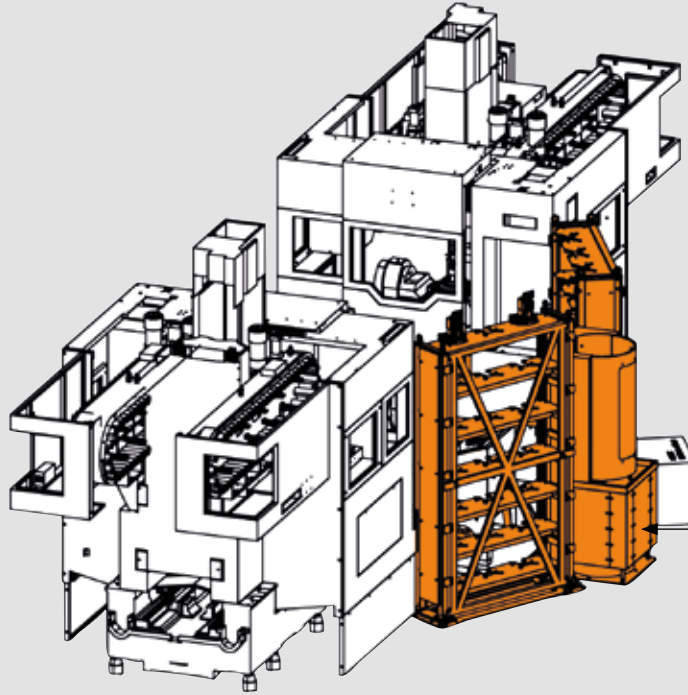

Loading station
46212000

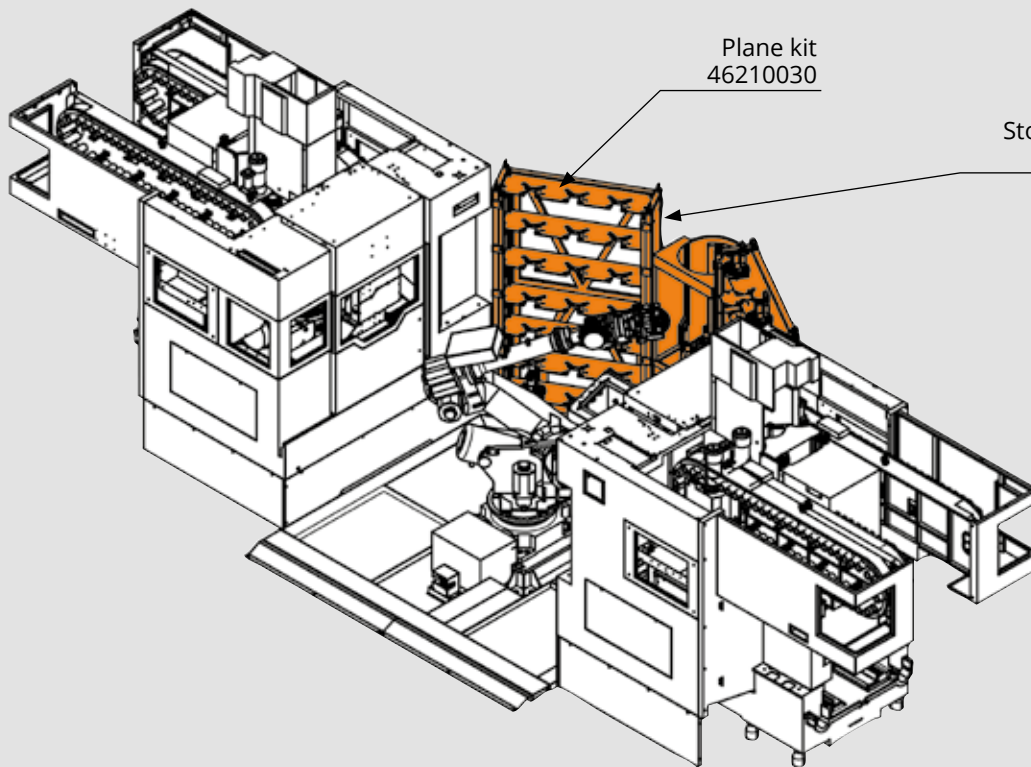

Plane kit
46210030

Storage casing
46210049

**SMW-AUTOBLOK Spannsysteme GmbH**

Postfach 1151 • D-88070 Meckenbeuren
 Wiesentalstraße 28 • D-88074 Meckenbeuren
 Tel. +49 (0) 7542 - 405 - 0

Vertrieb Inland: Fax +49 (0) 7542 - 3886
 E-mail: vertrieb@smw-autoblok.de

Sales International: Fax: +49 (0) 7542 - 405 - 181
 E-mail: sales@smw-autoblok.de

**AUTOBLOK s.p.a.**

Via Duca D'Aosta n.24
 I-10040 Caprie - Torino
 Tel. +39 011 - 9638411 Fax +39 011 - 9632288

E-mail: info@smwautoblok.it

CUSTOMER'S APPLICATION FOR STATIC WORKHOLDING

Z.I. P.zza Alessandro Volta, snc I- 86038 Petacciato (CB)
 Tel. +39 0875 670001

**U.S.A.**

SMW-AUTOBLOK Corporation
 285 Egidi Drive - Wheeling, IL 60090
 Tel. +1 847 - 215 - 0591
 Fax +1 847 - 215 - 0594
 E-mail: autoblok@smwautoblok.com

**France**

SMW-AUTOBLOK
 17, Avenue des Frères Montgolfier - Z.I Mi-Plaine
 F-69680 Chassieu
 Tel. +33 (0) 4 - 727 - 918 18
 Fax +33 (0) 4 - 727 - 918 19
 E-mail: autoblok@smwautoblok.fr

**Japan**

SMW-AUTOBLOK Japan Inc.
 1-56 Hira, Nishi-Ku
 461-Nagoya
 Tel. +81 (0) 52 - 504 - 0203
 Fax +81 (0) 52 - 504 - 0205
 E-mail: japan@smwautoblok.co.jp

**Great Britain**

SMW-AUTOBLOK Telbrook Ltd.
 7 Wilford Industrial Estate
 Ruddington Lane, Wilford
 GB-Nottingham, NG11 7EP
 Tel. +44 (0) 115 - 982 1133
 E-mail: info@smw-autoblok-telbrook.co.uk

**China**

SMW-AUTOBLOK (Shanghai) Work Holding Co.,Ltd.
 Building 1, N.141 Xuanchun Road, Pudong District
 201399, Shanghai, P. R. China
 Tel. +86 21 - 5810 - 6396
 Fax +86 21 - 5810 - 6395
 E-mail: china@smwautoblok.cn

**Spain**

SMW-AUTOBLOK IBERICA, S.L.
 Ursalto 4 - Pab. 9-10 Pol. 27
 20014 Donostia - San Sebastián (Gipuzkoa)
 Tel. +34 943 - 225 079
 Fax +34 943 - 225 074
 E-mail: info@smwautoblok.es

**Mexico**

SMW-AUTOBLOK Mexico, S.A. de C.V.
 Acceso III No. 16 Int.9
 Condominio Quadrum
 Industrial Benito Juarez
 Querétaro, Qro. C.P. 76130
 Tel. +52 (442) 209 - 51 18
 Fax +52 (442) 209 - 5121
 E-mail: smwmex@smwautoblok.mx

**Canada**

SMW AUTOBLOK CANADA CORP
 1460 The Queensway - Suite 219
 Etobicoke, ON M8Z 1S7
 E-mail: info@smwautoblok.ca

**India**

SMW-AUTOBLOK Workholding Pvt. Ltd.,
 Plot No. 4, Weikfield Industrial Estate,
 Gat No. 1251, Sanaswadi, Tal - Shirur,
 Dist - Pune. 412 208
 Tel. +91 2137 - 616 974
 Fax +91 2137 - 616 972
 E-mail: info@smwautoblok.in

**Taiwan**

AUTOBLOK Company Ltd.
 NO.6, SHUYI RD., SOUTH DIST.,
 TAICHUNG, TAIWAN
 Tel. +886 4-226 10826
 Fax +886 4-226 12109
 E-mail: taiwan@smwautoblok.tw

**Poland**

SMW-AUTOBLOK POLAND SP. Z O.O
 Stalowa 17,
 41-506 Chorzów
 Tel. +48 736 059 699
 E-mail: info@smwautoblok.pl

**Czech Republic**

SMW-AUTOBLOK s.r.o.
 Merhautova 20
 CZ - 613 00 BRNO
 Tel. +420 513 034 157
 Fax +420 513 034 158
 E-mail: info@smw-autoblok.cz

**Turkey**

SMW-AUTOBLOK MAKİNA SAN. VE TİC. LTD. ŞTİ.
 Yenişehir Mah, Osmanlı Blv,
 Volume Kurtköy Ofis, No:9, Kat:2,
 D:30, PK: 34912, Pendik, İstanbul
 Tel. + 90 216 629 20 19
 E-mail: info@smwautoblok.com.tr

**Sweden / Norway / Denmark**

SMW-AUTOBLOK Scandinavia AB
 Kommendörsgatan 3
 SE-281 35 Hässleholm
 Tel. +46 (0) 761 420 111
 Tel. +46 (0) 761 420 440
 E-mail: info@smw-autoblok.se

**Korea**

SMW-AUTOBLOK KOREA CO., LTD.
 1502-ho, 44, Charyong-ro 48beon-gil,
 Uichang-gu, Changwon-si,
 Gyeongsangnam-do, 51391, Republic of Korea
 Tel. +82 55 264 9505
 E-mail: info-korea@smw-autoblok.net