

Clamping of easy deformed / thin walled workpieces

High precision 6 jaw chucks (2+2+2) equalising

Tongue & groove

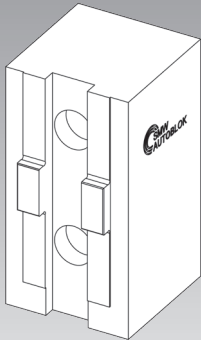

Metric serration



SJL-C/-M 225-400

SJL-C 500-800

SJLS-C/-M 225-400

proofline® series
fully sealed – low maintenance

2+2+2 equalising

Is clamping with 6 jaws, where always 2 jaws are equalising as a pair. This allows to compensate inaccuracy of the workpiece roundness. The grip force is always distributed equally onto 6 jaws. The equal distribution of the grip forces results in a minimum of deformation.

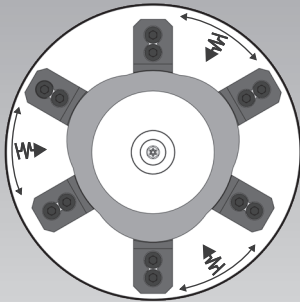

Application for:

Raw material clamping (1. Operation)

6 jaw self centering

Is clamping concentric with all 6 jaws, where no equalisation is done during clamping. All 6 jaws make the same radial movement towards the chucks center.

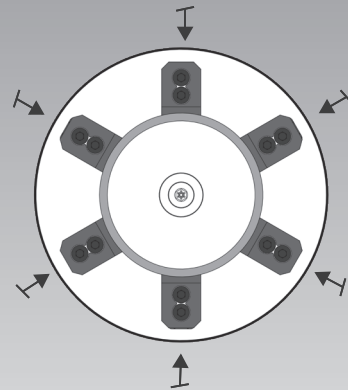

Application for:

Round, machined clamping diameters (2. Operation)

Centrifugal force compensation

The centrifugal forces of master- and top jaws are compensated by counter balance weights. The centrifugal forces of the jaws under rotation are mostly compensated.

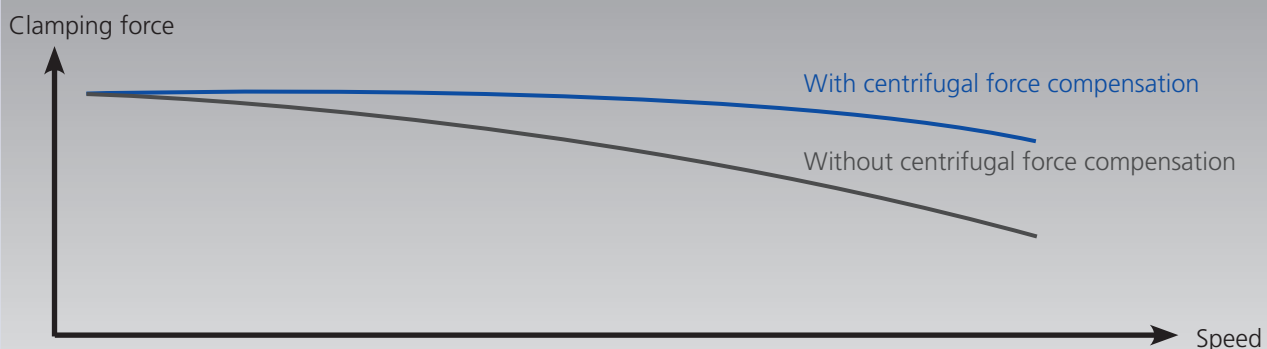

Clamping glossary

2+2+2 Equalisation: A system which allows 2 jaws in a pair to do a different radial jaw stroke. On raw material clamping the system ensures that all 6 jaws are in contact with the workpiece. The grip force is distributed onto all 6 jaws and reduces the deformation of the workpiece.

Locking system for 6 jaw self centering: **SJL chuck** have a locking system that allows to lock the 2+2+2 equalisation. In this setting the **SJL chuck** can be used like a standard 6 jaw chuck with 6 concentric jaws. This setting can be used to clamp thin walled workpieces that need an equal wall thickness.

Air sensing: Air is fed through the contact face of the work stop. When the workpiece is in contact with the work stop, the airflow is stopped and converts into a signal. If the component is not correctly positioned or is lifted, the machine can not start or the spindle is stopped. The preparation of this important feature is standard on all **SJL type** chucks.

Centrifugal force compensation: When jaw chucks are rotating, the mass of the master jaws / top jaws is subject to centrifugal force. This centrifugal force reduces the dynamic grip force, and thus limits the feeds and speeds for machining.

All **SJL chuck** have a centrifugal force compensation system built in by default which reduces this effect and allows machining at higher speed with more aggressive feed rates.

Chuck body reinforcement: When the chucks are rotating, the chuck body has to prop up against the static grip force and against the centrifugal force caused by the rotation speed. On 6 jaw chucks, the centrifugal force caused by the jaws is the double compared to 3 jaw chucks. In order to increase the stiffness of the chuck body, **SJL chucks** have a reinforcement on the chuck body.

High-low clamping: For easily deformed components. High gripping forces for the rough cut are reduced to low gripping forces for the finish cut without unchucking. This means less deformation on the finished components. Contrarily to conventional chucks, the **SJL lever drive** is suitable for high-low clamping.

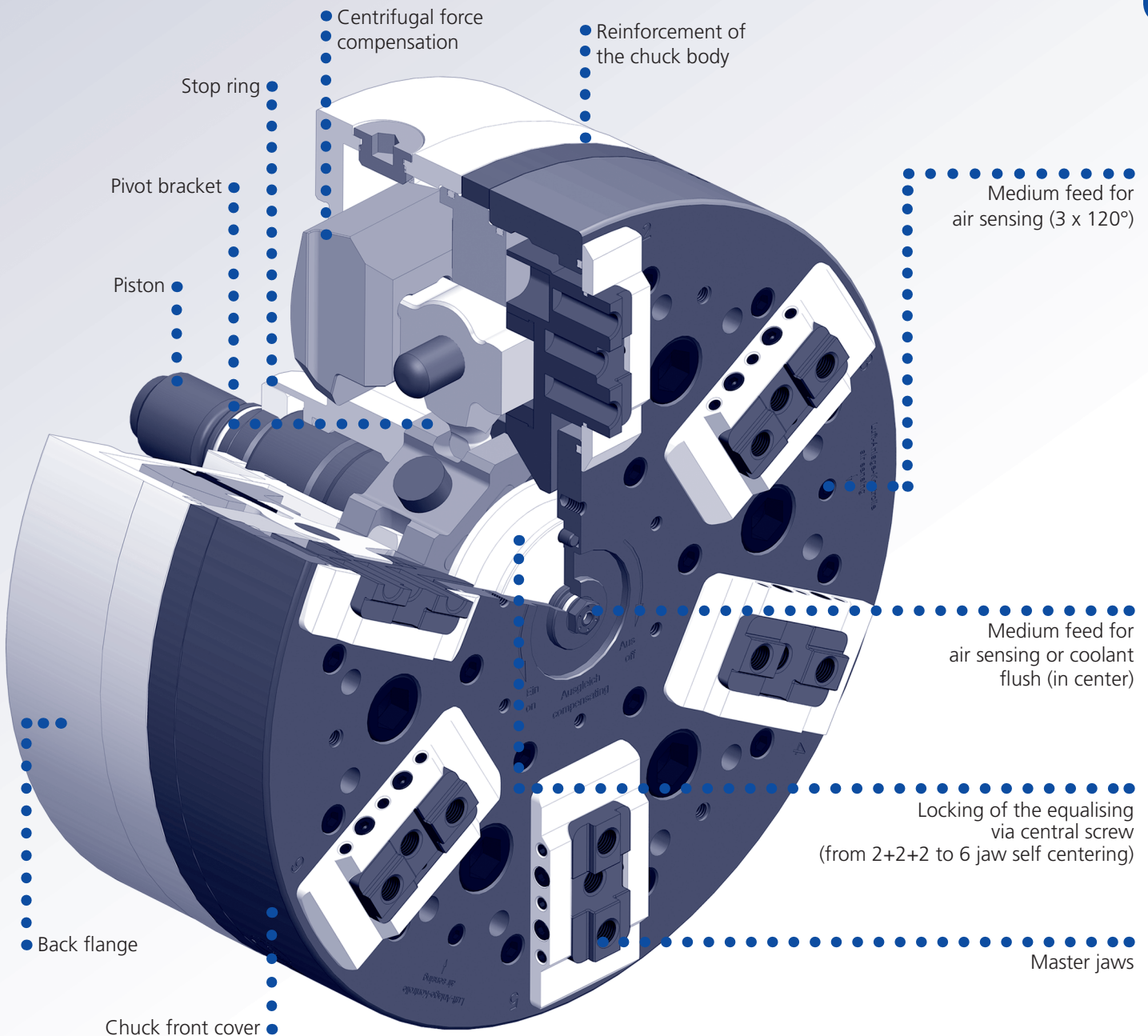

SJL-C

Self centering
TONGUE & GROOVE

SJL-M

Self centering
METRIC SERRATION

High precision 6 jaw chucks (2+2+2) equalising Ø 225 - 400 mm

- Jaws equalising as a pair
- Equalising mechanism lockable



proofline® series
fully sealed – low maintenance

Application/customer benefit

- Clamping of easy deformed workpieces
- Low deformation by means of 2+2+2 jaw clamping
- High radial and axial clamping accuracy
- Fully sealed and oil bath lubricated
- Ideal for high speeds

Technical data

- Adjustable to 6 jaw 2+2+2 or true 6 jaw clamping
- Channels for air and / or coolant (2 medium feed)
- Centrifugal force compensation
- **proofline® chucks** = fully sealed - low maintenance

Standard equipment

6 jaw chuck with mounting bolts and adjustment key
Oil

Chuck in open position = right end position

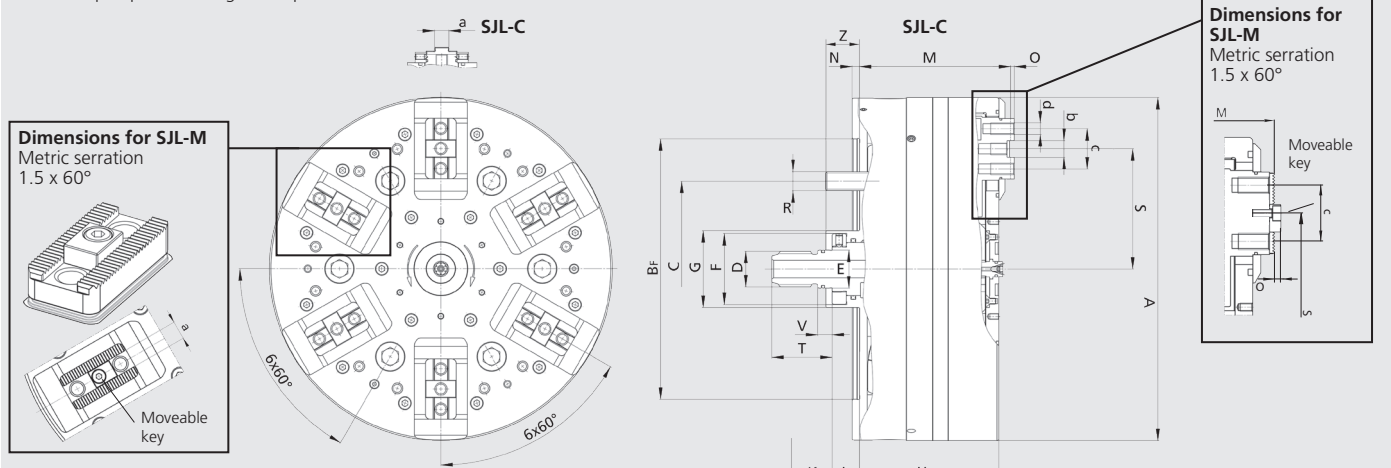

Subject to technical changes.
For more detailed information please ask our customer service.

SMW-AUTOBLOK Type			SJL-C-225	SJL-M-225	SJL-C-290	SJL-M-290	SJL-C-400	SJL-M-400
Mounting			Z170	Z170	Z220	Z220	Z300	Z300
	A	mm	225	225	290	290	400	400
	Bf H6	mm	170	170	220	220	300	300
	C	mm	133.4	133.4	171.4	171.4	235	235
	D	mm	M24	M24	M30	M30	M42x3	M42x3
	E f7	mm	25	25	32	32	44	44
	F	mm	47	47	60	60	82	82
	G	mm	51	51	65	65	90	90
	H	mm	93	93	118	118	163	163
Piston stroke	K	mm	11.5	11.5	15	15	20.8	20.8
Piston position min.	L	mm	18	18	23	23	30.9	30.9
Piston position max.	L	mm	29.5	29.5	38	38	51.7	51.7
	M	mm	101	103.5	128	131	177	181
	N	mm	5	5	6	6	8	8
	O	mm	2.5	3	3	3.5	4	3.5
	R	mm	M12 (6 x 60°)	M12 (6 x 60°)	M16 (6 x 60°)	M16 (6 x 60°)	M20 (6 x 60°)	M20 (6 x 60°)
Max.	S	mm	79	79	101.5	101.5	139	139
Min.	S	mm	73	73	93.5	93.5	128	128
	T	mm	40	40	51	51	70	70
	V	mm	10	10	12.2	12.2	17	17
Protecting sleeve length	Z	mm	22.1	22.1	28.1	28.1	38.1	38.1
Key width	a	mm	10	10	12	12	14	14
	b	mm	11	-	14	-	19	-
	c	mm	27 (2 x 13.5)	27 (2 x 13.5)	34 (2 x 17.0)	33 (2 x 16.5)	45 (2 x 22.5)	45 (2 x 22.5)
	d	mm	M8 (3x)	M8 (3x)	M10 (3x)	M10 (3x)	M12 (3x)	M12 (3x)

High precision 6 jaw chucks (2+2+2) equalising Ø 225 - 400 mm

- Jaws equalising as a pair
- Equalising mechanism lockable

SJL-C

Self centering
Tongue & groove

SJL-M

Self centering
Metric serration

Technical data

SMW-AUTOBLOK Type		SJL-C-225	SJL-M-225	SJL-C-290	SJL-M-290	SJL-C-400	SJL-M-400
Stroke per jaw	mm	6	6	8	8	11	11
Equalising stroke at mid of jaw stroke	mm	±1	±1	±1	±1	±2.5	±2.5
Max. actuating force	kN	30	30	42	42	58	58
Max. gripping force	kN	45	45	65	65	90	90
Max. Speed	r.p.m.	4200	4200	3600	3600	2600	2600
Weight (without top jaws)	kg	26	26	51	51	136	136
Moment of inertia	kg·m ²	0.16	0.16	0.5	0.5	2.75	2.75

Order review

SMW-AUTOBLOK Type	SJL-C-225	SJL-M-225	SJL-C-290	SJL-M-290	SJL-C-400	SJL-M-400
Mounting	Z170	Z170	Z220	Z220	Z300	Z300
Id. No.	160870	160922	160670	160940	160970	161001
Hex. Pin type socket wrench	202881		201064		203795	
Oil (RENOLIN CLPF 320 SUPER) 1 liter			202532			

Top jaws for SJL

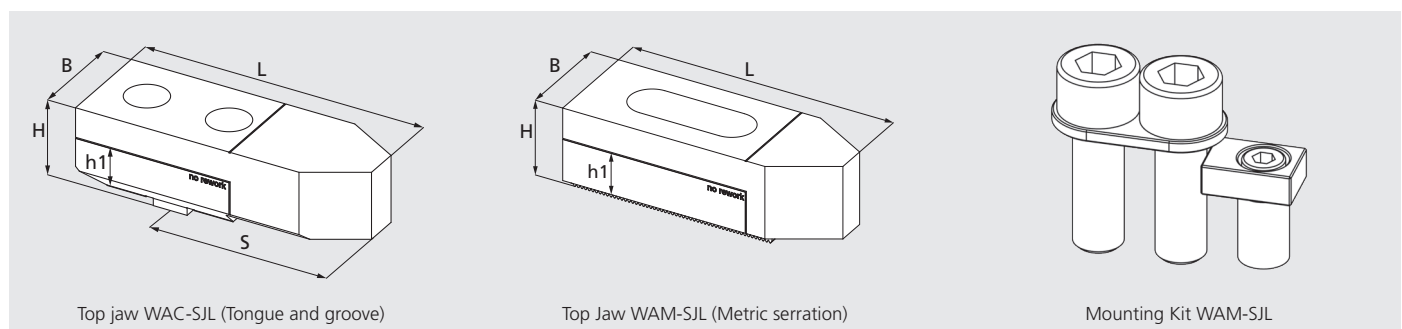

SMW-AUTOBLOK Type	WAC-SJL-225	WAM-SJL-225	WAC-SJL-290	WAM-SJL-290	WAC-SJL-400	WAM-SJL-400
Id. No. / set	5300950	539053	5300955	539055	5301053	5301052
Mounting Kit (only WAM) / set	-	203572	-	203573	-	204115
Dimensions L x B x H	94 x 20 x 32	84 x 20 x 32	115 x 40 x 36	108 x 40 x 35	150 x 52 x 46	153 x 52 x 46
Height h1	16.5	20	21	22	25	26.5
Weight / set	2.2 kg	1.8 kg	5.4 kg	4.9 kg	12.5 kg	12.5 kg
S (mm)	63.5	-	80	-	105.5	-

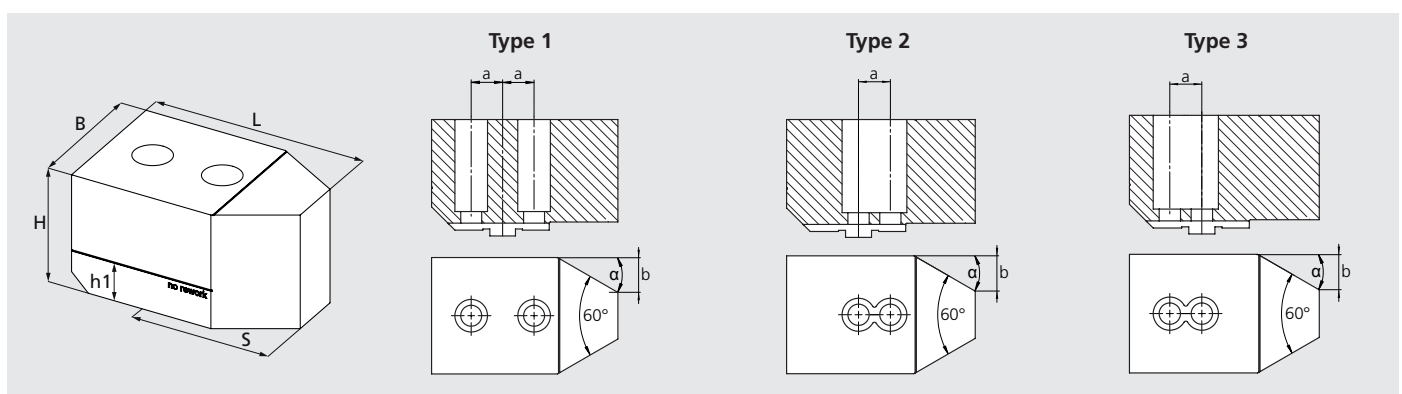

SMW-AUTOBLOK Type	WAC-SJL-225			WAC-SJL-290			WAC-SJL-400		
Jaw type	Type 1	Type 2	Type 3	Type 1	Type 2	Type 3	Type 1	Type 2	Type 3
Id. No. / set	5316471	5316472	5316473	5316468	5316469	5316470	5316465	5316467	5316466
Thread	M8			M10			M12		
Dimensions L x B x H	80 x 50 x 50			100 x 60 x 65			140 x 80 x 65		
Height h1	18.5			21			25		
Weight / Set	7			13.5			25.2		
S	49.5			65			95.5		
a	13.5			17			22.5		
b x α	15 x 30°			20 x 30°			28 x 30°		

* No rework.