

■ Stahl geschliffen

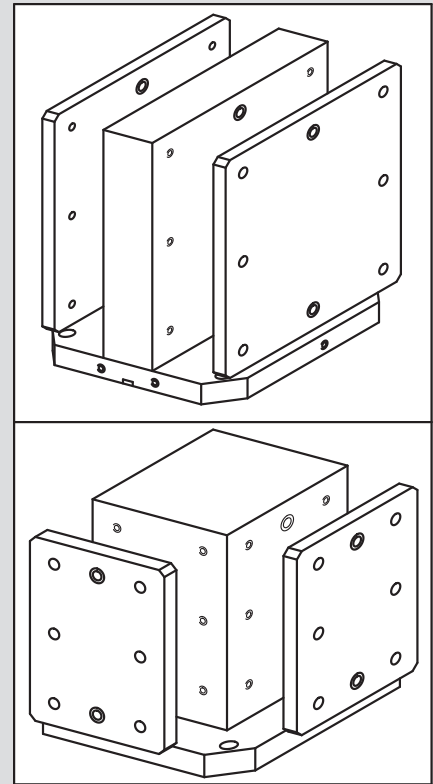
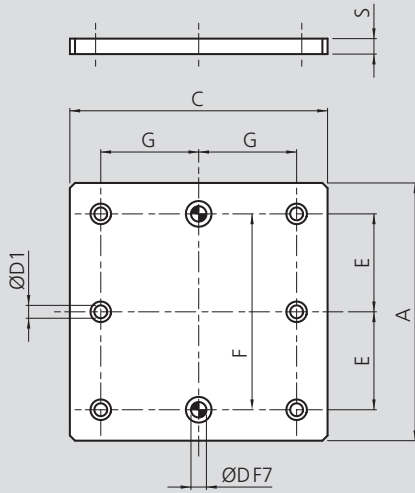

Technische Änderungen vorbehalten.

Wechselplatten – STAHL

Id.-Nr.	C [mm]	A [mm]	Ø D [mm]	Ø D1 [mm]	E [mm]	F [mm]	G [mm]	S [mm]	Gewicht [kg]
57120025	160	400	12	11	150	300	40	20	10
57120090	250	600	16	13	250	500	75	25	29
57120130	350	600	16	13	250	500	125	25	41
57120155	400	600	16	13	250	500	150	25	47
57120175	450	800	16	13	350	700	175	25	70.5
57120195	500	600	16	13	250	500	200	25	58.5
57120210	550	800	16	13	350	700	225	25	86
57120235	630	800	16	13	350	700	250	25	98.5
57120250	800	800	16	13	350	700	350	30	149

Sonderausführungen auf Anfrage.

- Stahl geschliffen
- Mit Bohrungsrastrer

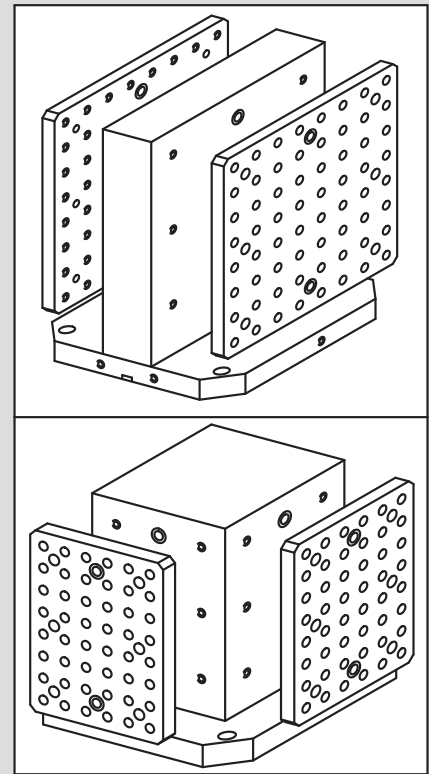
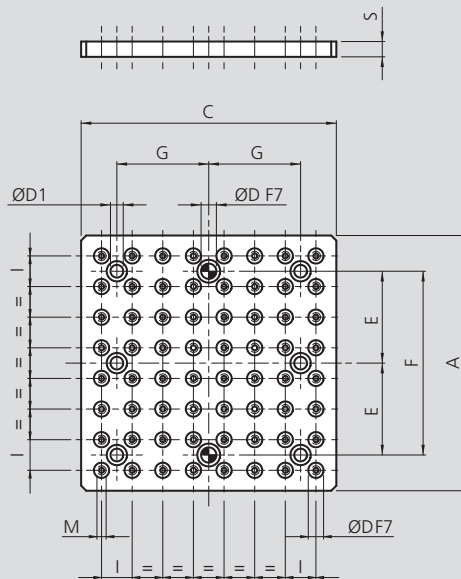

Technische Änderungen vorbehalten.

Rasterplatten – STAHL

Id.-Nr.	C [mm]	A [mm]	Ø D [mm]	Ø D1 [mm]	M	E [mm]	F [mm]	G [mm]	I [mm]	S [mm]	Gewicht [kg]
57050025	160	400	12	11	M10	150	300	40	40	30	15
57050090	250	600	16	13	M12	250	500	75	50	35	39
57050130	350	600	16	13	M12	250	500	125	50	35	55
57050155	400	600	16	13	M12	250	500	150	50	35	63
57050175	450	800	16	13	M12	350	700	175	50	35	95
57050195	500	600	16	13	M12	250	500	200	50	35	78
57050210	550	800	16	13	M12	350	700	225	50	35	114
57050235	630	800	16	13	M12	350	700	250	50	35	131
57050250	800	800	16	13	M12	350	700	350	50	35	166

Sonderausführungen auf Anfrage.