

MJ STAND ALONE VERSION

To be mounted on the table or on the pallet of the FMS/machine. Economical and relatively compact and light.



MJP PALLET VERSION

MJ mechanism inbuilt in the machine pallet for the most compact and light solution. To be developed with the cooperation of the machine manufacturer.

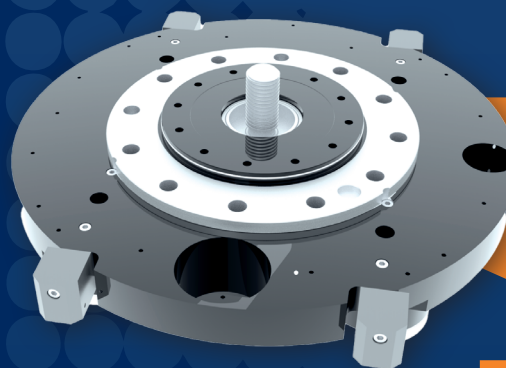

MJC CARTRIDGE VERSION

MJ mechanism in a cartridge to be inserted partially or completely in the machine pallet by the machine manufacturer in a specially designed pallet. Possibility to adapt the cartridge to the needs of the machine manufacturer.

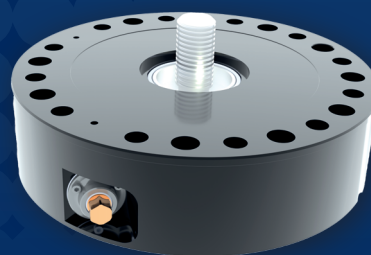

MJ**Manual Jack to operate a power chuck with Ø300-520 Plain Back**

STAND ALONE

■ Ø300/390 - Ø520/750

**Application/customer benefits**

- Equipment of machining centers to manually operate a power chuck
- Ideal for 5 axis tuning-milling machines without air/oil feed
- Ideal for palletized machines due to mechanical irreversible constant gripping force
- Better alternative to a manual chuck thanks to the use of power chucks
- To operate any type of power chuck: 2/3/4 jaws, 2+2, 6 jaws, 2+2+2 etc.
- Best with sealed power chucks of the SMW-Autoblok Proofline series
- The large variety of SMW-Autoblok power chucks allow the customer to clamp the workpiece with the best chuck alternatives
- No need of air/oil feeds making it a perfect solution for pallet changing systems
- Easily interchangeable among several machines
- Easily adaptable to the machine table/pallet with different centering and mounting threads patterns
- To operate chucks in both external and internal clamping

Technical features

- Irreversible mechanism based on an operating screw driven by a worm gear
- With spring energy storage for safe clamping
- Sealed mechanism and constantly lubricated
- Very low profile and possibility to integrate it in the machine pallet
- Low operating torque to reach the desired pull force (depending on the chuck)

Standard equipment

Manual jack, depending on the application with customized centering and base flange

Order Example

Manual Jack MJ 380/480 part nr. 97003802

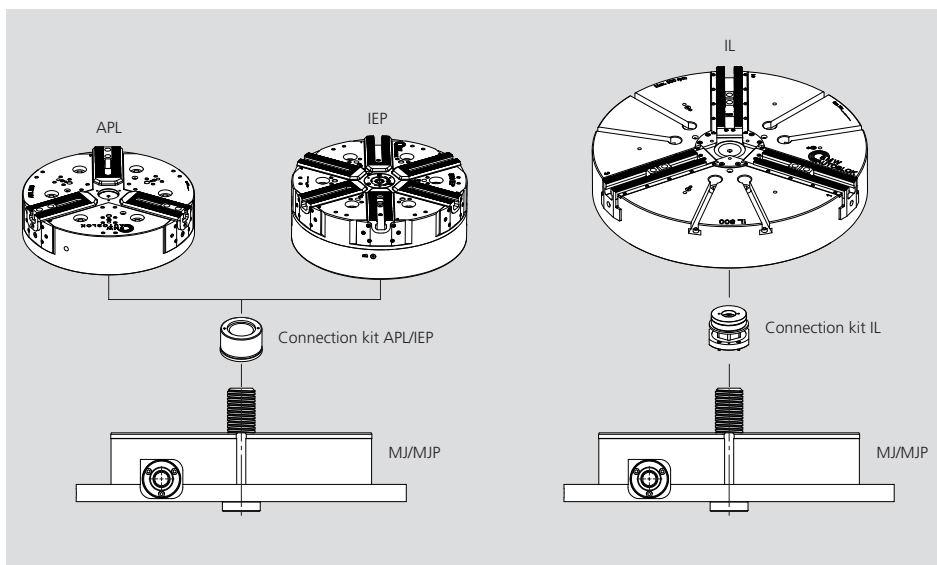
**MJ KIT**

Actuation MJ KIT
to mount APL-C or APL-C chucks

Type	Model chuck	Id.No.
MJ 300	400 APL-D/-C	on request
MJ 380	500-630 APL-D/-C	on request
MJ 520	800-1000 APL-D/-C	on request

Actuation MJ KIT
to mount IL-D or IL-C chucks

Type	Model chuck	Id.No.
MJ 380	500 IL-D IL-C	on request
MJ 380	630 IL-D IL-C	75516310
MJ 380	800 IL-D IL-C	75516310

Technical Data

Type SMW-AUTOBLOK		MJ 300/390	MJ 380/480	MJ 520/750
Id.n.		97503004	97503802	97505201
Chuck Plain Back		300	380	520
Base flange ext. Ø		390	480	750
Max operating torque	Nm	15	15	30
Max draw pull/push	kN	120	120	200
Best for chuck size	mm	315-450	500-630	800-1250
Cylinder unit mass	kg	45	55	85

Manual Jack to operate a power chuck with Ø300-520 Plain Back

MJ

■ Ø300/390 - Ø520/750

STAND ALONE

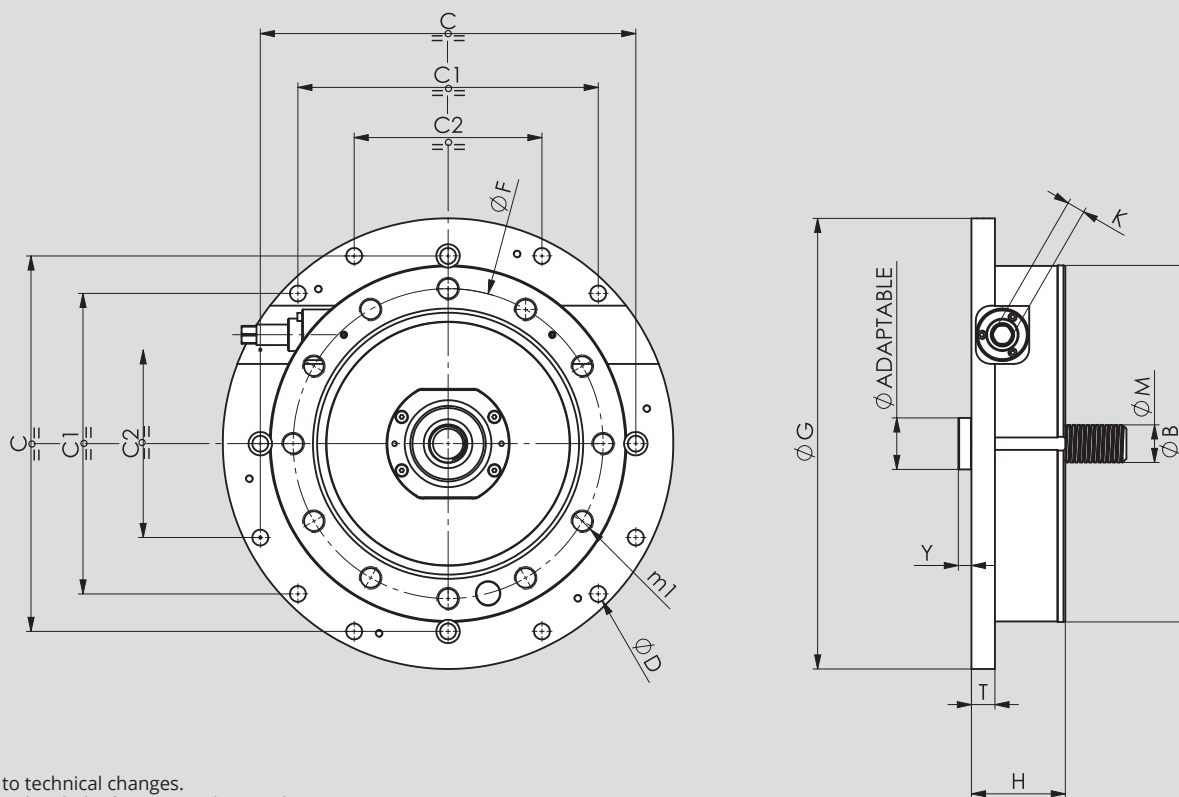

Subject to technical changes.
For more detailed information please ask our customer service.

Type SMW-AUTOBLOK		MJ 300/390	MJ 380/480	MJ 520/750
ØB h7	mm	300	380	520
ØB1 p6	mm	55	55	55
C	mm	-	400	640
C1	mm	320	320	320
C2	mm	160	200	-
ØF	mm	235	330,2	463,6
ØG	mm	390	480	750
H	mm	100	100	100
M TR	mm	40x5	40x5	40x5
m1	mm	M20	M24	M24
T	mm	-	25	25
K	mm	19	19	19
Y	mm	14	14	14
ØDmax	mm	17	17	17



**AUTOBLOK s.p.a.
HEADQUARTERS**

Via Duca D'Aosta n.24 - I-10040 Caprie - Torino
Tel. +39 011 - 9638411 Fax +39 011 - 9632288
E-mail: info@smwautoblok.it

**PETACCIATO DISTRIBUTED PRODUCTION UNIT
CUSTOMER APPLICATIONS FOR STATIC CLAMPING**

Z.I. P.zza Alessandro Volta, snc - I- 86038 Petacciato (CB)
Tel. +39 0875 670001



SMW-AUTOBLOK Spannsysteme GmbH

Postfach 1151 • D-88070 Meckenbeuren
Wiesentalstraße 28 • D-88074 Meckenbeuren
Tel. +49 (0) 7542 - 405 - 0
Vertrieb Inland: Fax +49 (0) 7542 - 3886
E-mail: vertrieb@smw-autoblok.de
Sales International: Fax: +49 (0) 7542 - 405 - 181
E-mail: sales@smw-autoblok.de



Canada



Poland



China



Czech Republic /
Slovakia



France



Sweden / Norway



Japan



Spain



Great Britain



Taiwan



India



Turkey



Korea



U.S.A.



Mexico

www.smwautoblok.com