

0

Soft top jaws

Steel | Aluminium

Inch serration

1/16" x 90° or 3/32" x 90°

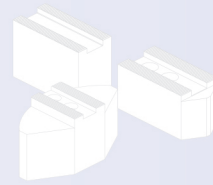

Page 7

1

Hard top jaws

Inch serration

1/16" x 90° or 3/32" x 90°

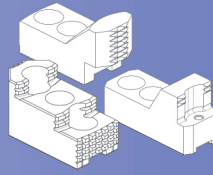

Page 27

2

Soft top jaws

Steel | Aluminium

Metric serration

1.5 x 60° or 3 x 60°

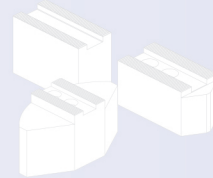

Page 37

3

Hard top jaws

Metric serration

1.5 x 60° or 3 x 60°

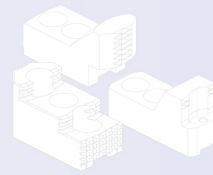

Page 53

4

**T-Nuts
Grippers**

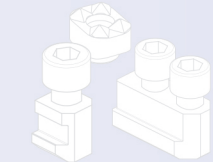

Page 63

5

Soft top jaws

Tongue & groove

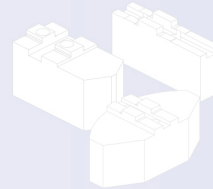

Page 81

6

Hard top jaws

Tongue & groove

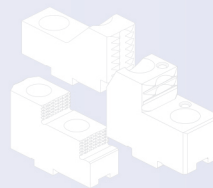

Page 95

7

Quick jaw change

For manual and power chucks
straight modular serration System SMW

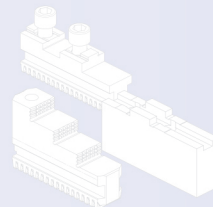

Page 109

8

Quick jaw change

For manual and power chucks
helix modular serration System Forkardt

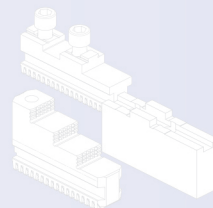

Page 149

9

Special jaws | Boring rings
Cleaning plate | Gripping force tester
Repair service | Calculations



Page 183

MHB-D

Hard, reversible stepped top jaws

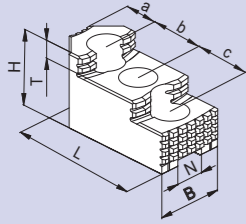

- Inch serration 1/16" x 90° or 3/32" x 90°
- Serration ground



For highest accuracy we recommend to grind the jaws on the chuck under clamping conditions.

Type	Id. No.	B	H	L	T	N	Serration	a + b + c for ISO 4762	kg/ Set	SMW-AUTOBLOK
MHB-D 110	007076	20	31	48.2	7	8	1/16" x 90°	14.5 + 12 + 12 M6	0.35	HFKN-D 110
MHB-D 130	12081306	29.7	34	58.1	8.5	12	1/16" x 90°	13 + 16 + 16 M8	0.60	AN/AL-D 125 BH/HB/PB-D 130 BB-D 140 SP/STP 125
MHB-D 160	12081636	34	39	65.2	10	14	1/16" x 90°	18 + 16.5 + 16.5 M10	0.89	HFKN-D 165 SP/STP 160 AN/AL/BH/HB-D 165 BHD-FC 165 PB/PBI/RC-D 165 AP/NT-D 170 BB-D 175 HYND-S 180
MHB-D 200	12082036	40	45	82.7	10.5	17	1/16" x 90°	19 + 23 + 23 M12	1.68	HFKN-D 210 SP/STP 200/240 AN/AL/BH/BB-D 210 BHD-FC 210 CC 240Z HB/PB/PBI/RC-D 210 AP/APL/NT-D 215 AP/APL/NT-D 260* HYND-S 210/226
MHB-D 260	12082626	45	56	101.1	13.5	17	1/16" x 90°	23 + 30 + 30 M12	3.08	AP/APL/NT-D 260
MHB-D 251	12083036	45	56	106.2	13.5	21	1/16" x 90°	26 + 30 + 30 M16	2.87	HFKN-D 260/315 SP/STP 280
MHB-D 315	12083186	45	56	123.6	13.5	21	1/16" x 90°	43 + 30 + 30 M16	3.72	SP/SP-L 350 AN/AL/BH/BB-D 250 AN/AL/BH/BB-D 315 BHD-FC 250/315 RC-D 250/305/400 CC 350Z HB/PB/PBI-D 250/315 AP/APL/NT-D 315 HYND-S 250/315/400 RC-D 400
MHB-D 401	12084506	60	75	141.1	19	21	1/16" x 90°	38 + 38 + 38 M16	5.10	
MHB-D 500	12084546	60	75	140.8	19	25.5	3/32" x 90°	38 + 38 + 38 M20	7.10	HFKN-D 400/500 AP/AP-L/NT-D 400* BB-N 400/470/500/600 BB-N ES 400/470/500/600 BB-EXL(SC)2G 510/660 AN/AL/BB-D 400 BH-D 400/450/500/630/800 BHD-FC 400/500/630 IN/L-D 500/630/800 HYDL-S 500/630/800 BH-D 630/800 IN/L-D 630/800 HYDL-S 500/630/800
MHB-D 610 ¹	12086346	74	74	146.8	32	25.5	3/32" x 90°	46 + 38 + 38 M20	9.61	

Autoblok	Forkardt	Röhm	Schunk
ODN 125 GHDN 125	KTH 130/140	KFD 130 KFH 140 KFD-HS 160/175 KFD-HE 170 LVE 125/160	HSG 160 ROTA NCD 165
GHD-FC 165 GHDN 165			
ODL 200 ODN 200/220/250 S HDL 200 HDN 200/220/250 S GHD/FC 210 GHDN 210 HDB 220 CD 200 210 RCD	QLK/QLC 160/175/200 QLK/QLC-KS 200/250 QLC/QLC-LS 160/200 HDN 200/220/250 S NH/NHF 160/175/200 KL/KT/KTG/KTN/KS-PS 160/200 KS 160/200/250 KSF 175/200 KGH/KGHF/KTH 160/175/200 KG/KP 200 LVE 160/200/250	KFD/KFD-HF 160/200 KFH/KFH-F/KFH-G/KFH-NC 160/200 KFD-AF 160/200 KFD-HE 210 SPD/SPO 160/215 LVE 200	TH/THF/HSL 165/210 ROTA NCD 185/210 ROTA NC/ROTA NCF 165/210 KFD-HE 210 ROTA NCK plus 210/250 ROTA 2B 160 ROTA TP 200 TP 200
ODL 250/315/400 ODN 250/315/400 HDL 250/315/400 HDN 200/315/400 GHD/FC 250/305/400 GHDN 250/315/400 HDB 300 CD 250/315-65/315-85 250 RCD 305 RCD	QLK/QLC 250/315 QLK/QLC-KS 315/400 QLK/QLC-LS 250/315 QLC-AG 250/315 KG/KT/KP/KTG/KTN/KTGF 250/315 KLNC/NH/NHF 250/315 KS 315/400 KSPS 250/300 KSH/KSHF 250/315/400 HF315 LVE315	KFD/KFD-HF 250/315 KFH/KFH-F/KFH-G/KFH-NC 250/315 KFD-AF 250/315 KFD-HE 254/315 KFL 315/400 SPD/SPO 300 LVE 250/305/315	TH/THF/HSL 250/315 ROTA NC/ROTA NCD 250/315 ROTA NCF 250/315 KFD-HE 254/315 ROTA NCO 260/315 ROTA NCK plus 315 ROTA TP 250/315 TP 250/315
	QLK/QLC 400 NH/NHF 400/500/630 KT/KTGF 400/500/630 KS 500/630 KG/KL/KP/KLNC 400/500 KSHF 630 KSH 500 KSL 630 KSPS 400 LVE 400/500/630/800 NH/NHF 630 KT/KTGF 630 KS 630 KSHF 630 KSL 630 LVE 630/800	KFD 400/500/630/800 KFD-HF 400/500/630 KFD-HS 400/500 KFD-HE 400 KFH/KFH-F/KFH-G/KFH-NC 400/500 KFL 500/600 KFD-HE 400 LVE 400/500/630/800/1000	TH/THF 400/500 HSL 400 HSG 400/500 ROTA NC/ROTA NCD 400/500 ROTA NCF/ROTA NCO 400/500
	KFD 630/800 LVE 630/800/1000		

¹ 1 step only
* With single T-nuts only

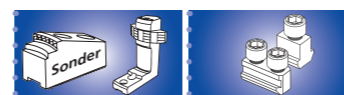

SMW-AUTOBLOK
35, 184, 186

SMW-AUTOBLOK
63

MHB-D

Hard, reversible stepped top jaws for front end power chucks

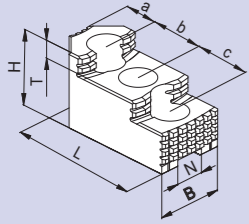

- Inch serration 1/16" x 90° or 3/32" x 90°
- Serration ground

Type	Id. No.	B	H	L	T	N	Serration	a + b + c f. ISO 4762	kg/ Set	SMW-AUTOBLOK	Röhms	Schunk
MHB-D 125	013817	24	40	57.7	9	11	1/16" x 90°	9.5 + 18 + 18 M8	0.68		LV 125	TP 125-26 ROTA TP 125
MHB-D 130	12081306	29.7	34	58.1	8.5	12	1/16" x 90°	13 + 16 + 16 M10	0.60	SP 125-26 ab Bj. 98 STP 125 ab Bj. 98		
MHB-D 160	12081636	34	39	65.2	10	14	1/16" x 90°	18 + 16.5 + 16.5 M10	0.89	SP 160-38 STP 160	LVE 160	TP 160-38 ROTA TP 160
MHB-D 200	12082036	40	45	82.7	10.5	17	1/16" x 90°	19 + 23 + 23 M12	1.68	SP 200/240 STP 200/240	LVE 200	TP 200-52 ROTA TP 200
MHB-D 251	12083036	45	56	106.2	13.5	21	1/16" x 90°	26 + 30 + 30 M16	2.87	SP 250/280/350 STP 280	LVE 305 LVE 250	TP 250/315 ROTA TP 250/315 ROTA TP 350
MHB-D 315	12083186	50	56	123.6	13.5	21	1/16" x 90°	43 + 30 + 30 M16	3.72	SP 350 SP-L 350	LVE 315	TP 315 ROTA TP 315/350
MHB-D 500	12084546	60	75	140.8	19	25.5	3/32" x 90°	38 + 38 + 38 M20	7.10	BB-N 400/470 BB-N 500/600 BB-N ES 400/470 BB-N ES 500/600 BB-EXL(SC)2G 510 BB-EXL(SC)2G 660	LVE 400/500 LVE 630/800 LVE 1000	TB 400/500 ROTA EP 380/46 ROTA TB 400/500 ROTA TB 610 ROTA TB 630-265 LH
MHB-D 630 ¹	12086446	75	85	161.8	30	30	3/32" x 90°	30 + 50 + 50 M24	13.50	BB-N 630-310 BB-N ES 630 BB-AZ2G 685 BB-AZ2G 740 BB-AZ2G 1000 BB-EXL(SC)2G 900		ROTA TB 630
MHB-D 800 ¹	12088046	75	85	220	30	30	3/32" x 90°	51 + 62 + 62 M24	19.50	BB-N 800-410 BB-N ES 850 BB-N ES 1000 BB-AZ2G 685 BB-AZ2G 740 BB-AZ2G 1000 BB-EXL(SC)2G 900		TB 800/1000/1200 ROTA TB 800/850 ROTA TB 1000/1200

¹ 1 step only

Hard special jaws to customer request

- Simply copy and fax to: +49 (0) 7542 3886
- Download from www.smw-autoblok.de

Hard top jaw for external clamping with smooth clamping surface

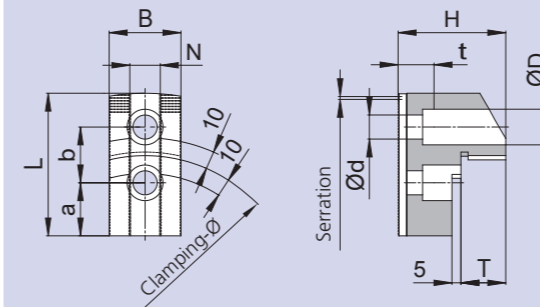

Dimensions			
a	mm	L	mm
b	mm	N	mm
B	mm	t	mm
d	mm	T	mm
D	mm	Clamping-Ø	mm
H	mm	Workpiece-Ø	mm

Jaw serration (please mark)			
	1/16" x 90°		1.5 x 60°
	3/32" x 90°		3 x 60°

Material
Quantity in pieces
Chuck manufacturer
Chuck type + size

Hard top jaw for internal clamping with smooth clamping surface

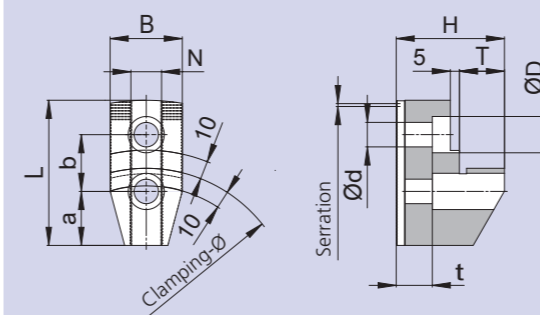

Dimensions			
a	mm	L	mm
b	mm	N	mm
B	mm	t	mm
d	mm	T	mm
D	mm	Clamping-Ø	mm
H	mm	Workpiece-Ø	mm

Jaw serration (please mark)			
	1/16" x 90°		1.5 x 60°
	3/32" x 90°		3 x 60°

Material
Quantity in pieces
Chuck manufacturer
Chuck type + size

Hard top jaw for external clamping with serrated clamping surface

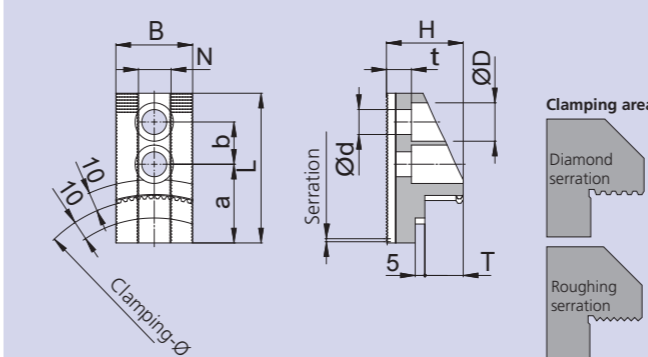

Dimensions			
a	mm	L	mm
b	mm	N	mm
B	mm	t	mm
d	mm	T	mm
D	mm	Clamping-Ø	mm
H	mm	Workpiece-Ø	mm

Jaw serration (please mark)			
	1/16" x 90°		1.5 x 60°
	3/32" x 90°		3 x 60°

Clamping area (please mark)
Diamond serration
Roughing serration
Material
Quantity in pieces
Chuck manufacturer
Chuck type + size

Hard top jaw for internal clamping with serrated clamping surface

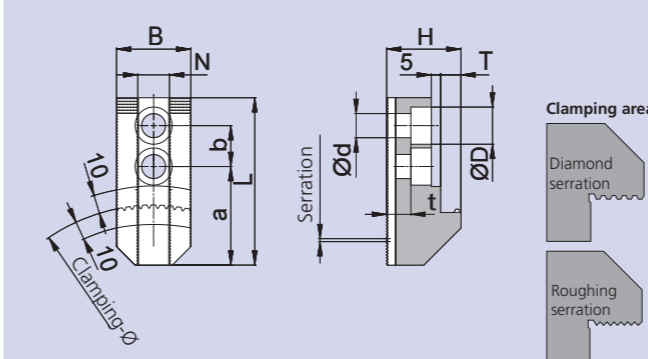

Dimensions			
a	mm	L	mm
b	mm	N	mm
B	mm	t	mm
d	mm	T	mm
D	mm	Clamping-Ø	mm
H	mm	Workpiece-Ø	mm

Jaw serration (please mark)			
	1/16" x 90°		1.5 x 60°
	3/32" x 90°		3 x 60°

Clamping area (please mark)
Diamond serration
Roughing serration
Material
Quantity in pieces
Chuck manufacturer
Chuck type + size

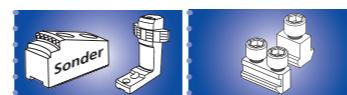

SMW-AUTOBLOK
35, 184, 186

SMW-AUTOBLOK
63