

- Serration 2.5 x 60°
- Quick change system „CLAK-System“ optional available



Application/customer benefits

- Full usability of the machine table
- Modular system: Extensive range of accessories
- Quick change system „CLAK-System“ for jaws and parallel claks optional available (see page 223)
- Maximum efficiency due to quick change over
- Can be used for single or multiclamp

Technical features

- Serration: 2.5 x 60°
- Jaw width: 38 mm, 60 mm und 90 mm, Length: 250 mm, 400 mm, 500 mm and 630 mm
- Optional: Interfaces for zero point clamping system APS / WPS / ZeroAct (on request)



Standard equipment

Multiple clamping system:
 Base, fix jaw (one side with SinterGrip; one side smooth), CV-S 60: 2pcs. STD SinterGrip inserts / CV-S 90: 3pcs. STD SinterGrip inserts (SinterGrip inserts ALU or HRC on request), 1 pair of 12mm positioning keys, clamping wrench, workstop

Technical data

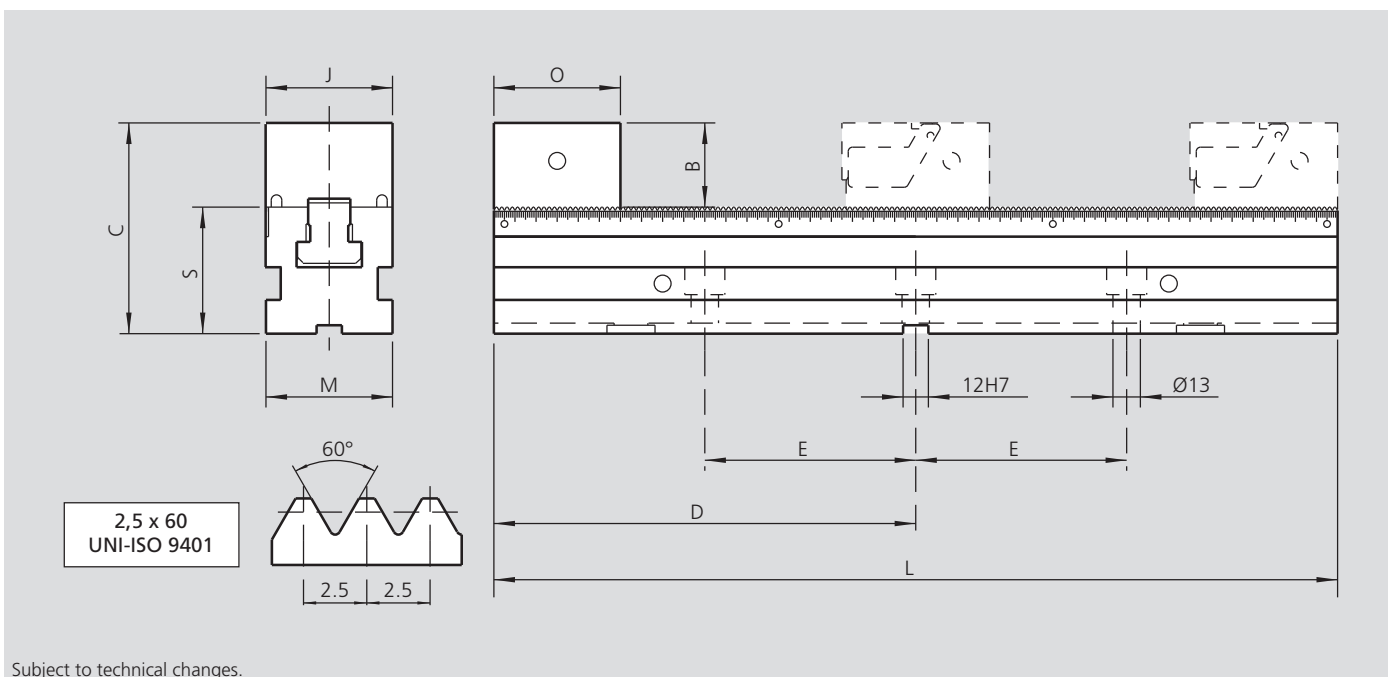

Type	Id. No.	B [mm]	C [mm]	D [mm]	E [mm]	J [mm]	L [mm]	M [mm]	O [mm]	S ±0.01 [mm]	Weight [kg]
CV-S 60-250	77584664	40	100	125	100	60	250	60	60	60	6.5
CV-S 60-400	77584661			200	100		400				9.5
CV-S 60-500	77584662			250	150		500				11.5
CV-S 60-630	77584663			315	200		630				13.5
CV-S 90-250	77584694	45	115	125	100	90	250	90	70	70	11
CV-S 90-400	77584691			200	100		400				16
CV-S 90-500	77584692			250	150		500				19.5
CV-S 90-630	77584693			315	200		630				23.5

- Serration 2.5 x 60°
- Quick change system „CLAK-System“ optional available

Clamping force diagrams

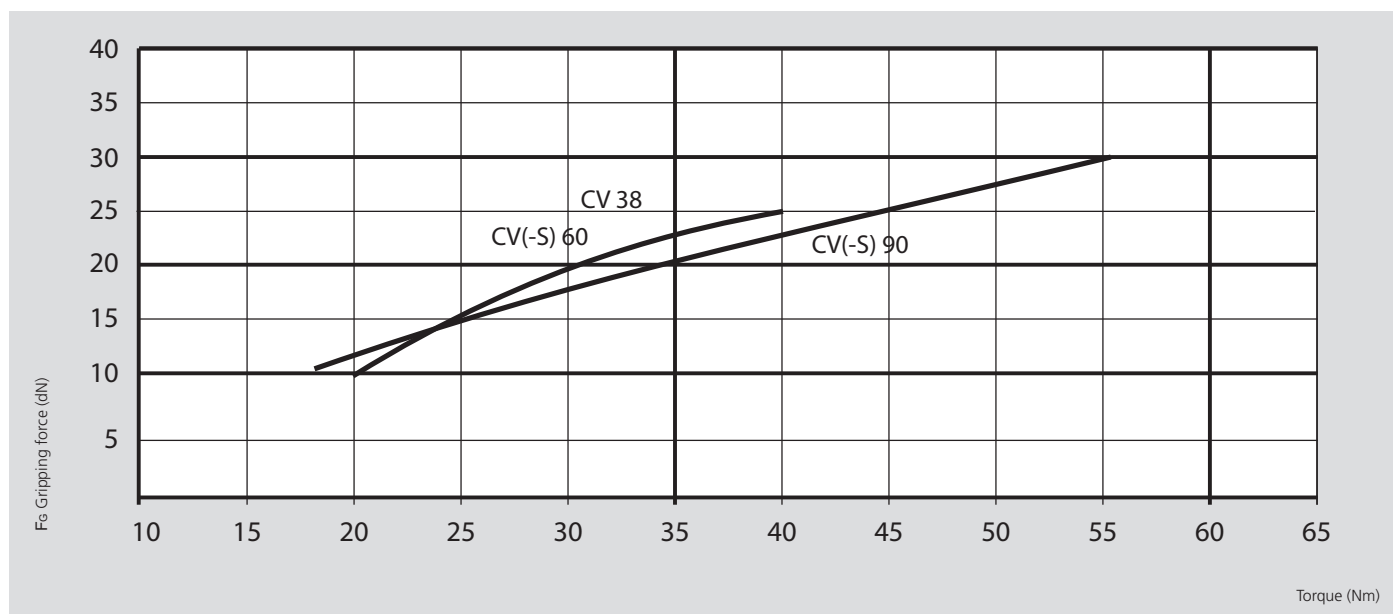

Clamping capacity

Type	A max. [mm]			
	Diagram 1	Diagram 2	Diagram 3	Diagram 4
CV 38-250	120	25	-	-
CV 38-400	270	100	43	15
CV 38-500	370	150	76	40
CV 38-630	500	215	120	73
CV(-S) 60-250	120	25	-	-
CV(-S) 60-400	270	100	43	15
CV(-S) 60-500	370	150	76	40
CV(-S) 60-630	500	215	120	73
CV(-S) 90-250	99	-	-	-
CV(-S) 90-400	249	84	29	-
CV(-S) 90-500	349	134	62	26
CV(-S) 90-630	479	199	106	59

Application examples CV-S

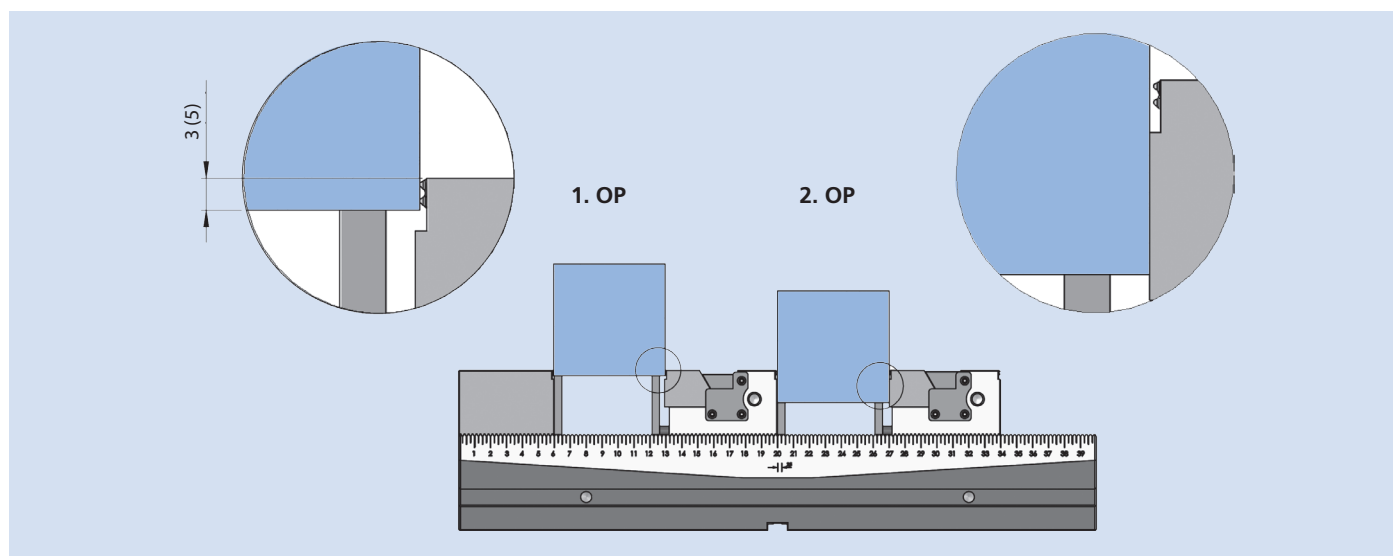

Movable jaw set CV-S 60

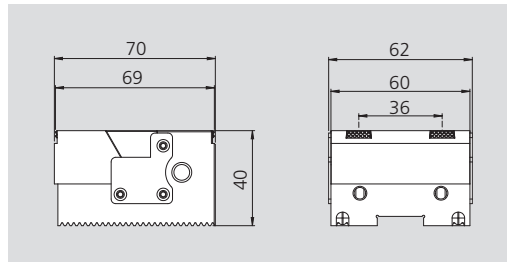

Consisting of:

Movable jaw set complete with 1 work stop, 4 SinterGrip inserts STD for steel*, 1 pair of parallels H37

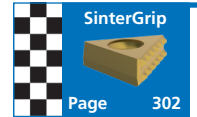

Type	Id. No.	Weight [kg]
CV-S 60	77584660	1.4

Movable jaw set CV-S 90

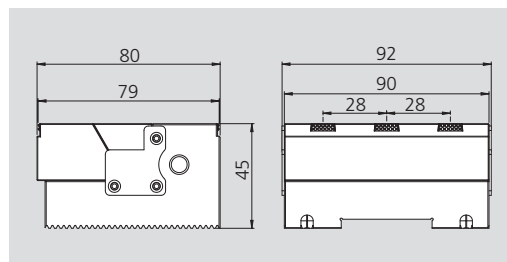
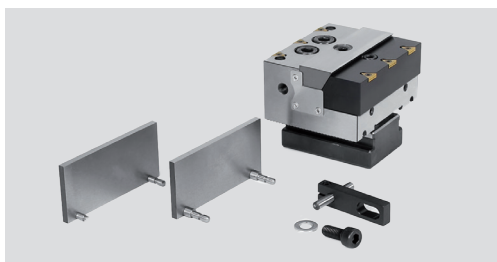

Consisting of:

Movable jaw set complete with 1 work stop, 6 SinterGrip inserts STD for steel*, 1 pair of parallels H42

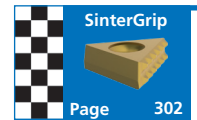

Type	Id. No.	Weight [kg]
CV-S 90	77584690	2.9

Fixed jaw set CV-S 60

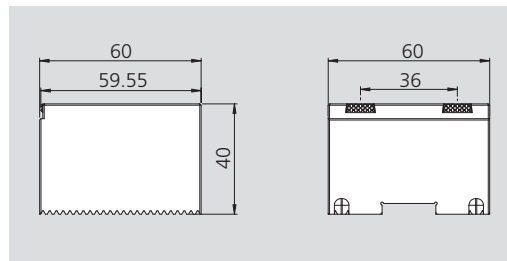

Consisting of:

Fixed jaw set complete with 1 work stop, 2 SinterGrip inserts STD for steel*



Type	Id. No.	Weight [kg]
CV-S 60	58467260	1.4

Fixed jaw set CV-S 90

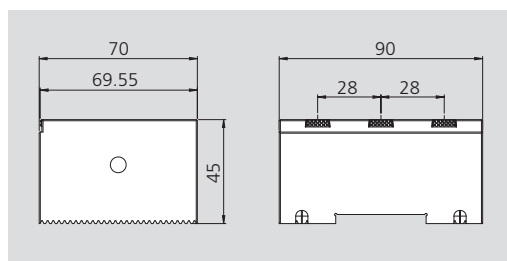

Consisting of:

Fixed jaw set J60 complete with 1 work stop, 3 SinterGrip inserts STD for steel*

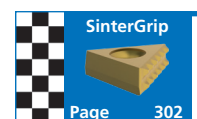

Type	Id. No.	Weight [kg]
CV-S 90	58467290	2.9

* ALU or HRC on request.