

FRS

Self centering clamping
TONGUE & GROOVE

Lever chuck Ø 215 - 365 mm

- Self centering clamping
- Large through-hole
- proofline® chucks = fully sealed - low maintenance

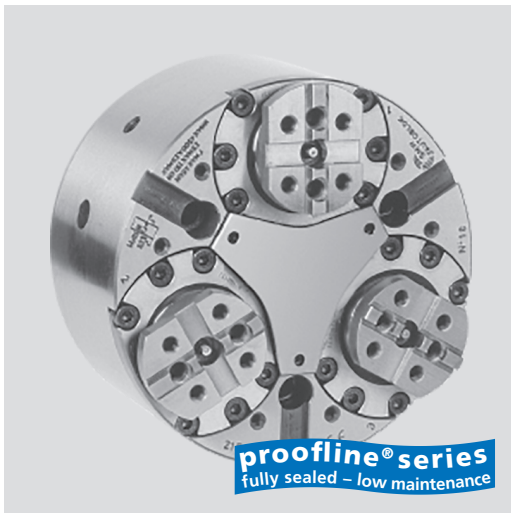

Application/customer benefits

- Self centering clamping of flange or shaft type workpieces where the reference is not a center but the O.D. of the workpiece
- The through-hole of the chuck allows to swallow the workpiece if needed
- Due to its high rigidity against torsion the chuck can be used for turning as well as for milling

Technical features

- For O.D. clamping only
- Large through-hole
- Tongue & groove base jaws
- Pull-down to axial datum

- Permanent grease lubrication
- Rigid design against torsion
- **proofline® chucks** = fully sealed - low maintenance

Standard equipment

3-jaw chuck
Mounting bolts

Ordering example

3-jaw chuck FRS 285 Z 220

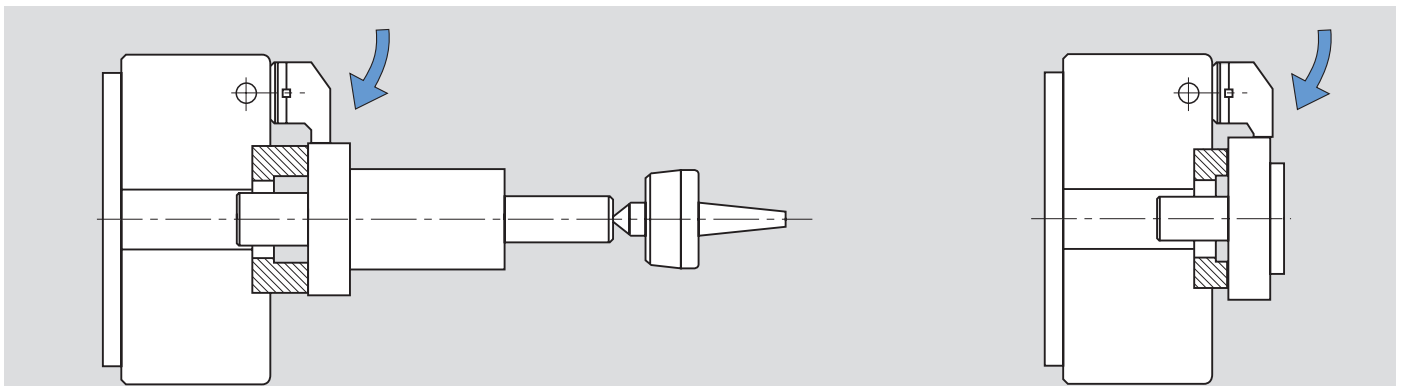

■ FRS self centering chuck with pull-down

The pull-down of the chuck pulls the workpiece against the workstop.
The large bore allows the workpiece to be swallowed.

Technical data

SMW-AUTOBLOK Type		FRS 215	FRS 285	FRS 365
Angular jaw stroke	deg.	6°	6°	6°
Radial jaw stroke at distance h	mm	6.3	7.3	8.4
Wedge stroke	mm	22	26	31
Max. draw pull	kN	45	70	110
Max. gripping force at distance h	kN	100	150	240
Max. speed*	r.p.m.	4500	3500	2500
Weight (plain back without top jaws)	kg	30	62	120
Moment of inertia	kg·m ²	0.17	0.65	2
Recommended actuating cylinders	Type	SIN-S 100 - 125	SIN-S 125 - 150	SIN-S 150 - 200
Id. No. FRS		77818521	77818528	77818536

* The above maximum speed is allowed with standard weight / height top jaws and applying the full draw pull only. For more information please contact SMW-AUTOBLOK.



SMW-AUTOBLOK
472

SMW-AUTOBLOK
466

SMW-AUTOBLOK
327

Lever chuck Ø 215 - 365 mm

FRS

- Self centering clamping
- Large through-hole
- proofline® chucks = fully sealed - low maintenance

Self centering clamping
TONGUE & GROOVE

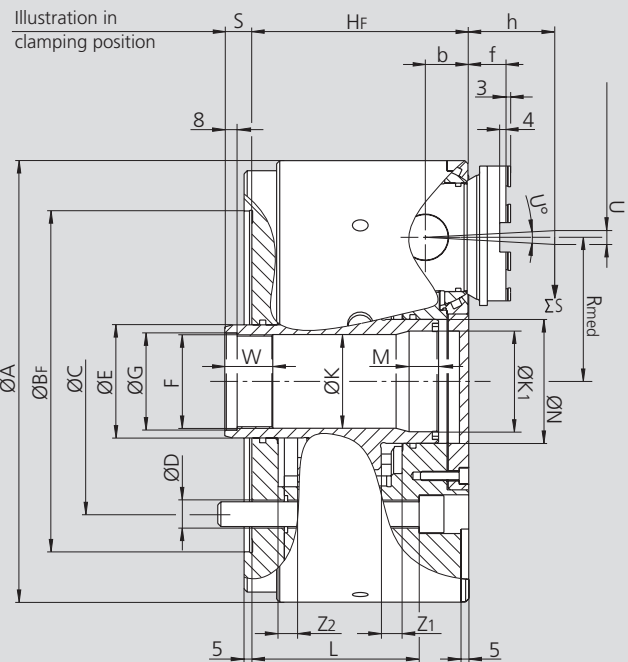
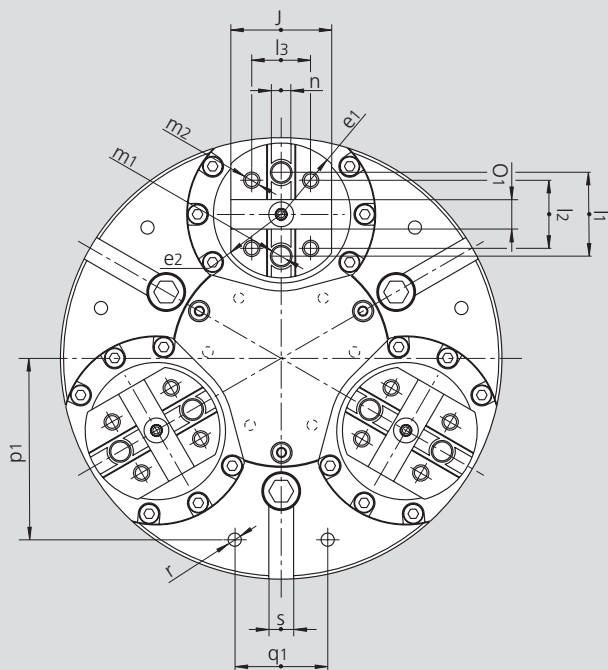

Subject to technical changes.
For more detailed information please ask our customer service.

4

SMW-AUTOBLOK Type		FRS 215	FRS 285	FRS 365	
	A	mm	215	285	365
	Bf H6	mm	170	220	300
	C	mm	133.4	171.4	235
	D	mm	M12	M16	M20
	E	mm	50	73	79
	F	mm	M42 x 1.5	M60 x 1.5	M68 x 2
	G H8	mm	43	61	69
Through-hole	HF	mm	120	140	168
	K	mm	40	60.5	60.5
	K1	mm	-	65	75
	L	mm	95	108	123
	M	mm	-	19	23.8
	N	mm	52	80	90
	Rmed	mm	67	93	120
Middle stroke = clamping position	S	mm	15.4	17.5	24.8
Min. / max.	S	mm	4 / 26	4 / 30	9 / 40
Angular jaw movement	U °	deg.	6°	6°	6°
Radial stroke at distance h ⁽¹⁾	U	mm	6.3	7.3	8.4
	W	mm	30	31	30
	Z1	mm	11.4	13.5	15.8
	Z2	mm	10.6	12.5	15.2
	b	mm	22	28	34
	e1	mm	37.5	46	50
	e2	mm	33	41	50
Reference height	f	mm	18	24	21
	h	mm	38	42	46
	j	mm	55	65	70
	l1	mm	38	54	63.5
	l2	mm	32	44	48
	l3	mm	32	38	48
Thread / depth	m1	mm	M12 / 16	M16 / 20	M16 / 20
Thread / depth	m2	mm	M10 / 14	M12 / 19	M12 / 19
	n h8	mm	7.94	12.7	12.7
	o1 H7	mm	12.68	19.03	19.03
	p1	mm	80	117	150
	q1	mm	45	60	80
Thread / depth	r	mm	M8 / 17	M10 / 19	M12 / 22
	s H8	mm	16	16	20

⁽¹⁾ Calculated at **h** distance from the chuck's face (where normally the clamping takes place).