

SMW-AUTOBLOK

worldwide leader

in Steady Rests

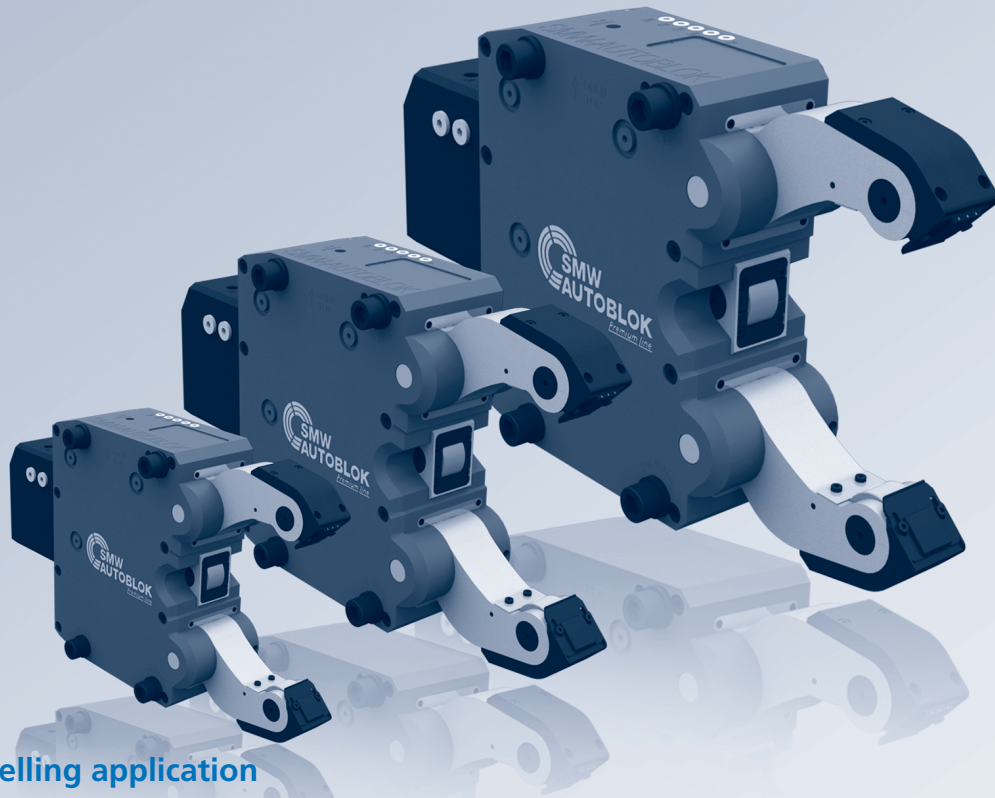

Fixed or travelling application

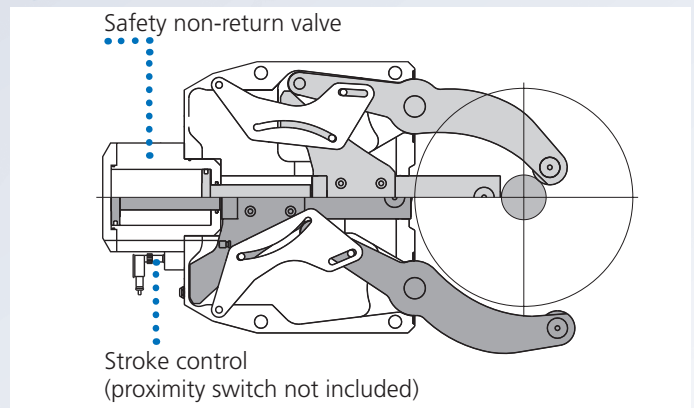
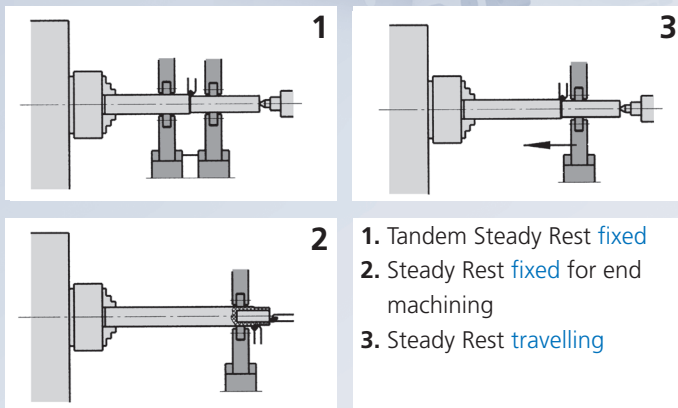

Features included in standard range

Steady Rest Type	Standard Line		Basic Line	Premium Line					
	SLU-X	SLUB, SLUB-A		SR	SRA	SR-CL	K, KA	KLU, KLU-A	RX
Steady Rest Size	1 - 5.1	3 - 6	1 - 6	2 - 6	2 - 6	4 - 6	3 - 7.1	215 - 540	2 - 6.1
Sealed body	■	■	■	■	■	■	■	■	■
Safety valve	■	■	■	■	■	■	■	■	■
Stroke control (proximity switch not included)	■	■	■	■	■	■	■	■	■
1 set swarf guard 3-piece	■	■	■						
1 set swarf guard with integrated coolant flush				■	■	■	■	■	■
1 set cylindrical rollers	■	■	■	■	■	■	■	■	■
Port for compressed air	■	■	■	■	■	■	■	■	■
Port for coolant through arms incl. chipguard				■	■	■	■	■	■
Toolbox	■	■		■	■	■	■	■	■

SLU-X® · SR® · K · KLU · RX

**SLU-X / SLU / SR /
K / KLU / RX**
large clamping
range

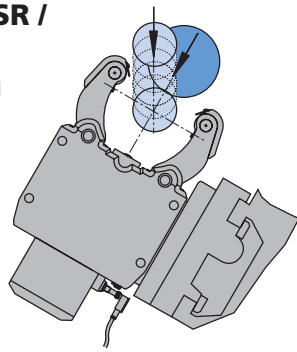

SLU-A / SRA / KLU-A / KA
additional pivoting
upper arm
for automatic vertical
loading

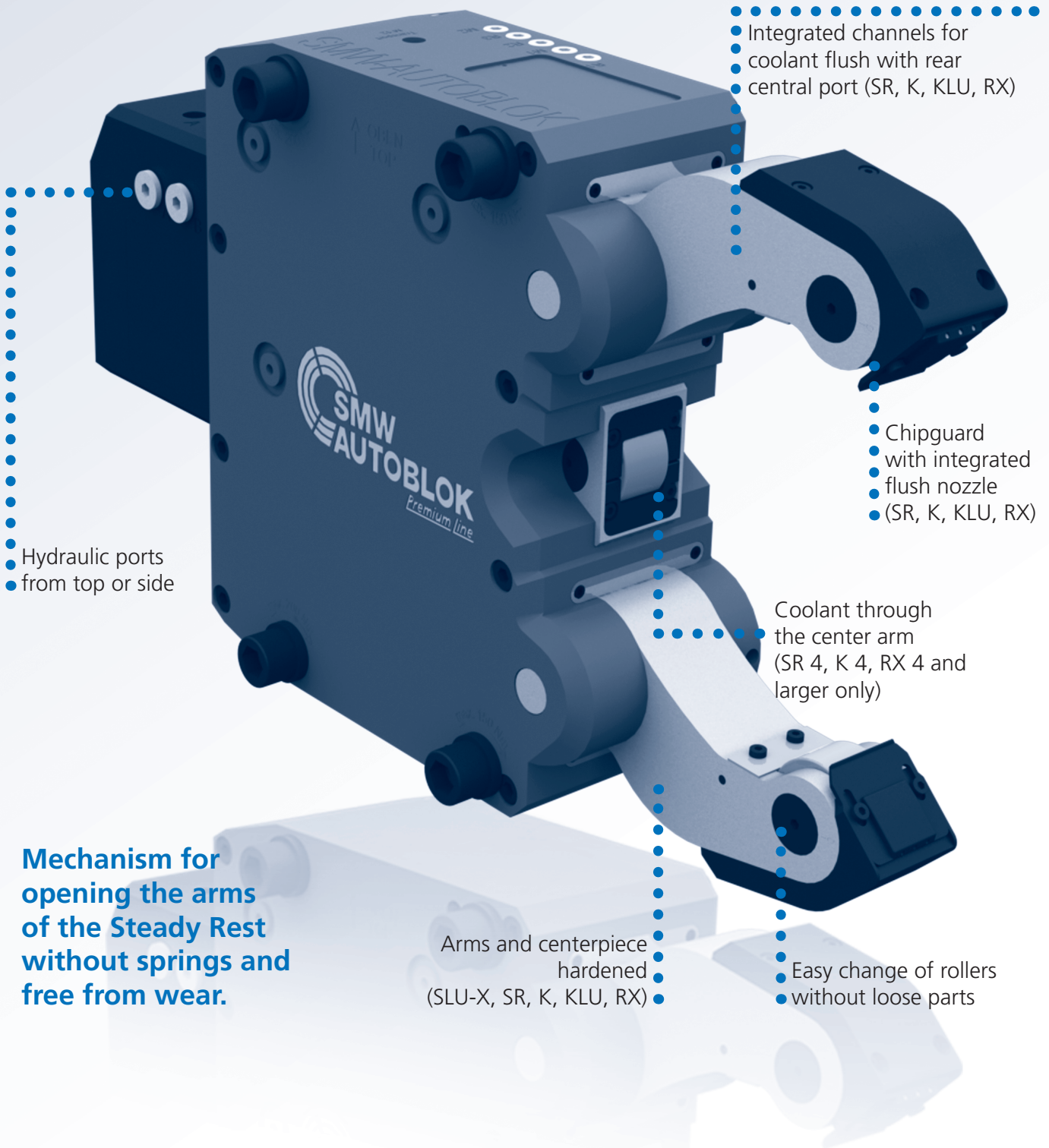
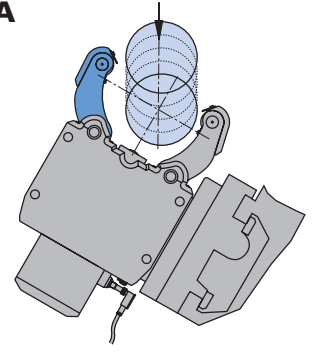

- Integrated channels for coolant flush with rear central port (SR, K, KLU, RX)

- Hydraulic ports from top or side

- Chipguard with integrated flush nozzle (SR, K, KLU, RX)

- Coolant through the center arm (SR 4, K 4, RX 4 and larger only)

Mechanism for opening the arms of the Steady Rest without springs and free from wear.

- Arms and centerpiece hardened (SLU-X, SR, K, KLU, RX)

- Easy change of rollers without loose parts

SLU-X[®]
SLUB / -A

SLU
SLU-A

SR[®] / -CL
SRA

KLU / -A
K / KA

RX

Option of manual lubrication (M) (all types)

- Low cost solution for medium working conditions and low build up of swarf.
- The lubrication points and rollers are supplied with lubrication grease via the grease nipples and the grease gun.
- Lubrication intervals depending on the working conditions normally every 4 to 8 operating hours.
- Grease: KPE 2R-20 DIN 51502.

Manual lubrication (M)

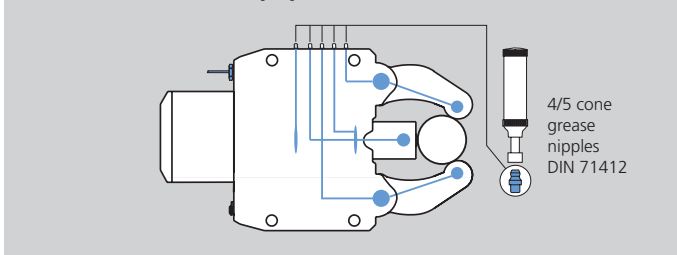

Option of central oil lubrication (Z) (all types)

- For heavy working conditions and high build up of swarf.
- For travelling Steady Rest applications.
- The use of our separate complete lubrication unit with timer control is recommended.
- Lubricating intervals 5 - 20 min.
- Min. / max. operating pressure 10 / 45 bar.
- Oil: Viscosity of 46 mm² / s (viscosity class ISO).

Central lubrication oil (Z)

Centralized lubrication G 1/8"

Lubrication unit oil

Id. No. 088707

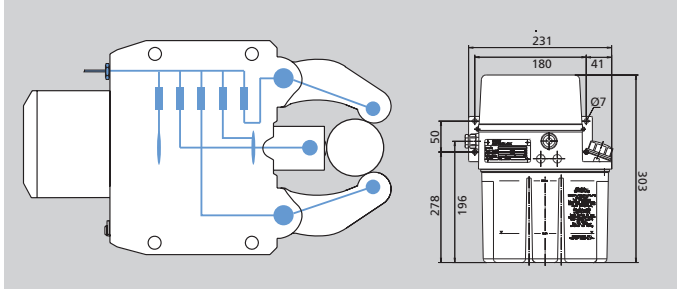

Option of central lubrication oil + air (OLD) (all types)

- For heaviest cutting conditions with high built up of swarf, dust or coolant.
- The SMW-AUTOBLOK oil + air unit for lubrication with built-in timer control is mandatory.
- This unit injects oil for lubrication into the air hose in adjustable intervals (1 - 4 min.).
- The permanent air flow (min. 3 bar) feeds the oil to the rollers and keeps them clean.
- Oil: Viscosity of 46 mm² / s (viscosity class ISO).

Oil + air lubrication (OLD)

Centralized lubrication G 1/8"

Lubrication unit oil + air

Id. No. 088708

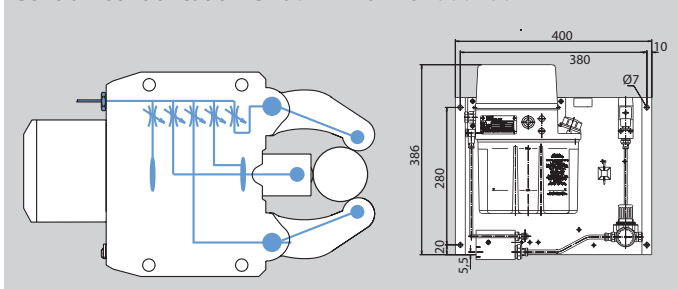

Option of central grease lubrication (F) (not SLU / SLU-A / SLUB / SLUB-A)

- For machines with central grease lubrication.
- For application and intervals please follow the instruction of the machine maker.
- Min. / max. operating pressure 30 / 45 bar.
- Grease: NLGI class 0 or 1.

Central grease lubrication (F)

Centralized lubrication G 1/8"

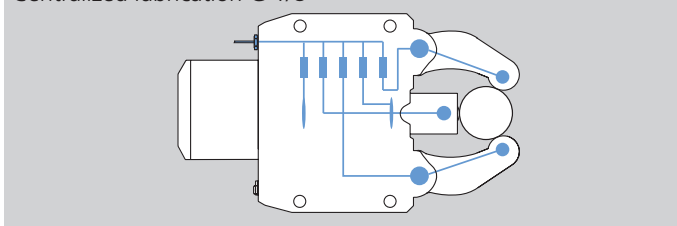

Option of rollers (all types)

- SMW-AUTOBLOK rollers (precision class P05) specially developed for our Steady Rests.
- Special sealing ensures highest precision and service life.
- Standard equipment: 1 set of cylindrical rollers.
- Option: Spherical rollers (for travelling Steady Rests), synthetic material rollers, carbide rollers.

Original SMW-AUTOBLOK roller



cylindrical

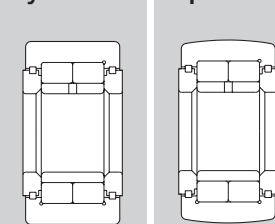

spherical

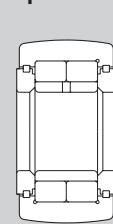

narrow

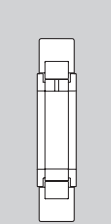

Rollers (all types)

- Rollers steel (standard): Surface of workpiece not hardened.

Available optional materials:

- Rollers synthetic material: Surface of workpiece polished or chrome plated.
- Rollers carbide: Surface of workpiece hardened.

Rollers steel

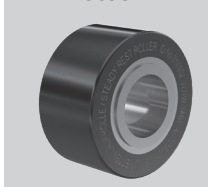

Rollers synthetic material



Rollers carbide

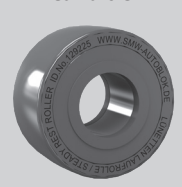

SLU-X[®]
SLUB / -A

SLU
SLU-A

SR[®] / -CL
SRA

KLU / -A
K / KA

RX

Eccentric fine adjustment

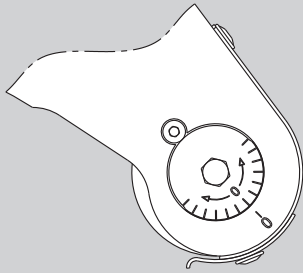

Option fine adjustment of center line (all types)

- Eccentric roller pins on the two Steady Rest arms allow a quick fine adjustment of the center line.
- Therefore no need to unlock and adjust the entire Steady Rest on the bracket for small adjusting movements.
- Adjustment of open Steady Rest only!

Coolant / air feed

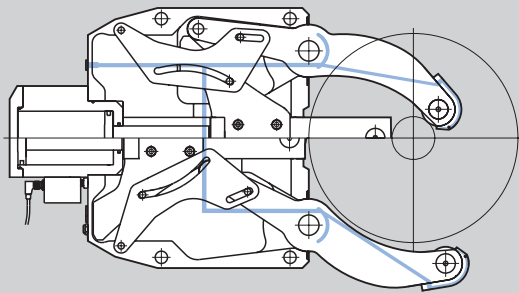

Coolant / air feed (SR / K / KLU / RX only)

- Built-in channels to feed coolant or air from a central connecting port to the Steady Rest arms.
- Basic equipment for SR / K / KLU / RX Steady Rests.
- From size SR-4 / K4 and larger with coolant through the center arm.

Chipguard coolant / air

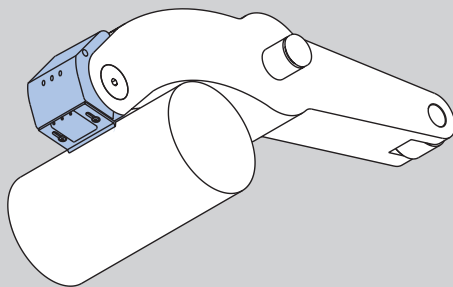

Patented coolant / air chipguard with integrated flush nozzles (SR / K / KLU / RX only)

- Keeps roller clamping area free from chips.
- The patented double flush nozzles keep front and rear of the wiper area clean.

Only for Steady Rests with coolant / air feed

Benefit:

- Constant centering accuracy.
- No damage of workpiece and rollers caused by chips / swarf.
- Less roller consumption = less costs.

SCU diameter measuring system

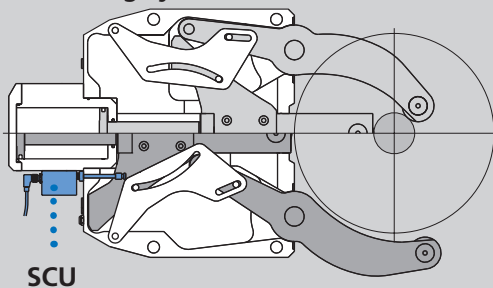

Option linear diameter measuring system SCU (not SLU, SLUB, SLU-A, SLUB-A)

- The position of the clamping arms is monitored by the linear measuring system SCU.
- Avoids collision with workpieces, turret, loader etc.
- Reduced cycle time due to position controlled opening of the arms to the requested opening only.
- Power supply SCU: In: 24 V Out: 4 - 20 mA

Steady Rest bracket with adjustment device

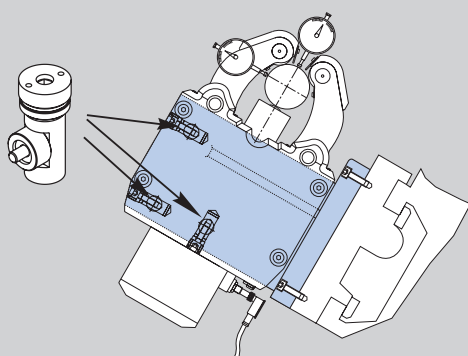

Steady Rest bracket

- A suitable bracket is very important for the function / precision of the Steady Rest.
- Fast and easy adjustment can be done with the SMW-AUTOBLOK **adjustment device** integrated into the bracket.
- SMW-AUTOBLOK supplies the correct bracket for all applications as a turnkey solution.

SRA

Self-centering Steady Rests
Premium line

Additional pivoting upper arm for vertical loading

- Integrated coolant flush
- Chip guard with coolant nozzles
- Stroke control unit or proximity switch for end position open
- proofline® = fully sealed - low maintenance

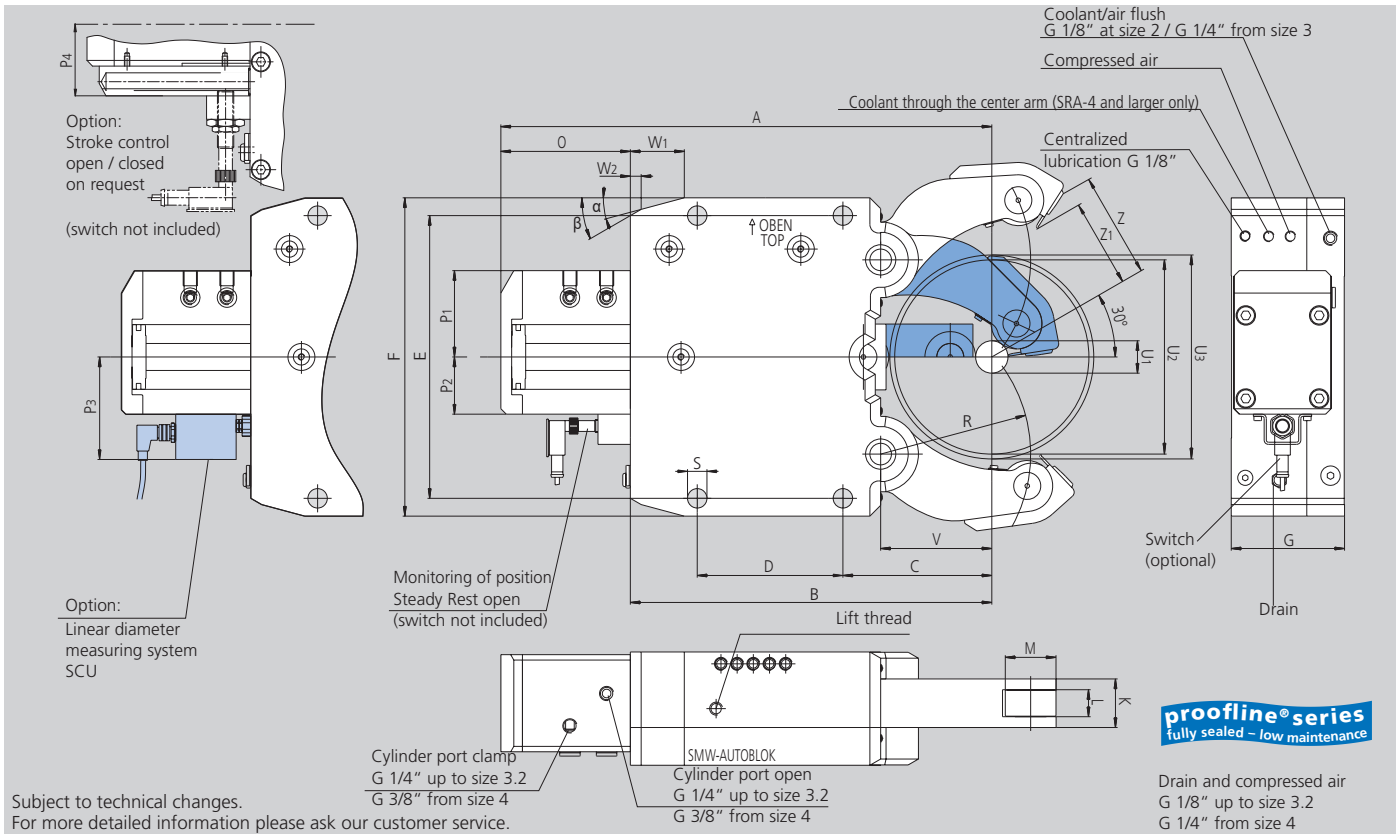

SMW-AUTOBLOK Type Size		SRA 2	SRA 3	SRA 3.1	SRA 4	SRA 5	SRA 6	
Centering range with coolant chip guard	U1	20 (8*)	28 (12*)	25 (22*)	30	45	175	
	U2	80	130	150	220	268	460**	
Max. axial clearing diameter	U3	99	162	168	253	295	466	
Vertical loading with chip guard	Z1	35	58	68	103	121	215**	
Vertical loading without chip guard	Z	41	66	76	111	135	231**	
	A	277	428	436	603	697	953.5	
	B	195	312	320	448	510	715	
	C	70	115	123	146	178	215	
	D	85	135	135	240	270	330	
	E	170	262	262	365	400	680	
	F	195	295	295	405	440	610 / 640	
	G	75	105	105	125	150	175	
	K	35	45	45	60	75	85	
	L	19	25	25	25	29	32	
	Width of rollers	M	35	47	47	52	62	90
	Diameter of rollers	O	82	116	116	155	187	238.5
		P1	63	85	85	91	97	122
		P2	40	53	53	61	63	88
		P3	82	95	95	103	105	130
P4		61	74	74	82	84	109	
R		74	119	124	172	209	290	
S		14	18	18	23	23	27	
V		51	85	93	128	160	190	
W1		30	50	50	58	62	100	
W2		11.2	10	10	18.3	19.1	22	
α		15°	15°	15°	15°	18°	10°	
β		30°	30°	30°	40°	40°	50°	
Piston area***		cm ²	19.6	38.5	38.5	63.6	78.5	176.7
Operating pressure min. / max.		bar	70	80	80	70	80	75
Max. clamping force / roller	daN	450	1000	1000	1500	2000	4500	
Centering accuracy within the whole range	mm	0.02	0.04	0.04	0.05	0.06	0.06	
Repeatability accuracy	mm	0.005	0.007	0.007	0.007	0.01	0.01	
Max. roller surface speed	m/min	800	725	725	715	600	560	
Weight approx.	kg	14	56	57	117	174	436	

* The Steady Rest can be modified to this clamping range (see instruction manual page 24) if the coolant chip guard is not used.

** SRA-6: Loading diameter only under 19° installation.

*** Cylinder sizes different from standard available on request.

- Ordering review
- Accessories
- Wearing parts

SRA Steady Rest with stroke control Steady Rest open via proximity switch (without proximity switch)***

Steady Rest size		2	3	3.1	4	5	6
SRA-M Manual lubrication	Id. No.	128163	128175	128193	127025	128025	128457
SRA-Z Central lubrication oil	Id. No.	128164	128176	128194	127024	128024	128456
SRA-OLD Central lubrication oil + air	Id. No.	128165	128177	128195	127026	128026	128458
SRA-F Central grease lubrication	Id. No.	227453	226444	on request	on request	on request	on request

SRA Steady Rest with stroke control via linear stroke control SCU, output 4 - 20 mA















Steady Rest size		2	3	3.1	4	5	6
SRA-M Manual lubrication	Id. No.	227454	128178	128196	127031	128031	128467
SRA-Z Central lubrication oil	Id. No.	on request	128179	128197	127030	128030	128468
SRA-OLD Central lubrication oil + air	Id. No.	on request	128180	128198	127032	128032	128469
SRA-F Central grease lubrication	Id. No.	227455	on request	on request	on request	on request	on request

SRA Steady Rest with stroke control via linear stroke control SCU, output 0 - 10 V

Steady Rest size		2	3	3.1	4	5	6
SRA-M Manual lubrication	Id. No.	227456	128181	128199	127034	128035	128471
SRA-Z Central lubrication oil	Id. No.	on request	128182	128200	127033	128034	128470
SRA-OLD Central lubrication oil + air	Id. No.	on request	128183	128201	127035	128036	128472
SRA-F Central grease lubrication	Id. No.	227457	on request	on request	on request	on request	on request

Type SRA

◆ means wearing parts, recommended stock items

Steady Rest size		2	3	3.1	4	5	6
Compact lubrication system for oil pressure lubrication Container 2.7 l, 220 V *,**		088707	088707	088707	088707	088707	088707
Compact lubrication system for oil + air lubrication Container 2.7 l, 220 V *,**		088708	088708	088708	088708	088708	088708
Eccenter fine adjustment compl. at lever arm (2 pieces per Steady Rest)		127237	127240	127240	128474	128584	128585
Inductive limit switch		087926	087926	087926	087926	087926	087926
Swarf guard coolant / air with wiper		128106	124024	124024	125797	125816	128442
Wiper for swarf guard coolant / air	 ◆	128108	124026	124026	126904	126888	128444
Swarf guard (3-pieces)	 ◆	026116	026117	026117	-	-	-
Roller stripper (2-pieces) for middle piece	 ◆	200154	198950	198950	200151	200152	200153
Roller cylindrical design	 ◆	016952	016951	016951	016953	018345	028971
Roller spherical design	 ◆	017658	018433	018433	018443	019545	129825
Roller synthetic material****	 ◆	029451	023443	023443	023672	023650	227357
Roller stripper (2-pieces) for middle piece with roller synthetic material	 ◆	204211	204212	204212	204214	204216	-
Roller carbide	 ◆	129223	129225	129225	220918	222038	on request
Adjustment device 1 set = 3 pieces		-	200178	200178	200179	200179	200179

* When placing an order, please advise voltage.
** On request 110 V available.

*** Stroke control open / closed on request.
**** Attention: Reduced clamping force! Please refer to the clamping force value marked on the roller.