

BH-M

METRIC
SERRATION

High precision power chucks Ø 130 - 450 mm

- Large through hole
- 2, 3 and 4 jaws

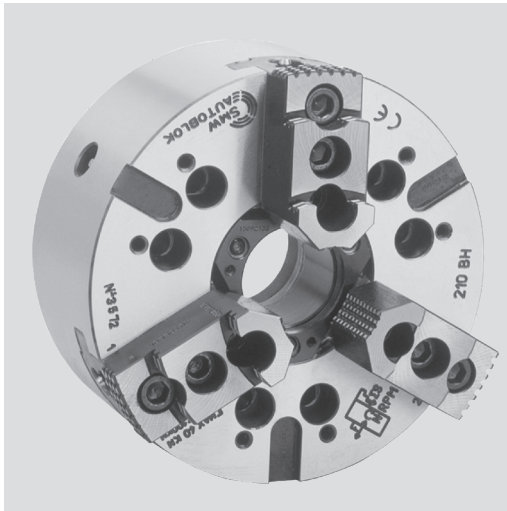

Application/customer benefits

- For open center or partial open center clamping
- Large through-hole

BH-M: Master jaws with METRIC SERRATION (1.5 mm x 60°)
(Suitable for Japanese chucks top jaws)

Technical features

- Gripping force transmission via wedge hook
- Case hardened body to assure greatest precision and long chuck life
- 2 jaw version from diameter 130 to 315
- 3 jaw version available in all diameters
- 4 jaw chuck available starting from diameter 165 mm

Standard equipment

- 2, 3 or 4 jaw chuck
- 1 set T-nuts with bolts
- 1 set soft top jaws
- Mounting bolts

Ordering example

- 2 jaw chuck BH-M 210 / A6
- or
- 3 jaw chuck BH-M 250 / A8

Actual gripping force diagrams

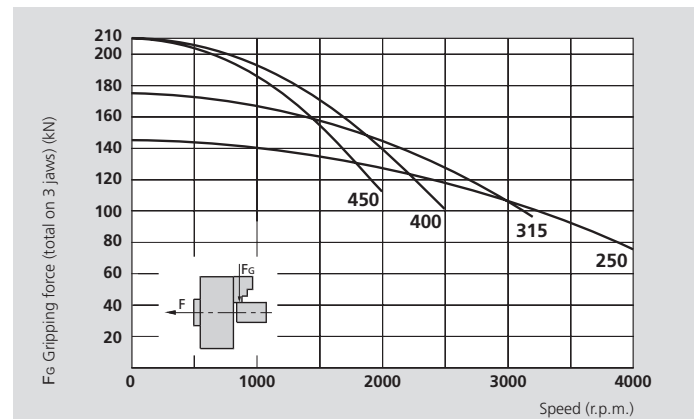
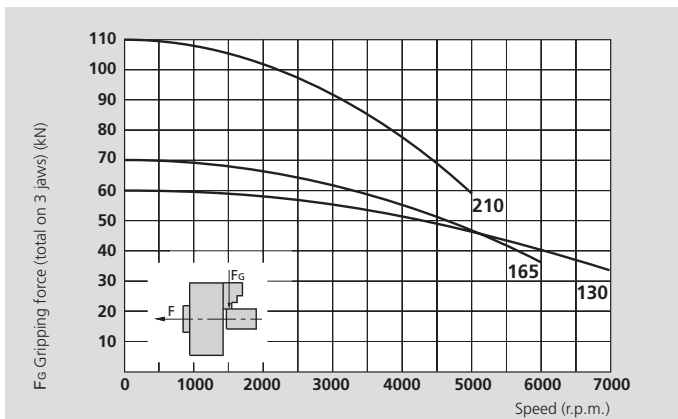

The data in the diagrams refer to 3 jaw chucks, newly maintained according to their service manuals using SMW-AUTOBLOK K05 grease. The static and dynamic gripping forces have been measured using standard soft top jaws, placed in a position not exceeding the outer diameter of the chuck.

△ Safety advice / danger of damage:

When using taller / heavier jaws and / or clamping on a bigger diameter reduce draw pull / rotating speed accordingly.

Technical data

SMW-AUTOBLOK Type		BH-M 130			BH-M 165			BH-M 210			BH-M 250			BH-M 315			BH-M 320			BH-M 400			BH-M 450		
Number of jaws		2	3	2	3	4	2	3	4	2	3	4	2	3	4	3	3	4	3	3	4	3	4		
Through-hole	mm	32			46			52			66			95			103			118			118		
Radial jaw stroke	mm	3.2			3.2			4			5			5			5			6.5			6.5		
Axial piston stroke	mm	15			15			19			24			24			24			31			31		
Max. draw pull*	kN	15	22	17	25	25	25	38	38	34	50	50	40	60	60	60	70	70	70	70	70	70	70		
Max. gripping force*	kN	42	60	48	70	70	72	110	110	98	145	145	115	175	175	175	210	210	210	210	210	210	210		
Max. speed	r.p.m.	7000	7000	6000	6000	5000	5000	5000	4300	4000	4000	3400	3200	3200	2700	3200	2500	2000	2000	2000	1700	1700	1700		
Weight (without top jaws)	kg	5			9.5			19			30			46			52			86			135		
Moment of inertia	kg·m ²	0.012			0.036			0.12			0.27			0.62			0.72			2			3.5		
Recommended actuating cylinders		SIN-S 85 / 100 VNK-T2 70-37			SIN-S 100 VNK-T2 102-46			SIN-S 100 / 125 VNK-T2 130-52			SIN-S 125 / 150 VNK-T2 150-67			SIN-S 125 / 150 VNK-T2 225-95			SIN-S 125 / 150 VNK-T2 250-110			SIN-S 150 / 175 VNK-T2 320-127					

* For internal clamping reduce the draw pull by 30%.



SMW-AUTOBLOK
438

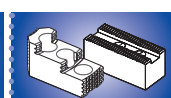

SMW-AUTOBLOK
440

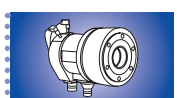

SMW-AUTOBLOK
297

High precision power chucks Ø 130 - 450 mm

BH-M

- Large through hole
- 2, 3 and 4 jaws

METRIC
SERRATION

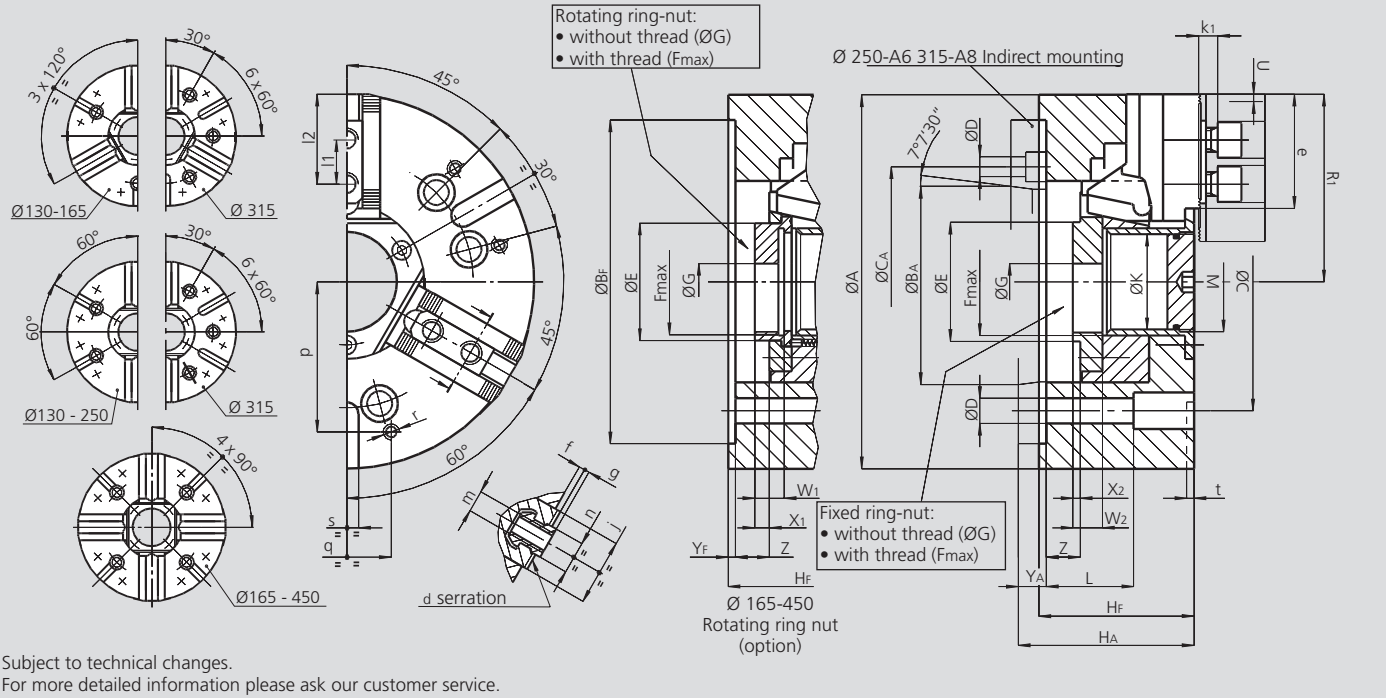

Subject to technical changes.
For more detailed information please ask our customer service.

SMW-AUTOBLOK Type		BH-M 130		BH-M 165		BH-M 210		BH-M 250			BH-M 315			BH-M 320			BH-M 400		BH-M 450	
Mounting		Z115	A4	Z140	A5	Z170	A6	Z220	A6	A8	Z300	A8	A11	Z300	A8	A11	Z300	A11	Z300	A11
A	mm	130		165		210		254			315			325			390		450	
Bf/BA H6	mm	115	63.513	140	82.563	170	106.375	220	106.375	139.719	300	139.719	196.869	300	139.719	196.869	300	196.869	300	196.869
C	mm	82.6		104.8		133.4		171.4	-	171.4	235	-	235	235	-	235	235	-	235	235
CA	mm	-	-	-	-	-	-	-	133.4	-	-	171.4	-	-	171.4	-	-	-	-	-
D	mm	11.5		11.5		13.5		17	13.5	17	21	17	21	21	17	21	21	17	21	21
E	mm	43.5		(*)		67		81			111			119			143		143	
Fmax	mm	M38 x 1.5		(**)		M60 x 2		M75 x 2			M100 x 2			M110 x 2			M130 x 2		M130 x 2	
G	mm	12.5		20		20		25			25			32			70		70	
Hf/HA	mm	67	75	77	87	92	104	105	124	119	111	136	127	111	136	127	128	143	128	143
K	mm	32		46		52		66			95			103			118		118	
L	mm	51		61		66		59			33			33			101		101	
M	mm	M35 x 1.5		M48 x 1.5		M54 x 1.5		M68 x 2			M98 x 2			M106 x 2			M120 x 2		M120 x 2	
Chuck open	R1	mm	66.5	84.5		105.5		127.5			158			162			195		225	
Jaw stroke	U	mm	3.2	3.2		4		5			5			5			6.5		6.5	
	W1/W2	mm	- / 14	18 / 16		20 / 18		33 / 38			33 / 40			23 / 40			33 / 35		33 / 35	
	X1/X2	mm	- / 6	11 / 5		11 / 5		24 / 24			24 / 24			12 / 24			19 / 17		19 / 17	
	Yf/YA	mm	5	13	5	15	5	17	5	19	5	30	21	5	30	21	6	21	6	21
Max. / min.	Z	mm	15 / 0	15 / 0		19 / 0		24 / 0			24 / 0			0 / -24			31 / 0		31 / 0	
Serration	d	mm	1.5 x 60°	1.5 x 60°		1.5 x 60°		1.5 x 60°			1.5 x 60°			1.5 x 60°			1.5 x 60°		1.5 x 60°	
	e	mm	39	49.5		66		77.5			93			93			116.5		146.5	
	f	mm	2	3		3		4			4			4			5		5	
	g	mm	2.5	2.5		2.5		3.5			3.5			3.5			3.5		3.5	
	j	mm	30	33		38		45			45			45			62		62	
	k1	mm	10	10		11		12			12			12			14		14	
	l1	mm	16	20		25		30			30			30			34		34	
Max. / min.	l2	mm	32 / 23	41 / 24		56 / 33		62 / 43			78 / 43			78 / 43			90 / 49		120 / 49	
	m	mm	M8	M10		M12		M12			M16			M16			M20		M20	
	n h8	mm	12	12		14		16			21			21			22		22	
	p	mm	52	65		80		102			100			100			150		150	
	q	mm	30	36		45		60			60			60			80		80	
	r	mm	M6	M8		M8		M10			M10			M10			M12		M12	
	s H12	mm	12	16		16		16			20			20			20		20	
	t	mm	5	5		5		5			5			5			5		5	

* E fixed ring nut Ø 60
E rotating ring nut Ø 56
** F_{max} fixed ring nut M55 x 2
F_{max} rotating ring nut M50 x 1.5